

AERONAUTICAL ENGINEERING SERIES

GROUND ENGINEERS

THE RIGGING
MAINTENANCE AND
INSPECTION OF AIRCRAFT
(“A” LICENCE)

W. J. C. SPELLER

5/- NET

PITMAN

~~Howard. Sgt.~~

R.A.F. Seamerabad.

Wright. ~~Sgt.~~

~~No 2 Squadron~~

R.A.F.

Seamerabad

9th Highland Highlanders.

Richwood

Uckfield

Sussex

AERONAUTICAL ENGINEERING SERIES

GROUND ENGINEERS

THE RIGGING
MAINTENANCE AND
INSPECTION OF AIRCRAFT
(“A” LICENCE)

BY

W. J. C. SPELLER



The Air Ministry, whilst accepting no responsibility for the contents of this book, recognizes it as a textbook that should prove to be of value to intending applicants for Ground Engineers' licences

LONDON

SIR ISAAC PITMAN & SONS, LTD.

1935

AGENTS
THE

W. J. C. SPELLER

First Edition. 1934
Reprinted. 1935
Reprinted. 1935

SIR ISAAC PITMAN & SONS, LTD.
PITMAN HOUSE, PARKER STREET, KINGSWAY, LONDON, W.C.2
THE PITMAN PRESS, BATH
PITMAN HOUSE, LITTLE COLLINS STREET, MELBOURNE
ASSOCIATED COMPANIES
PITMAN PUBLISHING CORPORATION
2 WEST 45TH STREET, NEW YORK
SIR ISAAC PITMAN & SONS (CANADA), LTD.
(INCORPORATING THE COMMERCIAL TEXT BOOK COMPANY)
PITMAN HOUSE, 381-383 CHURCH STREET, TORONTO

FOREWORD

BY CAPTAIN A. E. STEELE

“ANY such aircraft flying for public service shall not fly unless it has within twenty-four hours been inspected and certified as safe for flight . . .”

“An inspection under this paragraph shall be carried out by a competent person licensed for the purposes of this Schedule . . . etc. . . .”

The above extracts from the Air Navigation (Consolidation) Order, 1923, will serve as an introduction to this foreword dealing with the examination of applicants for Ground Engineers' licences valid in Category “A.”

Having made up his mind to become licensed as a person competent to inspect and certify an aeroplane before flight, the prospective ground engineer should communicate with the Secretary (D.C.A.) Air Ministry, asking to be supplied with a form of application.

In due course he will be supplied with a copy of C.A. Form 2.B. together with a copy of A.M. Pamphlet 34. The latter is entitled “Instructions to Applicants for Ground Engineers' Licences and Syllabus of Examinations.” It informs the applicant that he must provide himself with copies of the Air Navigation (Consolidation) Order, 1923, and the Air Navigation Directions, and clearly indicates that these publications are to be studied and digested before he presents himself for examination. It recommends that he obtain a copy of the Airworthiness Handbook for Civil Aircraft (A.P. 1208).

From the foregoing remarks it will be appreciated that the first thing to be done by the aspirant for a ground engineers' licence is to become acquainted with the statutory rules and regulations which govern Civil aviation. The publications with which he is instructed by A.M. pamphlet 34 to provide himself, detail the duties and qualifications of ground engineers. They are obtainable from H.M. Stationery Office in London, Edinburgh, Manchester, Cardiff, and Belfast, or through any bookseller.

From a perusal of these publications he will learn the qualifications which are necessary. Briefly stated, he should have attained the age of twenty-one years, and he must have had such practical experience as in the opinion of the Secretary of State will enable him to perform the duties for which the licence is required. A.M. Pamphlet 34 details the syllabus of the examination for Category “A,” and the applicant should be able to appreciate that considerable practical experience of

rigging, maintenance, and inspection of aircraft must be obtained to enable him to pass the examination.

When the applicant has completed the application form, he will forward it as directed thereon, accompanied by the appropriate fees, to the Secretary (D.C.A.) Air Ministry.

If, from a perusal of the particulars given on the application form, it is decided that the applicant can be accepted, he will be requested to present himself for examination either in London or at some more convenient centre in the provinces.

On his appearance before the examination board the candidate will first be questioned with a view to testing his knowledge of the regulations and of the duties, as governed by the regulations, for which he requires to be licensed.

The possession of the ground engineer's licence valid in Category "A" authorizes the holder to certify that an aircraft of a type or types stated on his licence has been properly inspected and is in a satisfactory condition for flight.

To enable him to do this he must be in a position to know that the aircraft which he is about to certify has been properly assembled and correctly rigged, that it has been properly maintained and that any repairs or essential modifications (the incorporation of which it is pointed out is outside the scope of a Category "A" licence) have been carried out in a satisfactory manner as duly recorded and certified by a ground engineer licensed to do so.

If any new parts or components have been fitted, he must be able to produce evidence, documentary or otherwise, to show that such parts or components are true to the type and made correctly in accordance with specifications and drawings. For this purpose he should have some knowledge of the system whereby certain firms and manufacturers have received Air Ministry approval of their inspection organizations, and are thus authorized to issue "release notes" covering goods supplied by them and certifying their compliance with the relevant specifications and drawings.

He must ensure that any modifications, the need for which has been notified by means of Notices to Aircraft Owners and Ground Engineers as applicable, have been correctly embodied. Conversely, he must be satisfied that no unauthorized modification has been incorporated.

It will be found that the regulations provide detailed information concerning the procedure to be followed with regard to modifications to civil aircraft.

He must satisfy himself that the aircraft log book is properly maintained and that it provides a connected history of the life of the aircraft. Entries should be made to show how the aircraft has been used, the amount of flying done, and any repairs, replacements,

modifications, or overhauls carried out, together with references to release notes, notices to Aircraft Owners and Ground Engineers, etc., which may be applicable. Before a ground engineer can finally certify that a particular aircraft is in all respects in a satisfactory condition for flight, he must not only be satisfied that it is correctly assembled and rigged, he must also ensure that its equipment, in the light of the flight which it is about to make, is in accordance with the regulations. Other features must be taken into consideration, the Classification of the Aircraft as shown by the Certificate of Airworthiness, the number of seats, the type of accommodation, i.e. open cockpit or enclosed cabin, the type of aircraft, i.e. whether landplane, seaplane, or amphibian, all have a bearing on the nature of the equipment to be carried, and by the term "equipment" is meant not instruments only, but such items as safety belts, fire extinguishers, etc.

The Air Navigation Directions provide full information in respect of the equipment to be carried in varying circumstances.

Having finally satisfied himself that the aircraft is in all respects in a satisfactory condition in accordance with the regulations, he is in a position to complete his certificate. The questions thereupon arise—what form of wording is he to use for his certificate? How many copies are to be made out? How are they to be disposed of? How long are they valid? How long must they be retained?

The Ground Engineer must know the answers to all these questions. The Air Navigation (Consolidation) Order, 1923, and the Air Navigation Directions provide the information, but it is impracticable to expect the Ground Engineer to be in a position of having to refer to these publications at every turn. He has no right to expect to have a licence issued to him unless he can show that he has made himself familiar with the regulations, any more than he can expect to have a licence if he cannot show that he can rig or maintain a given aircraft.

He is taking on a responsible job and he must be able to deal with it in all its aspects.

He must understand that the regulations to which he must conform, and with which he must therefore be conversant, have not been drawn up casually or in any haphazard manner to meet the needs of this country alone. He will find that they have been produced as a result of considerable thought and after a great deal of discussion between representatives of most of the nationalities of the world. Once these facts have been appreciated it is hoped that the aspirant for a ground engineer's licence will realize why so much importance is attached to a sound knowledge of the regulations which govern Civil Aviation.

PREFACE

AN "A" licensee is required to be conversant with the Air Navigation Directions and Statutory Rules and Orders so far as they are applicable to his duties. He is required to have had sufficient practical experience in aircraft maintenance and/or construction and to have a knowledge of all the subjects dealt with in Chapters I and II, and 16 and 17 of Chapter IV herein, these being the minimum requirements. The whole subjects of Chapters III and/or V and/or either or both 18 and 19 (which is usually divided—ashore or afloat) of Chapter IV may be included in, or may form an extension of a Category "A" licence. The subjects (with the exception of the electrical section, which is also a part of Category "X") individually may be made an extension of the whole or any one of the Ground Engineers' licences, Categories "A," "B," "C," "D," and "X."

"A" licences are usually granted in respect of specific kinds and types of aircraft. In this book the subjects have been fully treated; indeed, in many cases they will be found more comprehensive than the requirements of an examining board demand.

This book will be found of service to Air Forces, to the staffs and students of Schools, Colleges, Universities, and Training Institutions; personnel in workshops, at aerodromes and seaplane bases; juniors and apprentices and all who desire a sound and thorough knowledge and understanding of everything appertaining to the practical maintenance of heavier-than-air craft.

The author is deeply indebted to Mr. T. C. L. Westbrook, General Manager of the Supermarine Aviation Works (Vickers), Ltd., whose help in the preparation of the text and many of the illustrations has been invaluable.

His thanks are also due to Mr. H. H. Cadman for many helpful suggestions and revision of the proofs.

Acknowledgment has also to be made of the courtesy and assistance received from Vickers (Aviation), Ltd., Mr. T. S. Duncan, Messrs. Reid and Sigrist, and Bendix, Ltd., in supplying information regarding their products.

CONTENTS

	PAGE
FOREWORD	v
PREFACE	ix

CHAPTER I

ASSEMBLY AND RIGGING, AND THE CORRECTION OF FAULTS

1. ASSEMBLY OF AIRCRAFT STRUCTURE; RIGGING ADJUSTMENT AND CHECK	1
2. CONTROLS: ADJUSTMENT AND CHECK	5
3. CORRECTION OF FAULTS EXPERIENCED IN FLIGHT	8

CHAPTER II

DEFECTS AND DETERIORATION IN MATERIALS, AND METHODS OF EFFECTING MINOR REPAIRS AND REPLACEMENTS

4. TIMBER: DEFECTS AND DETERIORATION	10
5. METALS: DEFECTS AND DETERIORATION	12
6. OTHER MATERIALS	16
7. AIRSCREWS	21
8. CONTROL MECHANISM: DEFECTS AND DETERIORATION	23
9. INSPECTION AFTER A BAD LANDING	24
10. MISCELLANEOUS GEAR	25
11. GENERAL MAINTENANCE AND MINOR REPAIRS	38

CHAPTER III

SEAPLANES AND FLYING BOATS

12. ORDER OF ERECTION (FLYING BOATS)	42
13. RIGGING	42
14. GENERAL MAINTENANCE AND MINOR REPAIRS OF HULLS AND/OR FLOATS	48
15. MARINE EQUIPMENT: DESCRIPTION AND MAINTENANCE	52

CHAPTER IV

INSTRUMENTS: METHODS OF INSPECTING AND TESTING THE INSTALLATION

16. AIR SPEED INDICATORS	55
17. ALTIMETER	59
18. TURN INDICATOR	61
19. COMPASS INSTALLATION IN AIRCRAFT, AND ADJUSTMENT	63

CHAPTER V

GENERAL SERVICE ELECTRICAL INSTALLATION
INCLUDING CONTINUITY AND INSULATION TESTS

	PAGE
20. THE GENERATOR	72
21. ACCUMULATORS	83
22. LOW TENSION INSULATED CABLES	87
23. GENERAL ELECTRICAL PARTS, COMPONENTS, AND ACCESSORIES	96

APPENDICES

I. SPECIMEN CERTIFICATE OF SAFETY FOR FLIGHT	103
II. SPECIMEN RELEASE NOTE	105
III. LIST OF METALS AND ALLOYS	107
IV. GLOSSARY OF AERONAUTICAL TERMS	111
V. THE LAW RELATING TO CIVIL AVIATION	117

THE RIGGING MAINTENANCE AND INSPECTION OF AIRCRAFT

By W. J. C SPELLER

CHAPTER I

1. ASSEMBLY OF AIRCRAFT STRUCTURE AND RIGGING ADJUSTMENT AND CHECK

Fuselage Rigging Adjustment and Check

THE first component in the assembly of a landplane is the fuselage, and it is assumed here that this component is correctly assembled and truly

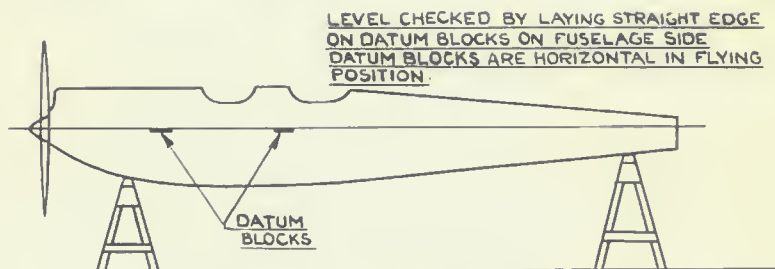

FIG. 1. RIGGING POSITION

rigged. The fuselage should be placed on trestles and arranged longitudinally and laterally approximately level, allowing sufficient height to enable the undercarriage to be attached. The supporting trestles must be placed under the jacking blocks, which are usually situated near the front undercarriage struts, and at the rear of the fuselage near the tail skid. The fuselage when correctly positioned for assembly of the superstructure is said to be in the "rigging position" (see Fig. 1).

The "rigging position" is indicated in the rigging notes contained in the maker's handbook, or on the rigging diagram supplied for each type of aircraft. Datum lines or fixed levelling blocks (see Figs. 1 and 2) are now provided on all modern aircraft, and they enable the rigger easily to set the fuselage into correct position both longitudinally and laterally. When level the fuselage should be securely anchored.

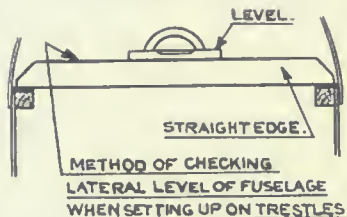

FIG. 2. FIXED LEVELLING BLOCKS

Undercarriage

Now attach the undercarriage, which is usually rigged so as to be symmetrical about the centre line of the fuselage both in front and plan view. Undercarriages vary in design and construction, for small aircraft they usually consist of two side struts forming a "V" each side, axles, shock-absorbing devices, and cross bracings of flexible cable or streamline wire. For truing up the undercarriage the cross bracings should be adjusted to be equal in length; check this by the use of trammels, next drop plumb lines from the longerons on to the axle tube, and measure to the inside of the wheel flanges (see Fig. 3).

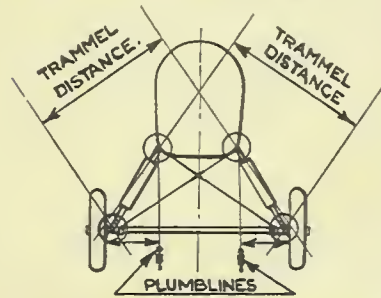

FIG. 3. TRUING UP UNDERCARRIAGE

When equal in length on each side the axle is central. Another method of checking can be made (1) from the outside of the wheel hub flange to some point in the centre of the fuselage between the undercarriage and

sternpost, and (2) from the axle cap to some important fitting on the underside of the lower planes.

Centre Section

This is usually the next component to be erected, and if the struts are wooden members they must be carefully fitted and "bedded" in the strut sockets.

This unit can be roughly assembled on the ground and lifted into position. The loose ends of the struts are next attached to their respective fittings on the fuselage, and the ends of the bracing wires and struts are connected up.

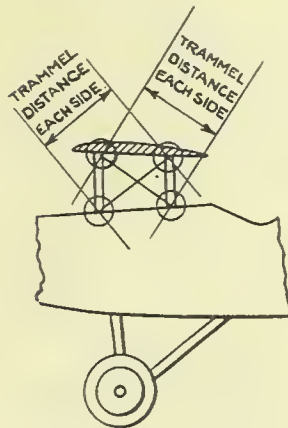

FIG. 4. TRUING UP TOP CENTRE PLANE

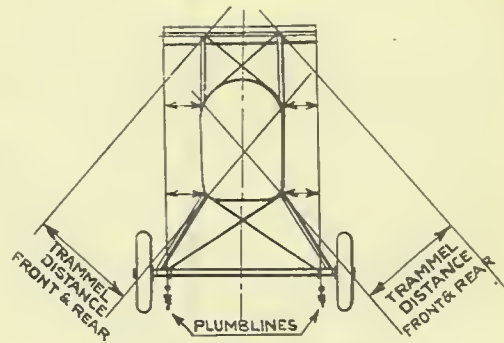

FIG. 5. TRUING UP TOP CENTRE PLANE

Truing Up the Centre Section

To true up the centre section, trammel the front, side, and rear diagonals (see Figs. 4 and 5) until the leading edge is horizontal and symmetrical

about the vertical centre line of the aeroplane, and is correctly (if applicable) staggered relative to the bottom plane position. The bracing wires are to brace the structure correctly and must not be used otherwise to pull a plane into its correct position or incidence.

Checking the Centre Section After Rigging

Drop plumb lines from the spar wing attachment fittings, front and rear, right and left sides, and measure to the fuselage. The measurement should be the same each side. To check the stagger, drop plumb lines over the leading edge of the top centre section and measure to the leading edge of the stub wing, or from the existing line from the top wing attachment fittings, measure to the lower wing attachment fittings on the fuselage. These dimensions should be equal on both sides and correct with the requirement laid down in the aircraft rigging diagram.

Attaching Main Planes (Medium biplane two-bay types).

The lower plane should be placed in a position with its chord vertical, care being taken not to damage the fabric or protective coating on the leading edge. Next fit the interplane struts, taking special precautions, where the diameters and lengths of the struts vary, that they are in their correct positions. The upper main plane should then be positioned to the lower plane so that the interplane struts may be attached. The bracing wires should then be joined to their respective fork ends and great care taken to see that these attachments are in their correct position. Remember that the flying wires (which may be duplicated) are usually of a heavier gauge than the landing wires. Enter the wires carefully into the fork ends and commence turning, noting that the same number of threads are engaged at each end.

Having now boxed up the planes into a fairly rigid structure, lift into position, connect up the spar attachments, and then join up the bracing wires for the inner bay, first the inner landing wires from the top centre section to the bottom of the inner pair of interplane struts. Adopt the same method for each side to complete the assembly of the main planes. For method of mounting the main planes of seaplanes having a single set of struts, and for the larger multi-bay machines, see Chapter IV, "Rigging and Assembly of Flying Boats."

Truing Up the Main Planes

In most cases the aircraft manufacturers provide levelling, incidence, and dihedral boards (see Figs. 6 and 7), to enable a rapid and accurate

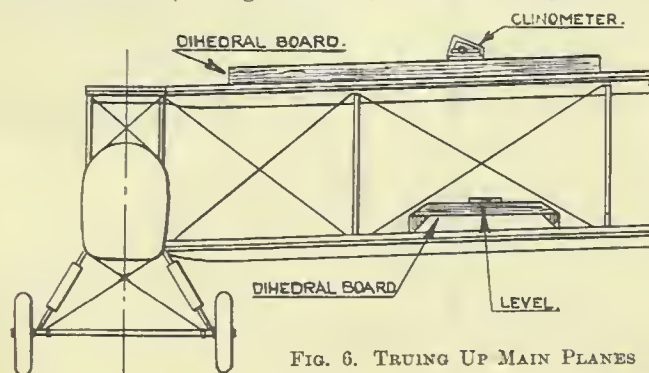

FIG. 6. TRUING UP MAIN PLANES

check to be made of the incidence and dihedral angles. If these special boards are not available, angles should be checked by using a straight edge and clinometer (also shown in Figs. 6 and 7).

The dihedral angle of the main plane is fixed by the adjustment of the front landing wires, and is checked by means of dihedral board or straight edge and clinometer over the front spar.

The stagger is adjusted by the cross bracing between the front and rear interplane struts, and is checked by measuring horizontally the dis-

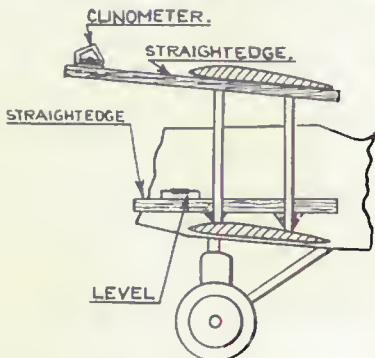

FIG. 7. TRUING UP MAIN PLANES

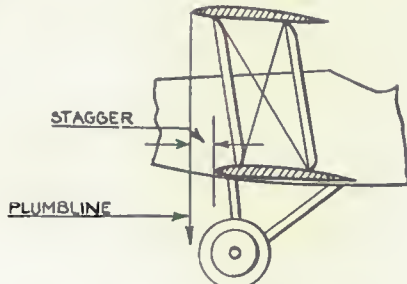

FIG. 8. MEASURING STAGGER

tauce of a plumb line dropped from the leading edge of the upper main plane to the leading edge of the lower main plane (see Fig. 8).

The incidence of the main planes is adjusted chiefly by means of the rear landing wires, in conjunction with the incidence bracing between the front and rear interplane struts. The incidence is checked by using the special board with a level, or by means of a clinometer resting in a straight edge which is held up under the main plane and along one of the ribs (see Fig. 6).

When the dihedral and incidence angles, on each side, and the stagger are all correct, the planes have to be checked to see that they are symmetrical with the fuselage by measuring from points at the upper and lower outer front strut fitting to the stern post and the centre of the airscrew shaft.

Truing Up the Tail Unit

The tail plane is laterally horizontal and is symmetrical about the centre line of the fuselage. This component is checked transversely with a straight-edge and spirit level (see Fig. 9), if the spars are tapered packing blocks are necessary. The incidence must be checked by using a special board and a clinometer (see Fig. 10), and if the aircraft is fitted with an adjustable tail plane the incidence in the upper and lower positions must also be checked.

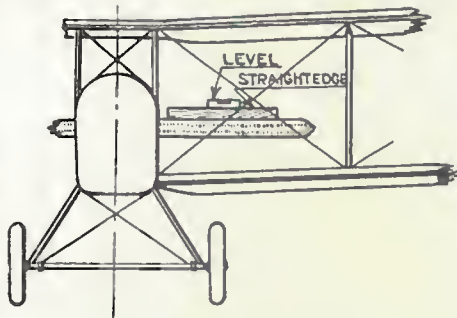

FIG. 9. TRUING UP TAIL UNIT

The rudder is checked vertically by dropping a plumb line over each side. Pack out against the top rib and measure between the line and the lower trailing edge of the rudder. The longitudinal centre line of the fin may coincide with the centre line of the aircraft, or be offset to right or left to give slight rudder effect. This must be checked to the dimension or angle given in the maker's handbook.



FIG. 10. MEASURING TAIL PLANE INCIDENCE

2. CONTROLS: ADJUSTMENT AND CHECK

General

The safety of an aircraft in flight is directly dependent upon the correct and adequate functioning of its flying controls. Every precaution must, therefore, be taken by the inspector to ensure the correctness of each element forming part of such a system, in addition to ensuring the adequacy of its installation, functioning, and range of operation. As meticulous care is essential and no individual infallible, the duplication of final inspection called for hereunder must not, in any circumstance, be departed from.

Control Assembly

The inspection of all aircraft controls must be duplicated, first as an operation during assembly of the aircraft, and, secondly, as part of the inspection immediately preceding flight. These two stages of inspection may not, in any circumstances, be carried out by the same individual.

IMPORTANT. It must be clearly realized that such duplicate inspection must be carried out invariably after all adjustments have been made. Not only has the functioning to be checked, but each separate control must be followed through from end to end and a careful examination made of all joints, junctions, and locking devices. If dismantling or any further adjustment of the controls is carried out thereafter, the duplicate inspection must be repeated.

Flying Controls

An aeroplane is controlled by means of the following control surfaces—Ailerons, Elevators, Rudders.

The *Ailerons* control the aeroplane laterally, or, in other words, they tend to make the aeroplane rotate round the axis of the fuselage (or hull in the case of a flying boat).

If the control stick is moved to the right or the pilot's control wheel turned to the right, the right ailerons must come *up*, and correspondingly the left ailerons go *down*.

The effect of this is to decrease the lift on the right planes and to increase that on the left planes, with the result that the machine banks to the right. Similarly, if the stick is pushed or the wheel turned to the left, the machine banks to the left.

The Elevators control the fore and aft movements of the machine, that is, they move the machine in a path at right angles to the planes. If the machine is flying level, and the pilot's control column is pulled back, the elevators are raised, the tail drops, and the nose rises. If the pilot's control column is pushed forward, the elevators go down, the tail rises, and the nose drops.

The Rudder (or rudders) swings the machine along a path parallel with that of the main planes. If the right rudder-bar or rudder pedal is pressed forward, the rudder moves to the right, the tail swings to the left, and the nose of the machine swings to the right. If the left rudder-bar or rudder pedal is pressed forward, the rudder moves to the left, the tail swings to the right and the nose of the machine swings to the left.

Variable Tail Plane

The tail incidence is usually operated by means of a hand wheel or sometimes a lever in the pilot's cockpit, and to increase the incidence of the tail plane the top rim of the hand wheel is pushed forward, the incidence is decreased by winding the wheel backwards. The directional control of this unit is similar to the elevator control.

Flying Controls—Adjustment and Check

After assembling the aerofoils and coupling up the controls, adjustments should be made so that the cables and other parts are fairly taut, but work without undue stiffness. All control cables, chains, rods, and levers should be carefully inspected to ascertain that these parts are in good condition and bear evidence of prior approval, and that all unions, joints, and attachments whatsoever throughout the entire system are properly and effectively locked. The flying control systems of modern aircraft are usually operated by means of extra flexible stranded cable of 7×19 construction, there being seven strands each containing nineteen wires.

It is often necessary to fit new cables, and care must be taken that the splicing is in accordance with standard requirements. When a splice is made round a thimble the cable must be gripped tightly by means of a temporary serving; $4\frac{1}{2}$ tucks are required, the splices are whipped with waxed thread. On marine aircraft the whipping is carried further up the splice than on landplanes to prevent ingress of sea water and deter corrosion. The waxed cord must be removed from time to time to allow thorough inspection of the splice. After splicing, all cables must be stretched by applying a tensile load of 50 per cent of the breaking load of the cable.

When roller chains form part of the flying control system they must be of an approved type, and should it become necessary to replace any parts or attachment fittings, the complete chain unit must be proof loaded to one-third of the ultimate load specified by the aircraft manufacturers.

AILERONS

In order to allow for the stretch of the cables when under load, ailerons are sometimes given an initial droop, the trailing edge of the aileron being set below the trailing edge of the wing. This droop is the measured difference between the trailing edge line of the wing and the trailing edge line of the aileron. Care must be taken to ensure that the control column is central when checking the amount of aileron droop; similarly the control column must always be central when adjusting the ailerons (the column is not always fore-and-aft vertical, for on some types of aircraft it is set forward of the vertical position, while on others it may be set aft).

The maker's handbook or control system diagram must be carefully studied when making adjustments; this matter is very important and applies to all flying controls. Limits of travels must be checked, and it is advisable to record the measurements in a simple form (see Fig. 11). Particular care is necessary when the balanced or Frise type ailerons are fitted, to ensure that the maximum travel is not exceeded. All control pulleys must be in proper alignment. Guards must be quite clear but must be close enough to prevent the cables riding off the pulleys or the chains off the sprockets. Chains and sprocket teeth, and sprocket and pulley bearings, must be kept clean and lubricated. The control wires or

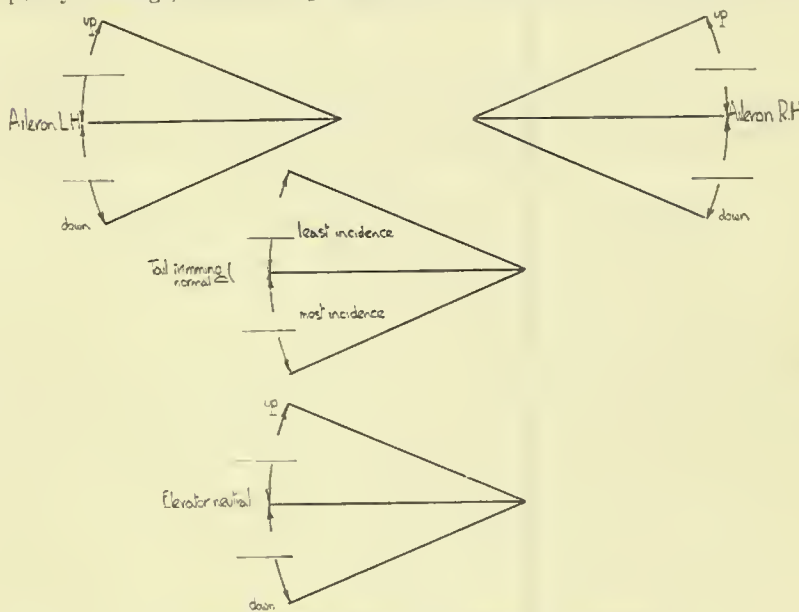

FIG. 11. MOVEMENTS OF CONTROL SURFACES

cables must not be unduly slack; at the same time they should not be over-tight, but should work smoothly throughout the whole of their run. It is advisable during the course of inspection to have the control column and the rudder bar held while an attempt is made to move the various control surfaces, due care being exercised as to the degree of load imposed and as to how and where the individual surfaces are grasped during this test.

ELEVATORS

When checking the elevators the control column must be central transversely; it is not, however, always required to be vertical as viewed in side elevation, and this fact must be carefully noted by the rigger, who must observe the instructions on the maker's rigging diagram. It is essential that the tail plane incidence be adjusted to normal position and the elevators set in a continuous line with the tail plane. After correct tensioning of the control wires or cables the elevator must be tested for functioning at all tail plane settings, and at the same time the rudders should be operated to make certain that they do not foul the elevators. The control

column's forward stop must be set to allow the correct amount of downward travel, but care must be taken to ensure that corners of the elevator spars do not come in contact with the tail plane rear spar. The travels of the elevator must be strictly in accordance with the design requirements.

RUDDER

When adjusting the rudder controls, care must be taken that the rudder bar or rudder pedals are set at right angles to the fore and aft line of the aircraft, the rudder being central and vertical. The rudder stops must be positioned to allow the correct travel. The rudder controls should just be taut and should work smoothly throughout their run.

TAIL TRIMMING GEAR

It is very important to check the normal incidence, and at the same time to make certain that the indicator position synchronizes. This should again be checked at the maximum upward and downward positions.

The run of controls must be carefully inspected and directional functioning tested after any adjustments have been carried out.

3. CORRECTION OF FAULTS EXPERIENCED IN FLIGHT

- (i) Tendency to fly one wing low.
- (ii) When an aircraft does not fly straight.
- (iii) Nose or tail heavy.

(i) Tendency to Fly One Wing Low

If an aircraft is reported by the pilot to be flying right wing low, it may be due to the following—

(a) Incidence on the left wing greater than on the right wing, thus increasing the lift on the left wing.

(b) Ailerons warped or out of alignment when the control column is central.

(c) Dihedral greater on one side than the other.

(d) The wings becoming distorted.

(e) Unequal loading.

(f) Tail plane out of alignment laterally.

CHECK (a)

By placing the aircraft in rigging position and testing the angle of incidence on each wing. Should it be found that the angle of incidence is less than it should be on the right wing, adjust it to the correct setting. If the incidence is more than it should be on the left wing, decrease the same to maker's rigging diagram requirements. It may happen that the wing incidence is correct in which case—

CHECK (b)

If the ailerons are not in trim due, say, to stretch or slackness of cable, adjust to standard for type. If warped, aileron should be changed, or droop adjusted to compensate. Take care that this does not cause drag and result in giving the aircraft turning tendency.

CHECK (c)

The dihedral angles on each wing should be checked and adjusted if necessary.

CHECK (d)

Try with straight-edge wherever possible in way of spars, and also compare incidence readings on numerous similar places on each plane.

Distortion may be due to overtight bracings; if it persists when wires are entirely slacked off, wing must be removed and opened up for investigation.

CHECK (e)

This may be due, say, to unequal fuel consumption, or, in a seaplane, to water in a float: the remedy in either example being self-evident.

CHECK (f) and, if out of alignment, correct.

A test flight should be carried out when everything has been corrected: should the pilot still report that the aircraft is flying right wing low, give more incidence on the right wing and slightly decrease the incidence on the left wing (both, of course, towards the tips known respectively as "wash-in" and "wash-out.")

(ii) When an Aircraft Does Not Fly Straight

This may be due to the fin not being in the correct position, which gives the effect of slight rudder. Rubber cord, or a spring in the rudder control system, is sometimes fitted to counteract this defect, and if such or any other device is fitted it must be carefully inspected and treated as part of the flying control system. It must be understood that no alterations beyond the normal adjustment of such a loading device as mentioned can be authorized to correct this error, unless the Ground Engineer is notified through official channels.

An aircraft carrying rudder gives the impression of flying one wing low. When an aircraft is reported to be flying one wing low and carrying rudder at the same time it is advisable to counteract the turning tendency by adjustments and test flight before giving "wash-in" or "wash-out" to the planes, provided the aircraft was flying in a normal manner previously. Alternatively, holding one wing up will cause drag in that side and cause the aircraft to turn in that direction.

The degree of offset (to counteract torque) of the engine may be incorrect; an engine licensee must be called to correct any such error. In the case of a pusher aircraft having the airscrew close to the fin, the fitting of a new airscrew of different pitch having more or less r.p.m. than the previous one and causing the slipstream swirl to impinge on a different point on the fin may upset the directional stability; such a condition may be counteracted in the manner mentioned above.

(iii) Nose or Tail Heavy

This defect may be caused through—

- (a) Incorrect stagger.
- (b) Incorrect incidence of tail plane.
- (c) Incorrect incidence of main planes (although both sides may be equal).
- (d) Incorrect loading of the aircraft.
- (e) Distortion of fuselage or hull.
- (f) Water in the hull, main floats, or tail plane. (Seaplanes.)

Place the aircraft in rigging position, check and correct where necessary (a) (b), (c), and (e). Regarding fault (d) great care must always be taken when loading an aircraft that the C.G. limits are strictly observed.

(f) Drain all floats, tail plane and elevators and see that the eyelets in the two latter are clear.

Where fixed servo flaps are fitted to control surfaces, flying errors may often be corrected by "setting" such flaps *away* from the direction of the dip or turn.

CHAPTER II

4. TIMBER—DEFECTS AND DETERIORATION

WOOD is not used to a great extent on modern aircraft; there are still, however, numbers of light aircraft of composite construction, i.e. wood, fabric, and metal. Structures made of timber are very much affected by extremes of atmospheric conditions. All timber used in aircraft construction is very carefully selected, therefore the defects dealt with below are those which develop after the aircraft has been in service.

Timbers commonly used are silver spruce, ash, walnut, mahogany, and plywood. Silver spruce is the most widely used for aircraft construction. Ash is used for engine bearers and fuselage struts, tail struts, etc., and walnut for airscrews and packing blocks. Mahogany is used for the construction of hulls, floats, and airscrews. Plywood, usually birch, is used for fairings, sides of box spars, walk-ways, rib webs, covering of the leading edge of wings, tail units, and on flying boats for top surfaces of wings and centre sections.

Defects

The most serious defects are: (a) brittleness, (b) compression shakes, (c) shrinkage, (d) oil soakage, (e) water soakage, (f) crushing, (g) (plywood) sagging, and ply separation.

Brittleness

Wooden parts become brittle due to the moisture drying out and shrinkage occurring. It is very difficult to detect this serious defect without destroying the part suspected, but if the shrinking is such as to cause slackness of metal fittings it should be reported to the makers or to a Ground Engineer licensed in Category "B" for guidance.

Compression Shakes

Wooden aircraft structures can absorb vibrations and minor shocks without serious damage, but under large shock loads such as heavy one-wheel, tail, or wing tip landings, compression shakes may be found in the longerons and main wing spars. Only the most careful inspection will reveal the presence of this kind of shake, and an indication is often given by the fracture having caused the varnish to crack across the fibres of the wooden member (see Fig. 12).

Shrinkage

Shrinkage in timber occurs if the conditions are too dry, resulting in the breaking down of glued joints and slackness of metal fittings. This may obtain particularly on component parts that have been stored for any considerable period.

Oil Soakage

Engine bearers and other timber parts near to the engines and oil tank must be carefully cleaned, and protective coatings should be maintained to prevent the wood from becoming oil soaked. It may be necessary from

time to time to scrape parts lightly and re-varnish; if the oil has soaked below the surface the strength of affected parts will be impaired.

Water Soakage

When fitting new struts, etc., great care must be taken that, after shaping, ends are treated with an approved protective coating of varnish or paint, otherwise the timber may become water-soaked and develop blue-stain, a defect to which silver spruce is very subject; this is sometimes on the surface only, but in its more advanced stage it penetrates very deeply and is the first stage of rot.

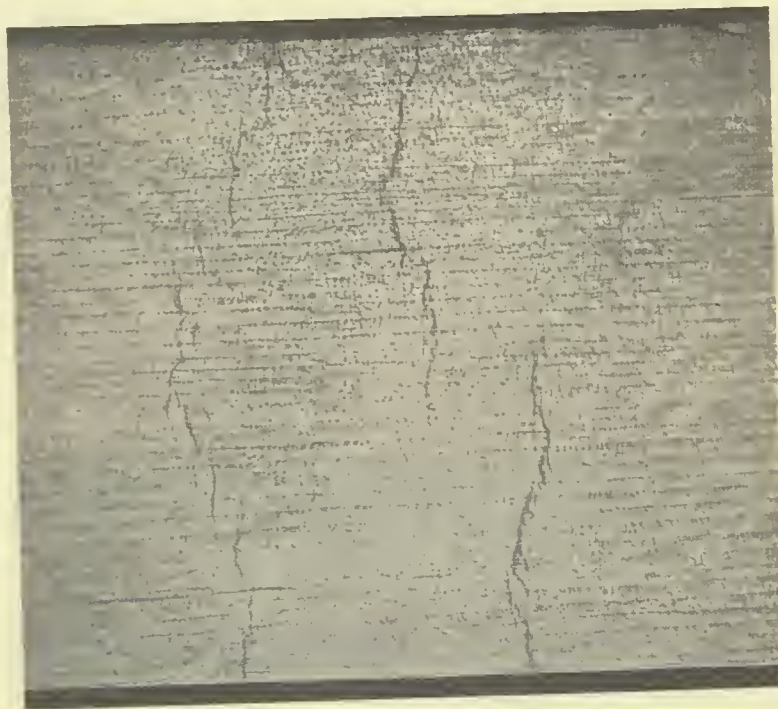

FIG. 12. TIMBER COMPRESSION SHAKE

Crushing

Wood parts are crushed by the overtightening of metal fittings and incorrect tensioning of bracing wires. The most serious form of crushing is usually caused through bad landings, and this can only be discovered by means of careful and systematic inspection.

Sagging and Ply Separation

The individual veneers of plywood sometimes become non-adherent. Plywood often sags; the timber itself sometimes loses its moisture and becomes brittle. Plywood parts should always be well protected, particularly around the edges, with liberal coatings of paint, enamel, varnish, marine glue, or other suitable protective material.

5. METALS: DEFECTS AND DETERIORATION

All metallic materials used for aeroplane construction are carefully listed and inspected, and also suitably protected against corrosion before the parts are finally passed out from the makers. Most of the subsequent defects and deteriorations can be said to be due to corrosion. In light alloys corrosion is usually in two forms -

- (a) External.
- (b) Inter-crystalline.

(a) External Corrosion

As very light sections of materials are used in aircraft construction, corrosion will soon weaken the structure, and cause failure. Careful and systematic inspection must be carried out in order to arrest corrosion in its early stages. Fortunately most instances of corrosion are on the surface, and although this kind of corrosion is not very dangerous, being visible by the formation of a white powder (aluminium oxide), it may be liable to form pits and/or cavities. If this pitting is not very deep it can be removed carefully by using a soft scraper and stiff brush; the parts should then be immediately treated with lanoline or protective coatings similar to those used on other parts of the aircraft. If it is found after removing corrosion on fittings that the corrosion is deep enough to cause weakness the fitting must be rejected. In the case of steel plates the bad place may be removed and replaced by a suitable patch.

(b) Inter-crystalline Corrosion

Corrosion in this form is extremely dangerous, there being no white powder as in the case of surface corrosion. The only signs are surface



FIG. 13. DURALUMIN—INTERCRYSTALLINE CORROSION

cracks, which are sometimes very small and can only be detected with the most careful examination (see Fig. 13).

These inter-crystalline corrosion cracks do not frequently occur, but should be watched for, and however fine or small the crack the part must be immediately rejected. This form of corrosion attacks the crystal boundaries inside the metal, making it weak and brittle. Alclad need not be rejected until about 75 per cent of the aluminium covering (which is about 10 per cent of the total plate thickness) has corroded away, as no pitting of the duralumin is likely until then.

Mild Steel

There is not much likelihood of cracks developing in this type of material, therefore the chief defect is again surface corrosion. This can

easily be seen because of the rust, which must be removed as early as possible. After cleaning, re-paint. The ground engineer should watch most carefully for corrosion of fittings and tubing at the welds.



FIG. 14. STAINLESS STEEL - INTERCRYSTALLINE CORROSION

Stainless Steels

These sometimes show signs of surface corrosion in the form of a reddish stain, but this can easily be removed, and the polished surface restored. Cracks may develop due to intercrystalline corrosion (see Fig. 14).

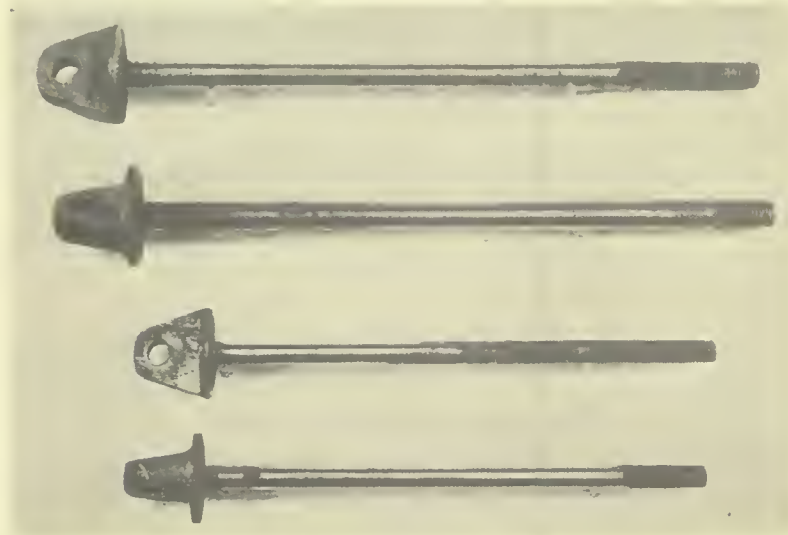

FIG. 15. STAINLESS STEEL - CORROSION

Stainless steels when in contact with wood, particularly in sea-going aircraft, should be frequently examined, as this may cause corrosion as in the case of the bolts shown in Fig. 15.

Of course, defects may be due to a combination of causes, for example, the combined effects of high stress and corrosion are well illustrated by the two photographs, Fig. 16 and Fig. 17. These cracks occurred in service in spars made from high-tensile stainless steel, and it should be noted that although they were primarily caused by corrosion, only very slight external evidence is present. It is unlikely that such cracks will be met with under normal conditions, but a careful examination of all components, from whatever material made, is obviously necessary when it is seen, as here, that such failures can occur.



FIG. 16. STRESS AND CORROSION CRACKS IN HIGH-TENSILE STAINLESS STEEL SPAR FLANGE



FIG. 17. STRESS AND CORROSION CRACKS IN HIGH-TENSILE STEEL SPAR FLANGE

Special Steels

Axle tubes (nickel chrome) may crack in service due to corrosion. These cracks are very difficult to detect; should there be any doubt the axle should be saturated with paraffin, and the suspected part afterwards dried and coated with whitening. If the axle is cracked the paraffin will percolate through the whitening in the region of the defect.

Copper Alloys

These are liable to surface corrosion (known as verdigris). Copper pipes may harden and crack or split where the ends have been bell-mouthed. Copper pipes should be annealed periodically at a temperature of from 600° C. to 700° C., and water quenched to re-soften.

Contact Corrosion

When two dissimilar metals are in contact, e.g. steel and duralumin, galvanic action which accelerates corrosion is set up between the metals. Great care should be taken during examination, as corrosion is very liable to exist, especially underneath fittings.

Streamline Bracing Wires and Tie Rods

Owing to the fact that bracing wires are very highly stressed in service and are manufactured from special high-tensile steel, great care should be

exercised in their inspection. The most probable causes of failure of these components are—

1. Corrosion.
2. Chafing at intersections.
3. Damage during refitting.

The following points should be carefully noted—

Corrosion

Before the bracing wires are fitted by the aircraft manufacturers they are coated electrolytically with metallic zinc or cadmium as a protective.



FIG. 18. BRACING WIRE WITH CLIP IN PLACE



FIG. 19. CLIP REMOVED REVEALING BADLY CORRODED AREA BENEATH

This coating is extremely thin (0.0005 in.) and great care should therefore be taken when fitting or adjusting such wires to avoid damaging this coating. On no account should emery cloth or any abrasive be used for cleaning purposes.

Corrosion is likely to appear after considerable periods of service in the form of rust spots which have penetrated the coating. These should be carefully removed by rubbing locally with a brush. The wire should be replaced if the metal is at all pitted underneath the rust. If, however, no pitting is visible the wires may be coated with grease or paint before further service.

The identification clips used on streamline wires are particularly liable to cause corrosion, being made from a metal dissimilar to that used for the wires. It is therefore most important that the clip be moved along the wire and that the portion hidden by it be carefully examined. Figs. 18 and 19 illustrate clearly the necessity for this precaution. If these clips are broken they must not be re-soldered as the necessary heat may impair the temper of the steel. Particulars given on damaged clips should be recorded in the log book, no new clips being fitted.

Chafing

The points of intersection of cross bracing wires are very important, as it is here that damage may be caused by the two wires rubbing together. Even a very small indentation on a streamline wire is dangerous, as the stress becomes concentrated at this point and may cause fracture.

The "acorns," fibre discs, etc., used at intersections should therefore receive careful attention, and if damaged must be at once replaced. Chafed wires must also be replaced and great care taken in their reassembly. The wires should also be examined for small cracks, particularly if they have had a long period of service or if they have been subjected to heavy vibration.

Refitting

When refitting or replacing a wire, the condition of the wiring plate holes and the correct alignment of the lugs should be checked. The fork ends and pins of the wire should be examined. When adjusting the length, and in order to avoid damage to the protective coating and the edges of the wire, a special spanner should be used. The lock nuts used must be of brass or cast iron so that if they are overtightened they will not damage the thread of the wire. The correct minimum amount of thread must be in engagement, as indicated by the wire reaching the small hole drilled in the fork end.

General

Careful watching and systematic inspection are always necessary to check corrosion in the early stages.

All open ended metal tubes must be inspected internally, as, although the external condition may be good, failures can occur due to internal corrosion.

6. OTHER MATERIALS

Fabric Covering

The fabric, sewing thread, and braided cord normally used for coverings and attaching the fabric to the ribs, are of the best quality linen. These materials must be carefully stored and the fabric should be kept in a room of fairly high temperature, 70° F. being suitable. This will ensure the evaporation of all moisture which would prevent satisfactory doping. Prolonged exposure to strong daylight is injurious to fabric.

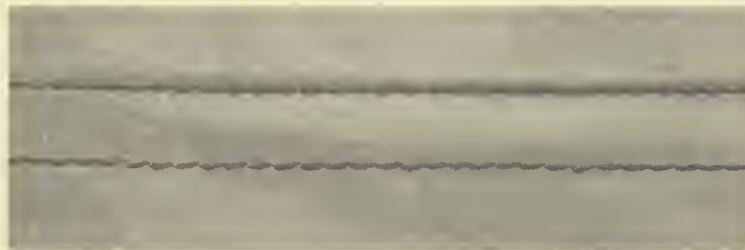

FIG. 20. FABRIC WIDTH TO WIDTH SEAM

Repair Work

To enable the repairs to fabric coverings to be carried out in a satisfactory manner, it will be necessary for the ground engineer to have a thorough

knowledge of wing covering, sewing operations, and the attachment of fabric to the ribs. These operations are very important, and every effort should be made to restore the damaged coverings as nearly as possible to their original strength and condition. The materials used on the aircraft undergoing repairs must be similar to those already used, and previous methods must be closely followed. The following notes are intended as a general guide. The type of seam used for joining fabric is the double balloon seam, and must be made as indicated in Figs. 20 and 21.

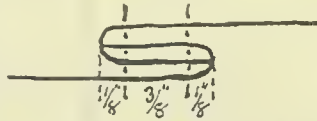

FIG. 21. CROSS SECTION OF SEAM

The machined seams should have approximately nine stitches per



FIG. 22. FABRIC ENVELOPE EDGE SEWN—STITCHES KNOTTED

inch, using single 40's linen thread. Hand-sewn seams are lock-stitched eight stitches per inch and double-locked every 6 in., using single 18's or double 40's waxed linen thread (see Figs. 22 and 23).



FIG. 23. FABRIC ENVELOPE—EDGE SEWING AND THREAD KNOTTING

The fabric is secured to the component by stringing to the ribs (Egyptian tape between) with braided waxed cord. The pitch of the stitches is 3 in., each stitch being knotted and doubly knotted at every 18 in. (see Figs. 24, 25, 26, and 28).

Special precautions must be taken when attaching the fabric in the region of the airscrew slipstream. For aircraft fitted with engines of 400 h.p. and over, the pitch of the stringing is reduced to $1\frac{1}{2}$ in. (see Fig. 27).

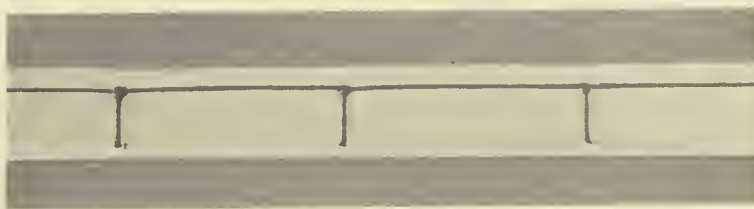

FIG. 24. FABRIC STRUNG (SHOWING KNOTTED SIDE) TO RIB

All stringing of ribs, and sewing threads around the trailing edge and/or end box ribs, must be protected by doping on serrated or frayed-edge tape (Figs. 29, 30, 31, 32, and 33).

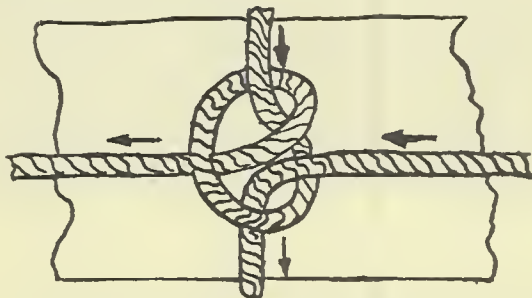

FIG. 25. RIB STRINGING. DETAIL OF KNOT

All repairs should be carried out as detailed above unless otherwise stated in the aircraft maker's approved handbook. If large sections of fabric need replacing, the new fabric, after joining to the remaining



FIG. 26. FABRIC STRUNG (OPEN PITCH) TO RIB

original fabric, should be drawn tight when sewing, and the tension must be uniform over the new area. Care must be taken not to overtighten the fabric on light structures as the additional tightening by doping may cause distortion. When repairing a small tear in the fabric, first remove

the dope around the damaged portion by the use of an approved dope solvent, or by peeling the old dope away, afterwards sewing the edges

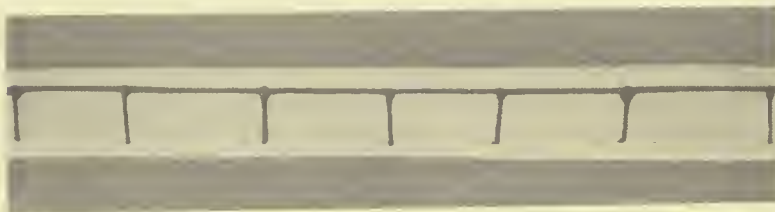

FIG. 27. FABRIC STRUNG (CLOSE 'SLIPSTREAM' PITCH) TO RIB

together and dopping on a suitable frayed fabric patch, then covering with the necessary coats of dope as called for under the scheme. Where the fabric

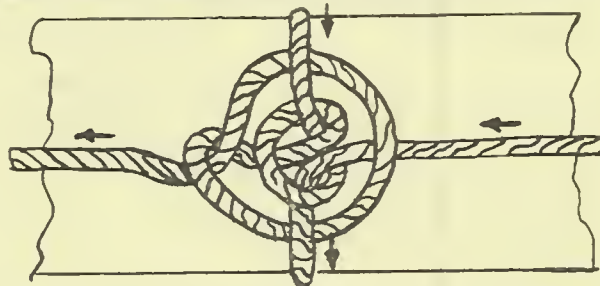

FIG. 28. RIB STRINGING, DETAIL OF DOUBLE KNOT

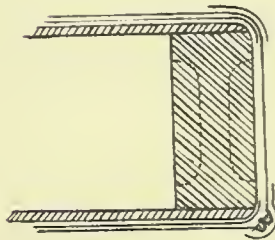

FIG. 29. METHOD OF ATTACHING FABRIC TO REAR SPAR

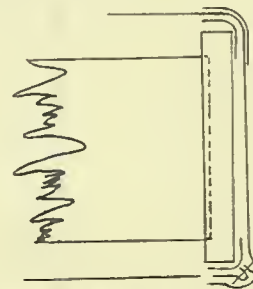

FIG. 30. METHOD OF ATTACHING FABRIC AT END RIB



FIG. 31. METHOD OF ATTACHING FABRIC AT LEADING OR TRAILING EDGES



FIG. 32. FRAYED-EDGE TAPE (ALTERNATIVELY, MAY BE SERRATED)

(Figs. 29-32 R.A.F. Official Crown Copyright Reserved.)

is badly torn the jagged edges should be cut away to a square or oblong shape and a piece of fabric of similar shape inserted, sewn in, and the repair finished as already described. Holes and tears in the coverings must be repaired immediately, as they may rapidly extend by tearing in the wind and the effect may further bring about alteration of the static pressure within the wing, which in turn might increase the normal rib

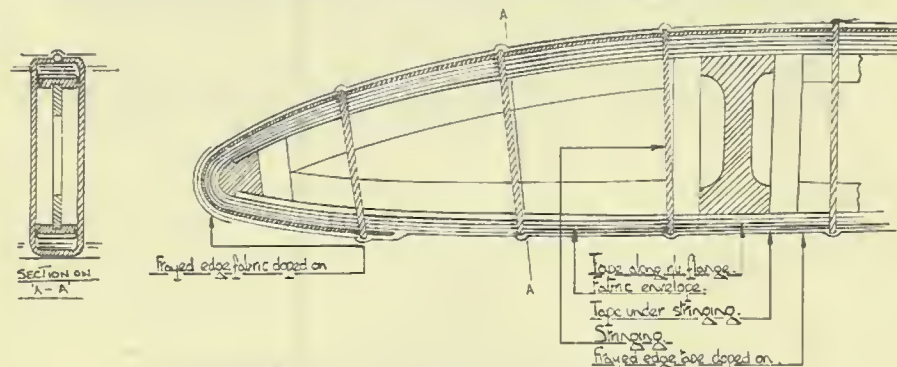

FIG. 33. SECTION OF FINISHED COVERED COMPONENT
(R.A.F. Official Crown Copyright Reserved.)

loading. The maintenance of fabric coverings is a very important item both for the safety and efficiency of the aircraft.

Doping of Fabric

Aircraft dopes are of two kinds: (a) acetate dopes; (b) nitro dopes. There are several approved proprietary doping schemes, and the makers of these schemes issue instructions for use, which must be followed. The complete doping of fabric-covered components is a method of producing and maintaining a taut, waterproof and airproof surface; it is a protective covering for the fabric. It prevents deterioration of the fabric by light, weather, and service conditions. Pigment is added to dope to protect the fabric from light rays, but as pigments absorb heat a final coat of aluminium is sometimes given in order to reflect the heat rays.

General Application Conditions

A fairly stiff brush should be employed, of which the bristles must be secured by rivets to avoid loosening by the solvents in the dope. The first coat of dope, which must not be thinned, should be well brushed into the fabric with sufficient pressure to ensure thorough impregnation. Further coats of dope may be brushed or sprayed in accordance with the approved proprietary scheme, which should also be the guide for between-coat intervals, number of coats, etc.

Atmospheric Conditions (doping scheme for workshops).

Doping should be carried out in a warm dry shop with a temperature of not less than 60° to 70° F., free from draughts, but having efficient ventilation. Moisture in the atmosphere should be kept at a minimum and the relative humidity should not exceed 80 per cent.

Doping Under Adverse Conditions

Doping schemes for repair or renovation of machines under aerodrome or unheated shop conditions permit doping to be done in the open air.

A sheltered place should be selected where strong draughts and gusts of wind are reduced to a minimum. The weather should be warm and dry; doping should never be done if the temperature drops below 32° F.

General Precautions

There is a tendency for the pigment to settle out with all coloured dopes, therefore great care must be taken to ensure that the containers are thoroughly stirred and shaken before and during use. It is also very important that dope, dope covering, cleaning solutions or brush wash, etc., of one scheme are not mixed with other schemes.

Defect and Deterioration

Dope on covered components may, with continuous service, become brittle and crack. This may expose the fabric to weather, which will cause the fabric to perish unless this defect is immediately corrected. The best remedy is to remove the cracked dope film by the use of a dope solvent, thoroughly clean, and redope. Another defect known as soggy fabric is due to the deterioration of the dope by long exposure to varying weather conditions; this particularly applies to dope on covered components fitted to marine aircraft which are often moored out for long periods. Soggy fabric may also be caused through neglect to clean off oil, which will in time not only destroy the dope film, but penetrate to such an extent as will result in the fabric perishing, thus rendering components unserviceable. If the dope film only is defective, clean off with dope solvent and re-dope strictly in accordance with the doping scheme on the remainder of the component or components. All fabric components should be kept as clean as possible and even small defects should receive immediate attention; this will preserve the covering and assist in maintaining the performance of the aircraft. The dope film may become chafed, damaged, or punctured locally, and may split or crack; the film should be peeled or dissolved from the area immediately surrounding the damage, and the fabric repaired if necessary, the place then being re-doped as already explained. The sharp places of the component—edges, ends, blocks, rib-peaks, and the walkways used by the ground mechanics during their work, etc., as well as all other areas likely to become prematurely worn, should be often and carefully noted and re-coated as required.

7. AIRSCREWS

There are many different types of airscrews, but those commonly met with in British practice are of two kinds; those made of layers or "laminae" of timber (mostly all-mahogany or all-walnut) glued together, and those of metal (solid light alloy).

Both mounted and unmounted airscrews should always be very considerably housed, in clean, ventilated, even-temperatired and sheltered situations. Spare airscrews should be stored with their leading edges downwards, supported on the boss and lightly held by a support cut to shape and packed about midway along each blade. It should be always carefully noted before fitting an airscrew that it is of the correct design and type for a particular type of aircraft and engine. Its drawing number, diameter (the circle in feet described by the tips in rotation) and pitch (approximately the forward distance in feet that would be moved through at one rotation if there were no slip) are always to be found stamped on or adjacent to the boss.

Great care is necessary when fitting the engine hub to the wooden

boss of an airscrew to see that all bolts are lightly tightened at first and finally drawn up both evenly and tightly. The bolts should again be checked after the first engine run on the ground and from time to time.

During the fitting operation care must be taken not to crush the timber by over-tightening.

It is necessary to check the track of the airscrew after it has been mounted and secured to the engine. To do this, place a trestle in position in front of the path of the airscrew and level with a point near to the tip. By the use of a fixed scribing block or some definite point on the trestle, measure the distance to the leading or trailing edge of each blade as it is brought round by hand. Errors may be due to incorrect tightening of the hub bolts. Various limits are laid down regarding the permissible track errors for airscrews of different diameter, and the margins stated for the manufacturer's handbook should be rigidly adhered to. The maximum error permissible to conform to A.M. requirements is ± 0.03 in. for airscrews up to 5 ft. diameter, increasing by ± 0.01 in. for every 2 ft. increase of diameter.

Damage to an airscrew may occur when the engine is running on the ground, due to small stones, etc., being drawn up. Scratches and small indentations in light alloy airscrews from this cause may be removed by a file or emery cloth, the places being made to "fade" easily and smoothly into the surrounding surfaces.

On seaplanes the protective covering becomes damaged by water spray during taxiing and take off. It is essential that any damage to the cellulose lacquer should be repaired without delay. Airscrews slightly out of balance should be corrected during the re-application of protective coverings.

Airscrews are often very highly stressed units, and any small defect in timber or metal (perhaps unnoticed during manufacture) may quickly develop. The boss, the hub bolt holes, the root and each blade's length, should be carefully gone over for signs and splits, flaws, or fractures of any kind. Glued joints should always show continuous sound adhesion. On wooden airscrews with blades covered with fabric the latter tends to become threadbare and to fray, also the edges of the timber, particularly towards the tips, sometimes become fibrous and ragged with heavy wear. Tip cappings, tipping and edging sheaths may also become loose. Tip drain holes should always be kept clean and clear. Light alloys often corrode very rapidly in the presence of sea water or ozone-charged atmosphere (see "Material Defects and Deterioration").

With airscrews made of light alloy, therefore, and particularly those used in coastal or similar places, this trouble should be carefully looked for, not only on the exposed faces but also on all portions which are covered by any other part such as the hub and spinner, etc. Corrosion once commenced cannot satisfactorily be arrested. An airscrew so affected should be removed and a replacement fitted in its stead.

The protective coating of airscrews should always be maintained in a first-class condition. An airscrew is said to be in static balance when the centre of gravity lies at some point along the axis of rotation. A statically balanced airscrew will exert no turning moment, however it may be positioned on the mandrel of the balancing machine. An airscrew lacking static balance will always exert such a turning moment except when in such a position that the centre of gravity falls upon a vertical line passing through the axis of rotation. The turning moment is greatest when the airscrew is positioned so that the line joining the centre of gravity and axis of rotation is horizontal. For this reason, when the static balance of

an airscrew is in doubt, the balance is checked at two settings at right angles to each other.

It should be tested on a suitable approved apparatus, consisting of a ground spindle either on accurately levelled knife edges, or by two pairs of large discs mounted on ball or roller bearings; the apparatus being kept in a position free from draughts and vibration. The apparatus should be of known accuracy. The airscrew should be within the limit of 2 in.-oz. for diameters up to 6 ft., increasing by 1 in.-oz. for each 2 ft. by which the diameter exceeds 6 ft. Moisture absorption by, or any repair work on, a wooden airscrew will seriously affect balance.

Any work beyond the re-application of protective coverings involving balance is best dealt with by the makers; the suspicion that blade angles (they will be measured in the shops with the airscrews on a surface-table, at certain positions or "stations" along the blade by a protractor) or that any other distortion whatsoever has taken place should receive the maker's attention.

The closest inspection should be made for material defects, and for lack of balance and incorrect pitch angle, as any of these may quickly cause excessive vibration.

Such important members of an aircraft should always receive the close attention which is their due, for engine and structural damage and serious danger may arise from an imperfect airscrew.

Airscrews should never be handled when hot (i.e. immediately after prolonged running) and during turning operations should always be held well in toward the root, particularly the light alloy type of airscrews, as these taper so rapidly and are very thin towards the tip. (Some airscrews are marked with boundary marks beyond which the airscrew may not be handled.)

8. CONTROL MECHANISM: DEFECTS AND DETERIORATION

All hinge pins, and also pins at the control column, should be inspected for excessive wear. Examine the run of cables for fraying, paying special attention to the portions that bear on the fairleads and the attachment of the cables to control surface. Operating levers should be inspected for wear and security, and the splices and eyes for corrosion and stretching. All attachment and control rods must be carefully inspected for wear and safety; if any control rods or cables pass through components such rods or cables must be removed and examined for corrosion more frequently on the lower planes and tail units of marine aircraft than would normally be necessary for land aircraft.

It is important that the control stops do not allow movement beyond the limits laid down. The travel of all controls should be checked from time to time, the control column being set in accordance with the maker's control diagram. Careful lubrication is required at all places provided and at all hinge pins and other moving parts, which must be cleaned from time to time for examination. All chains complete with attachments must be checked for stretching, and for wear and corrosion. Throughout the whole control system it is most important to inspect the split pins for wear and corrosion; the pins must be replaced if affected. All split pins must be of correct size and length and must have a washer between them and the fitting. Having once been taken out of a fitting they must on no account be used a second time.

When replacing cables or other parts of a control unit the whole system must be examined for correct functioning and travel of control surfaces

and travel attachments, for freedom and travel throughout the control range, and for locking of all attachments. After any replacements or adjustment of flying controls the examination must be duplicated.

Examination of Slack in Aircraft Controls

Undue slackness in the control system of an aircraft is liable to cause flutter; it is important, therefore, that special attention be paid to the fit of all control bearings, which should be as free from play as possible, consistent with ease of manipulation of the controls. Any slackness at these points will be magnified by the length of the control column, levers, etc.

Control cables which pass through or over fibre fairleads are to be left dry and not greased, as the grease picks up grit and abrasive matter which accelerates the wear of the cable.

9. INSPECTION AFTER A BAD LANDING

Land Aircraft

1. Jack up under fuselage until wheels are clear of the ground.
2. Remove landing wheels and examine hubs and brakes.
3. Check undercarriage struts for straightness. Renew if bowed or damaged, and inspect all points of attachment, bolts and pins for partial shear and holes for elongation.
4. Disconnect oleo legs at lower end and check axle for alignment.
5. Remove tail wheel or skid assembly, examine for distortion and excessive play, and inspect the structure at the points of attachment and along those members of the frame through which load is distributed.
6. Set fuselage in flying position, and check all rigging dimensions.
7. Remove all inspection covers, and check internal bracing wires; if these are very slack carry out further inspection of internal fittings, spars and attachment points. Never adjust bracing wires unless the cause of slackness has been discovered.
8. Unlace fuselage bag and examine internal structure for damage to longerons, struts, fairings, and bracing wires.
9. Inspect all controls. If the aircraft is fitted with folding wings these should be tested for correct functioning, and an examination made of attachments and locking arrangements.
10. Should the wing tip come heavily in contact with the ground, or any other object, examine the points where interplane struts are attached to the wings. Carefully inspect the rear spar and aileron attachments, also the wing root fittings. If the wing fabric is pucker the component affected must be opened up and checked internally, also the spars carefully inspected for fractures, i.e. splitting, crushing, and compression shakes. It is most important that a systematic inspection be carried out after a bad landing, and to emphasize the importance of this fact it must be remembered that the load on the bottom plane spars may have been transferred by the struts and bracing wires to the upper plane spars, and by virtue of the lift wires may have given compressive stresses to those members. These stresses can again have been reduced or increased by the tension in the front, and compression on the rear spars, caused by the drag component of the force applied by meeting the ground or other obstacle. It should be realized that damage may occur in a region remote from the point of contact, especially in the locality of the wing cellule attachments and also the anchorages of points carrying concentrated loads, e.g. petrol tanks and engine mountings.

Flying Boats

Heavy drift landing may damage the wing tip floats, in which case careful inspection of the float struts and bracing wires should be carried out. The attachment fittings of the wing tip floats to the main planes should be removed so that the spars can be inspected for crushing, splitting, or compression shakes. Should there be no definite failure of the spars in this respect, check internal wing bracing wires for correct tension, and examine fittings and main wing bracing wires at points immediately above float attachment fittings, also the interplane struts and their fittings.

HEAVY TAIL LANDINGS on flying boats invariably damage the leading-edge ribs and fabric of the tail plane.

Carefully inspect the whole tail unit and test rudder and elevator control cables for signs of stretching, and the operating levers and rods for distortion and freedom of movement. Check the tail adjusting gear for functioning and the tail plane struts for bowing. The front spar of the elevator along the line of the hinge pin fittings should also be examined for failure. A very heavy "pancake" landing on the hull may result in buckling of the planing bottom and sides of the hull, and damage may occur to the frames and steps. Carefully inspect for failure of material and check wing attachment fittings on the hull, on upper and lower planes, and upper side of wing root fittings to centre section.

Carry out further inspection as for land aircraft.

10. MISCELLANEOUS GEAR

Wheel Brakes

The modern landplane is almost universally equipped with wheel brakes, enabling it to be brought quickly to a standstill on landing, giving greater ease and rapidity when manoeuvring upon the ground, permitting chocks being dispensed with during engine tests, and offering its pilot a wider choice of landing areas.

Various kinds and types of braking systems are used, the description of one (Vickers) which hereafter follows—

It is shown diagrammatically in Fig. 34. Brakes are fitted to the four wheels of the main undercarriage (a large four main-wheeled aircraft is here considered) and are operated by compressed air. The master control is a double grip hand lever mounted on the control wheel, and operation of the rudder bar in the normal way gives differential braking to assist steering on the ground. An overriding control is used to lock the brakes for "parking" and when "running up" the engines. The various components which comprise the system are as follows—

(a) The hand lever master control, which is mounted on the flying control wheel. Operation of this lever controls, by means of cable transmission, the relay mechanism of the main control valve, and gives braking proportional to the load applied.

(b) The main control valve, which is placed under the pilot's floor, is connected to the hand control and to the rudder mechanism. This control is in effect a duplex relay valve and whilst the hand control actuates both valves equally, and gives compensated braking, the action of the rudder bar causes an increase of braking on one side and reduction on the other.

(c) The parking control, which is mounted on the engine throttle control box, operates the main control valve by means of a cable wire transmission and provides an overriding control which applies all brakes.

(d) The duplex pressure gauge on the dashboard is connected to the

main control valve and gives indication of the pressure existing in the line to the brake motors.

(e) The wheel brake units each consist of a simple, cam-operated, two-shoe brake of automobile type. The cam is operated by an external air motor, and the whole is mounted on a torque plate.

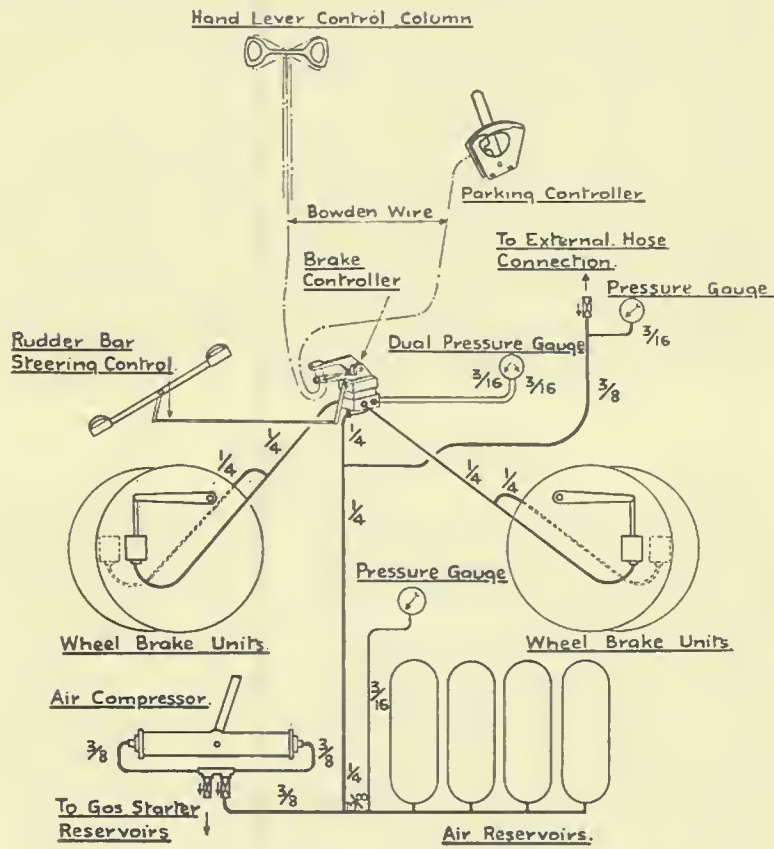

FIG. 34. BRAKE DIAGRAM

(f) The metal air storage reservoirs (unreinforced non-metallic reservoirs are not permitted), four in number, are fitted in one of the rear compartments below the cabin floor.

(g) The duplex hand air compressor is fitted below the cabin floor in the reservoir compartment. The pump is operated from the cabin, access being obtained through a door in the floor.

(h) The complete piping system connects all parts and is shown on the diagram.

The brake system is complete in itself, but provision is made whereby the reservoirs may be filled on the ground from the external connection, which may be coupled to a gas starter.

Method of Operation

Pressure applied to the hand control levers causes the relay valve to admit pressure to the brake motors, and gives compensated braking proportional to the load applied to the hand grip. Use of the rudder bar in the normal way gives differential braking for ground manoeuvres, and the change of pressure varies with the movement of the rudder bar. The pressure indicated on the duplex gauge need only be observed when testing the brakes; the action of the brakes in use will be entirely automatic.

The "parking" control, when fully applied, gives a braking force much higher than that given by the hand grip, and should be used only when the aircraft is at rest.

Before "taking off" a glance at the pressure gauge will ensure that the brakes are definitely "off"—pressure zero.

Full braking will be obtained as long as the pressure in the reservoirs is maintained above 55 lb. per sq. in.

Maintenance

The air pressure in the reservoirs should be maintained at 200 lb per sq. in. The hand pump in the cabin is provided so that ample pressure may be assured before landing.

Once before each flight the brakes should be tested to ensure that they are in order.

Tests

1. Ascertain that the pressure in the air reservoirs is between 180 lb. and 200 lb. per sq. in.
2. Apply brakes by hand lever—rudder bar normal. The pressures indicated on the gauge on the dashboard should then read 55–55 lb. per sq. in., or as required, depending on the particular installation.
3. Still holding hand lever on stops, move rudder bar for turn to port; pressures on gauge should now read: 75–30 lb. per sq. in.
4. Repeat above for starboard; pressure should then read 30–75 lb. per sq. in.
5. Bring rudder bar to normal, release hand lever: pressure zero.
6. Rudder bar should now be oscillated through full angle as in flight: pressure on gauge must remain at zero.
7. Pull "parking" lever to full extent and note that a pressure of 75 lb. per sq. in. is registered by both pointers. Any difference of pressure can be corrected by slight movement of the rudder bar.

If the machine is "parked" in gusty weather, the rudder control should be lashed.

In order to reduce to a minimum the amount of air used in braking, it is advisable, occasionally, to take up wear of the shoes by lengthening the adjustable screwed connection rod of the brake motor. This adjustment may be carried out while the wheel is resting on the ground, and should be such as will allow the end of the cam lever to be moved, say, 0.2 in. to 0.25 in. when the connecting rod is pulled by the hand in a direction parallel to its axis. No attempt should be made to alter the adjustment of the main control valve. This is a rather complicated mechanism, and if it ceases to function perfectly, it should be replaced by a new unit. It is very important that all joints in the air lines be kept tight.

When the aircraft is "parked" an occasional check on the pressure in the reservoirs should be made. Any serious drop in the pressure would

indicate a leak, which should be traced and rectified. When searching for air leaks, special attention should be paid to the various non-return valves which are fitted at points throughout the system, especially that nearest to the external hose connection. The brake units are fitted with oil excluders to keep oil or grease from the brakes. If at any time the braking seems defective, although the pressures are normal, it would be advisable to inspect the brake drums and shoes for oil.

When charging the air reservoirs by means of the gas starter pump, it will be obvious that DRY air and not carburetted air should be pumped in.

The hand air compressor in the cabin should receive an occasional small quantity of engine lubricating oil.

Description of Main Control Valve

The main control valve has many duties to perform, and it is essential that its method of operation be understood so that in any emergency replacement parts may be fitted and any minor adjustments carried out. This valve governs the maximum pressure which may be applied to the brakes at all times, and responds to the movements of the hand brake levers (mounted on control wheel), to the action of the rudder bar, and finally, to the "parking" control.

The valve box contains two identical groups of mechanism, one controlling the left-hand brake and the other those on the right-hand side.

Each group consists of an inlet valve (pressure), and exhaust (release valve), a rocking plate, its associated diaphragm and governing spring. There are also the connections to the air storage reservoirs and to the brake motors.

The diaphragm is acted upon, on the one side, by the governor spring load, and on the other by the pressure existing in the brake chamber (in communication with the brake motor).

When a balance exists between these forces the pressure in the brake motors and consequently the braking force bears a direct relation to the load on the governor spring, which is directly acted upon by the hand lever. The inlet and exhaust valves are also closed, and do not open again until the state of balance above referred to is altered. If it is desired to increase the braking, the load on the governor spring is increased by the application of greater force to the hand lever. This alteration of the balance causes the diaphragms to move upwards. The exhaust (release) valve then opens and allows air from the brake motors to escape until the pressure in the brake chamber again balances the governing spring load. When the brakes are entirely released the governor spring load is zero and the exhaust (release) valve is permanently open (pressure in brake system—atmospheric). From the above it will be seen that the maximum pressure obtainable in the brake motors depends upon the movement of the lever which loads the governor spring. The movement of this lever is limited by adjustable stops. The maximum loads on the governor springs are affected by the position of the rudder bar. In the foregoing the rudder bar has been assumed to be in the normal position. Movement of the rudder bar gives increased braking on one side and reduced braking on the other by means of the rocking differential lever.

The amount by which the pressures vary on a turn depends upon the angular movement of the rocking lever, and this has been fixed in this instance.

The only parts of the complete assembly which are likely to require attention are the valve seats. Should the valves leak it is best to replace the complete unit by a spare one. The faulty control may then be examined

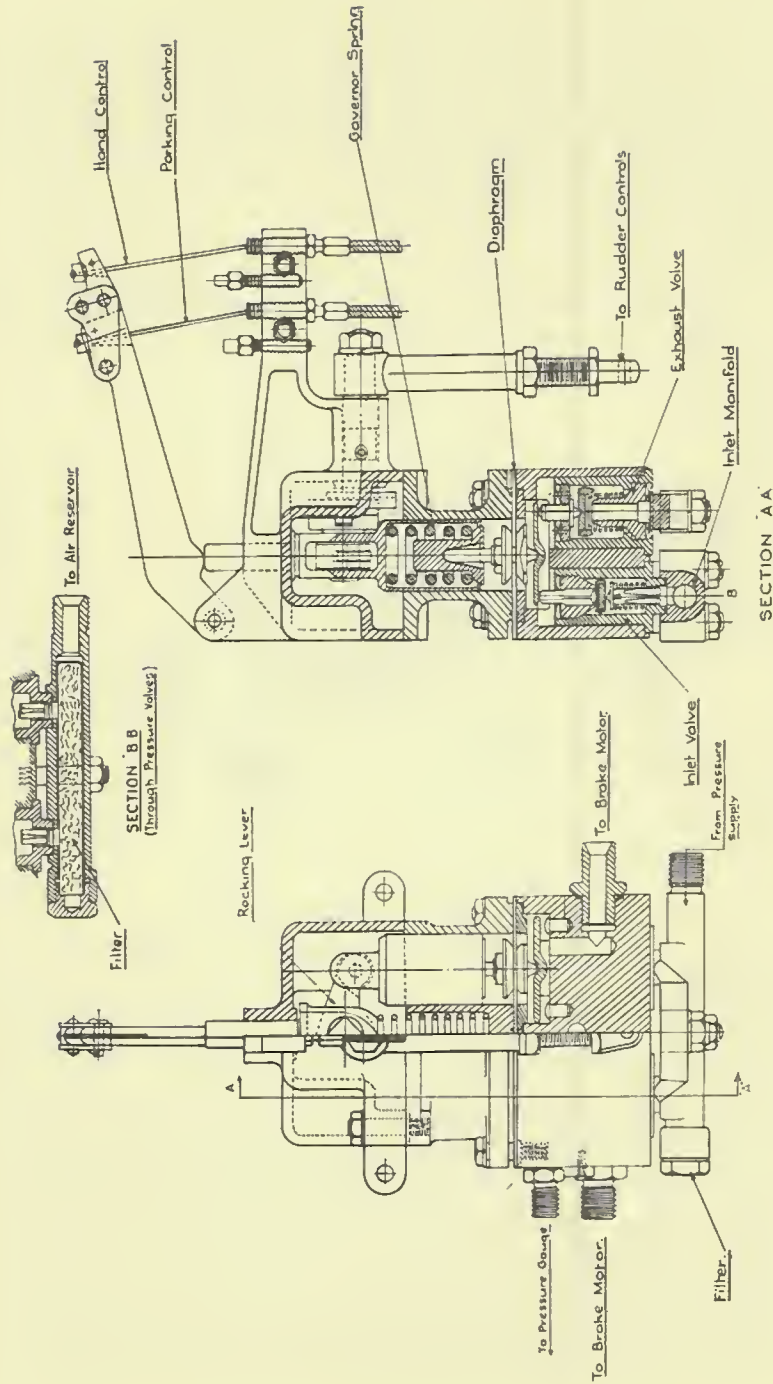

FIG. 35. BRAKE CONTROLLER

and the unit valves withdrawn and replaced by spare units. The unit valves are all made to jig and are interchangeable. Care should be taken that the replacement valves are fitted in the proper places.

In order to prevent any foreign matter getting in the valves, a horse-hair filter is fitted in the pressure inlet; for cleaning (in petrol) this can readily be withdrawn by unscrewing cap.

The main control valve is shown in Fig. 35.

Brakes

Bendix brakes (see Fig. 36) consist of two shoes (primary and secondary). The primary shoe is in contact with the cam block of the

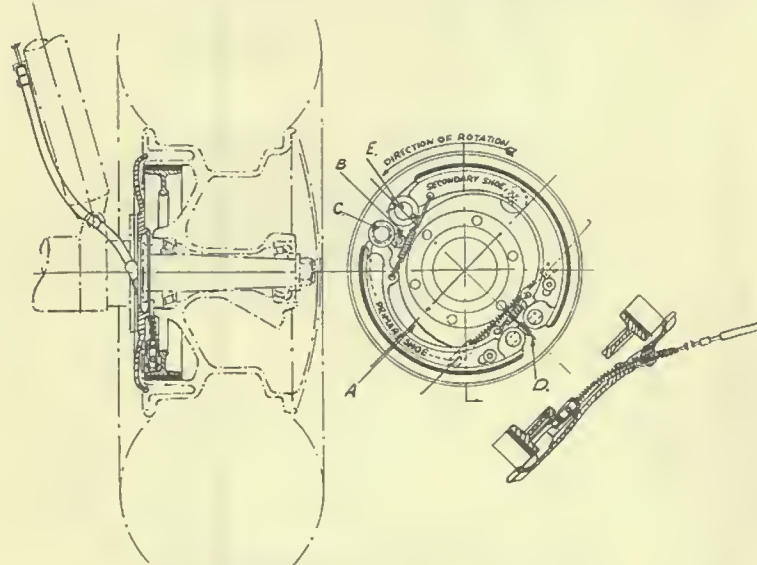

FIG. 36. TYPICAL BRAKE INSTALLATION

operating lever at one end, and is hinged at the other to lower end of the secondary shoe.

The other end of the secondary shoe is anchored to the brake back plate. The hinged connection between the two shoe brakes provides a means of adjustment and consists of a turn buckle, the inner portion of which is enlarged to form a "star" wheel.

In assembling, the hand brake lever is set so that in the fully-on position the pins are centrally adjusted in the running slots. When the rudder bar is moved to the right the fin comes to the end of its travel and so puts tension on the cable running down through the radius rod to the back of the brake drums. This gives a rocking movement to an arm bearing on the toe of the primary and heel of the secondary shoe and so tends to stop the wheel.

The adjustment of this brake (see Fig. 37) is simple provided the principle is understood. It is essentially the primary shoe that gives the power to the brake and not the tension applied to the hand lever. Smooth operation of the brake is impossible with any cables that are tight, or show any tendency to tension with the hand lever in the off position.

After connecting up the cable the wheels should be put on and the cables tightened, and a deliberate load applied to the hand lever to get as much slack out of the system as possible.

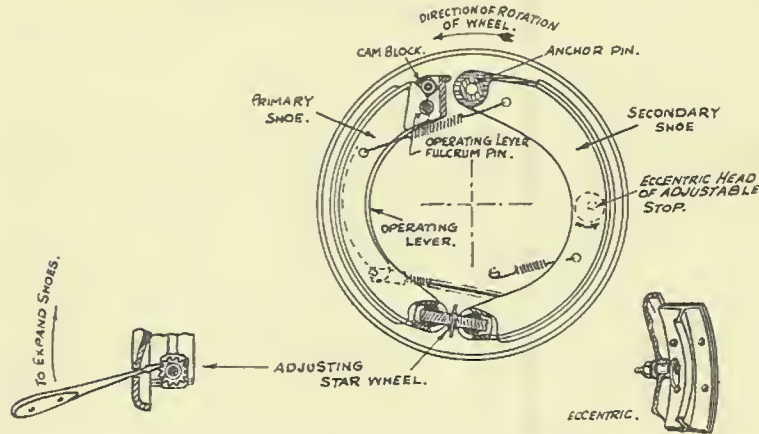

FIG. 37. BRAKE ADJUSTMENT DIAGRAM

The cables are then slackened off and the wheels removed, care being taken to leave the shoes in the centralized position. Now slacken or tighten the cables by means of the turn buckles, so that the cam between the toe of the primary and heel of the secondary shoe is free to shake.

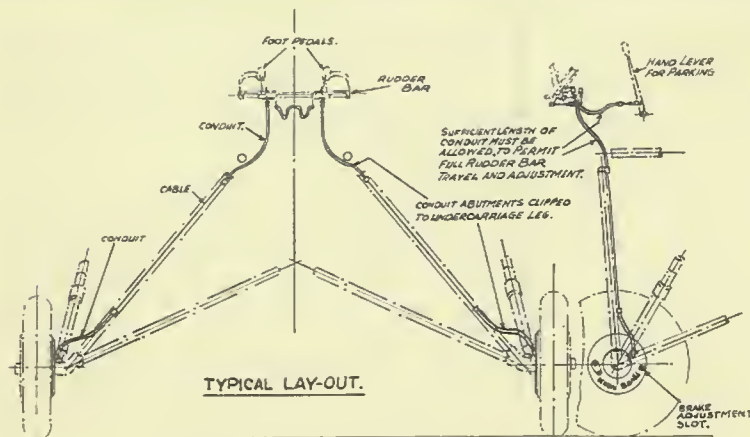

FIG. 38. TYPICAL BRAKE SYSTEM LAY-OUT

This adjustment is absolutely essential: practically all trouble with this type of brake originates in maladjustment here.

The wheel can now be put on and finally adjusted with the star wheel.

In assembling the brake, care should be taken to see that the star wheel is not assembled in the reverse position, which is quite possible. The

effect of this is to confuse the operator when the machine goes into service. The standard adjustment to tighten this brake is to move the handle of the screw-driver inwards and towards the axle. If this star wheel is reversed the shoe will be drawn in instead of expanded.

It is important to take up shoe wear only on the star wheel and *never* on the cables.

Shock Absorbing Devices

A perfect landing would be one where the stresses existing in an aircraft passing wholly through the air totally changed to those existent when it is wholly at rest on the ground, in a smooth, gradual, and evenly progressive manner, without any fluctuating reaction whatsoever.

Actually, no perfect landing (or take off either) ever occurs. The first contact of an alighting aircraft with the land or water, and the landing and departing runs over rough, broken, and undulating surfaces, imposes heavy shocks upon the structure. With marine aircraft the measure of the severity of such shocks depends entirely upon the conditions of weather and water, and the degree of skill with which the manoeuvring on, off, and on to the sea takes place. Similar conditions affect landplanes but with this great difference: incorporated in these latter, without exception, are devices which damp out the sharpnesses of impacts, smooth out abruptnesses, and aim to preserve for the remainder of the structure an evenness of keel and beam, while they themselves are resilient and accommodating, adjusting and readjusting themselves to the contact, speed, angles, and varying conditions (within reason) of the surface over which they are travelling. Such devices (which have been tried, too, on seaplane floats, but without sufficient success) have mostly taken the form of ties working in tension, or telescopic legs working in compression, and incorporating systems (singly or in combination) of elastic, rubber rings, bands, or balls, springs, oil through orifices, valves, or dashpots, and compressed air, which are directly interposed between the aircraft structure and the points of contact with the earth, whether skids, skis, or wheels. (It should be observed, incidentally, that pneumatic tyres on the last-named form, of course, in themselves excellent additional cushions). The devices form part of the main strut (or tie, as the case may be) system of the landing gear.

Of the methods of shock absorption mentioned, the general trend is to adopt at all points pneumatic tyred wheels in conjunction with the said telescopic legs, such legs being held extended by a system using oil and compressed air. The following is a description of such a device (Vickers Ltd.):

There are few moving parts, and these are automatically lubricated. The main gland is oil-sealed and no air can escape at this point: the filling valve is also oil covered. Both this valve and the oil-level valve are of the needle type and should retain the air indefinitely. The gland on the stem of the filling valve only comes into action during filling or testing operations. In order to obviate the risk which might accompany the removal of the main gland cap or screwed plug whilst there is still pressure in the air cylinder, the oil-level valve is interlocked with this part. It is therefore necessary to remove completely the oil-level valve before proceeding to dismantle the unit. The working surfaces of the air cylinder and piston are ground. The principle on which the system works is that any inward movement of the piston will compress the air. The increase of load due to increasing air pressure follows a definite law, and is practically independent of speed.

A large degree of lateral stability is given to the machine when taxiing.

The piston is always under air load and is always striving to return to its extended position. When the piston is forced inwards the oil is forcibly ejected by the entry of the brake ram and caused to pass into the interior of the air cylinder through the annular orifice. This orifice is of relatively small area, and the velocity of the oil through the same is very great and consequently gives rise to a high pressure in the chamber, with a corresponding retarding effect on the piston. The oil brake converts the excess energy of the landing into heat; this heat appears in the oil and is immediately dissipated by radiation from the exterior of the unit. The amount of energy which the oil brake is called upon to deal with, and the retarding force which it exerts, depend upon the speed at which the piston moves. If the piston is pushed in gently the retarding force of the brake will be negligible. The form of the brake ram provides the necessary retarding force as the speed of the machine falls away in coming to rest. With this combination it will be seen that great amounts of energy can be absorbed and dissipated without overstressing the machine structure.

The outward movement of the piston is controlled by an oil dashpot, which acts as follows. As the piston moves inward an annular space is formed between the piston head and the lower part of the cylinder. This space is filled with oil which passes freely through holes in the piston head and around the plate valve, which is suspended from the piston head. When the piston commences to move outward the plate valve closes and traps the oil. The rate of return of the piston is then controlled by allowing the oil to pass back to the air chamber through a small hole in the plate valve. The speed at which the piston returns is sufficiently great to enable the wheels to meet recurring shocks in taxiing, but not sufficiently great to cause bouncing. The main gland is self-adjusting and is packed with oil-tight rings.

The proper action of the strut or leg depends upon the oil quantity and air pressure being maintained within reasonable limits. When the strut is initially assembled a stated quantity of oil is put into the cylinder. As the main gland is absolutely oil-tight, and as we may assume that the unit will be serviced with dry air, there is no further need to test the oil level until the strut is dismantled for reconditioning at the end of one year, or earlier if a fault develops.

The struts are best stored filled with the measured quantity of oil but with no air pressure. If it becomes necessary to store them with air and oil ready for immediate use, then they must be stacked in a vertical position, cylinder on top. The best air pressure for a given application is found by trial, but as a general rule the air pressure is such that the piston floats at 75 per cent extension when the machine is at rest and carrying full normal load. Any variations between light load and overload are accommodated automatically by the movement of the piston outward or inward until the air pressure balances the load. The state of air pressure in the units on a machine can be readily determined by inspection of the red indicator line usually painted on the oleo fairing. This line is about 1 in. wide and so long as part is visible when the machine, at rest, is carrying full load, the air pressure is right. The freedom of the pistons can be checked by noting the amount of piston travel in normal use; this movement should be at least 50 per cent of maximum possible travel. The air pressure stated on the instruction label is that which is obtained when the piston is fully extended and carrying no load.

Some ground engineers insist upon testing the oil level and the pressure in the unit at stated periods when in service. This is not normally essential in view of the above, but verification when necessary may readily be

made in the following manner: Connect the special hand pump to the filling valve and raise the pressure in the pipe line to the nominal pressure in the air cylinder. The filling valve should then be opened by unscrewing it half a turn. The air chamber is now in communication with the pipe line and pressure gauge. If the oil level valve is now gently unscrewed, air or oil will

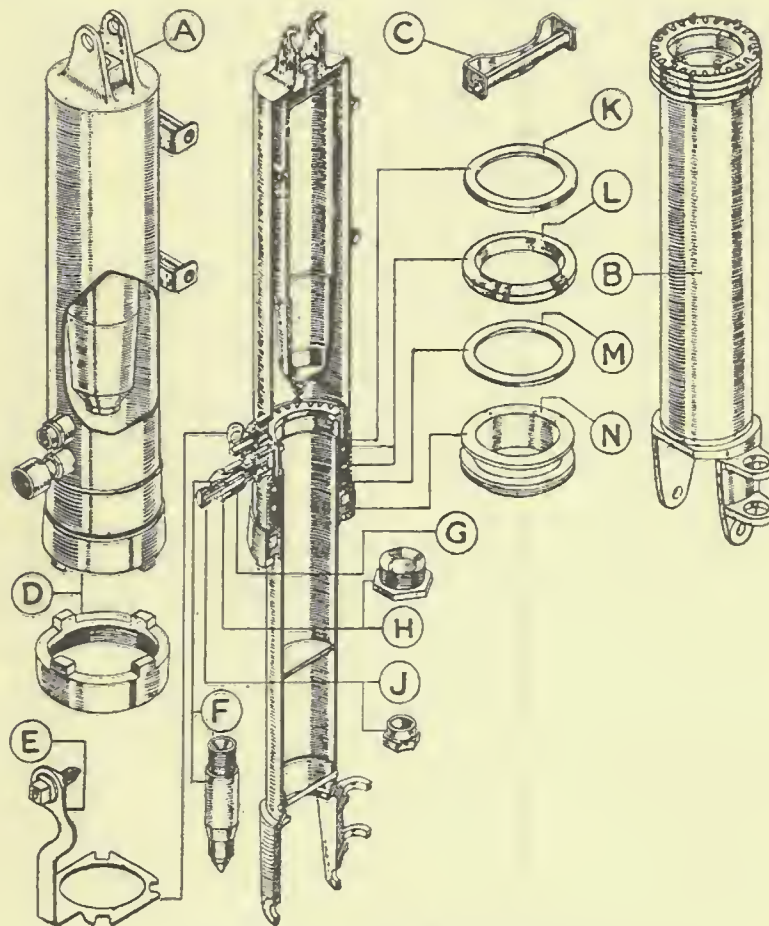

FIG. 39. DETAILS OF OLIO-PNEUMATIC LEG

be blown through the hole in this valve and will give an indication of the conditions existing inside the cylinder. It will be necessary, say, to insert a small quantity of oil, and this is done by pouring a quantity of machine gun oil into the reservoir at the top of the pump and continuing pumping. When oil commences to flow from the oil level valve it should be firmly closed and pumping continued until the gauge shows that the normal pressure has been reached. The filling valve should then be closed, after

which the pump is disconnected. Finally make all valves safe and replace the dust-cap.

It is essential that the piston be fully extended when the unit is being checked for oil level and air pressure. No attempt should be made to increase the air pressure beyond that indicated on the label. The sliding external portion of the piston should be kept free of any sand or grit.

A number of hypothetical cases with faults, reasons, and remedies are here given—

- | | |
|--|---|
| (a) Piston does not move or only moves a small amount when taxiing. | Air pressure too high, or gland has become gummy through long period of inaction. Remedy—reduce air pressure. |
| (b) Piston does not extend to normal and machine wallows on a turn. | Air pressure too low. |
| (c) Piston extends normally and air pressure is correct, but machine still rolls over badly on a turn. | Oil level too low and air pressure does not increase fast enough with inward motion of piston. Remedy—check oil level. |
| (d) Piston at normal extension and air pressure correct, but machine very harsh on taxiing. | Oil level too high, causing undue increase of air pressure with movement of piston. Remedy—check oil level. |
| (e) There is evidence of loss of oil at main gland. | If leakage is very slow keep unit in commission by maintaining air pressure. Replace complete unit as convenient. The gland of the defective unit must be dismantled and faulty packing rings replaced. |
| (f) If the air pressure in the unit is not maintained. | Ascertain that all valves are tight, and if the leak still persists detach unit and submerge in water to locate fault. |

Tail Skid

Tail skid types vary. A tail skid usually consists of a simple lever of the first order, the fulcrum of which hinges on a post or tripod arrangement fixed in the fuselage and having a shock absorbing medium for balancing the load at one end and a hard-wearing shoe at the other. The skid may be fixed, or may be freely tracking, or may be controlled partially or wholly in unison with the rudder.

The skid should be examined for buckling or fracture, the fulcrum points for slackness, struts or stays for bending, attachment lug holes for elongation, pins for shear, collars and bearings for wear, the shock-absorbing medium for general soundness, and the whole for general locking and security.

The tendency upon modern aircraft is to incorporate a small oleo-pneumatic strut (see "Shock Absorbing Devices") in conjunction with a tyred wheel (see "Wheels" and "Tyres").

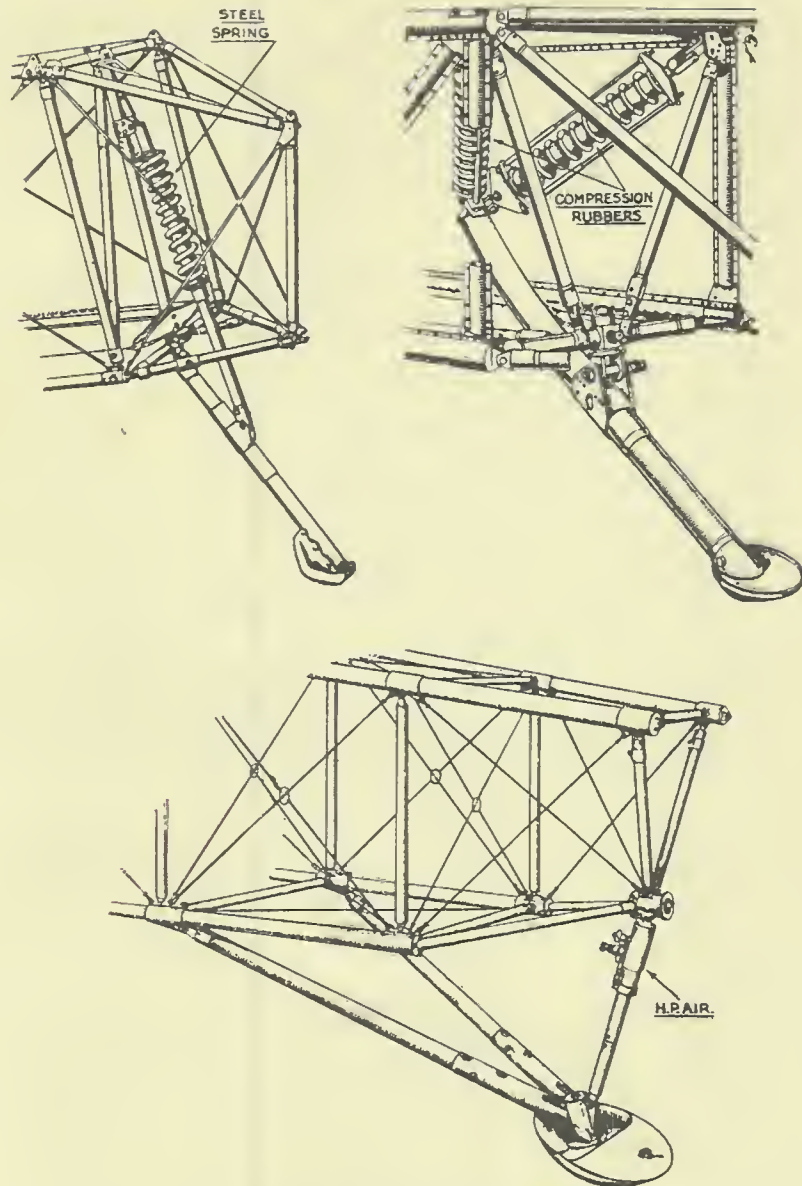

FIG. 40. TYPICAL TAIL SKIDS
(From A.P. 1107, by courtesy of the Controller, H.M.S.O.)

Tyres

The purpose of the aeroplane tyre is to interpose a pneumatic cushion between the aeroplane and the ground surface and to prevent undue shocks being transmitted to the aircraft, i.e. to minimize irregularities when taxiing to take off, or in the final run after landing, and to act as a shock absorbing medium when the aircraft first touches the ground on landing. The successful use of pneumatic tyres depends upon the maintenance, whether the tyres be in service or standing by, of the correct inflation pressure for the load as recommended by the manufacturers.

Maintenance

- (a) Excessive wear may be due to the wheels not being in line.
- (b) It is harmful to allow tyres to stand or to become bespattered with oil or grease.
- (c) Tyres become badly cut about from flints and other sharp objects. The covers should be periodically examined for deep contusions.
- (d) In some cases the inner plies of the covers break down and may give rise to swellings. Should a hand lightly passed over the cover be sensible of such swellings the cover should be removed, and if fractures are in fact existent a new cover should be fitted.
- (e) Tyres under ordinary and normal circumstances should be taken down for general examination and for inspection at any signs of perishing.
- (f) Tyres preserve their structure and resiliency best in a cold and damp atmosphere; so far as conditions permit, therefore, and without prejudice to other parts of the aircraft, continued heat and dryness should be avoided.
- (g) Should the aircraft be stored, jack up so that no weight remains on the tyres. If this is inconvenient, move the aircraft periodically to ensure a fresh area tyre is in contact with the ground.

The complete tyre should always be maintained in a good and sound condition. It should be borne in mind that a tyre-burst or failure whilst an aircraft was landing or taking-off at speed would be a dangerous and hazardous happening.

Wheels

Care should be taken during removal or fitting operations to avoid any damage to the protective surface coating. The bearings should be re-packed with grease from time to time, and in the case of wheels fitted with brakes more care is necessary with lubrication. Over-lubrication may result in grease finding its way on to the brake drum and impairing the efficiency of the brake.

Flotation Bags

These may be fitted in land aircraft to provide a period of buoyancy in the case of a forced descent upon water. The bags are interconnected by piping, and remain open to atmospheric pressure, a stop-cock being closed by hand immediately prior to the "landing." The material from which the bags are made is a rubberized fabric, which should be examined for deterioration when in use. Points of likely damage or chafing against the structure should be suitably taken care of. The system should be pressure tested to $\frac{1}{4}$ lb. per sq. in. (or 7 in. head of water) by means of a U-tube. The fall in pressure must not exceed $3\frac{1}{2}$ in. of water during test.

A suitable period should be allowed to elapse between the initial imposition of pressure and the test, to permit the temperature of the air in

(Extracts from A.I.D. Leaflet 11A, by courtesy of the Controller, H.M.S.O.)

the system to equalize with that of the shop or hangar. Any drop in pressure observed should be corrected before the actual test is commenced. Care should be taken that the air bags are not exposed to radiant heat (direct sun's rays) during test. Bags may be individually tested by the application of soapy water (which must afterwards be properly washed off) around seams.

11. GENERAL MAINTENANCE AND MINOR REPAIRS

Cleanliness

The fabric of the aircraft must be kept clean and free from oil, in order to avoid deterioration. To remove dirt and oil from the fabric, rub it well with a piece of waste or rag soaked in warm soapy water. Having removed all dirt and oil, wipe the fabric with a piece of dry cloth.

Mud thrown on to the fabric by the wheels of the undercarriage should not be allowed to dry, but should be removed as soon as possible. If, however, it has become dry, it should be taken off with warm water and not scraped off, as the fabric is liable to be damaged by scraping.

Control Wires

After every flight pass the hand over the control wires and carefully examine them near pulleys and fairleads. Even if only one strand is broken the wire must be changed. The aileron balance wire on the top plane must not be forgotten. Once a day try the tension of the control wires by moving the control levers about smartly.

Wires

See that all wires are kept well greased or oiled, and that they are adjusted to the correct tension. When examining the wires, make sure that the aircraft is on level ground, as otherwise it may get twisted, throwing some wires into undue tension and slackening others. The best way, if you have time, is to pack the machine up into its "rigging position." Should a slack wire be discovered it does not follow that this should be tensioned. The aircraft should be placed in rigging position and the cause traced. It may be that the opposite wire is stretched, the fitting pulled, or a component bowed, etc.

Carefully examine all wires and their connections near the aircrew.

Distortion

Carefully examine all surfaces, including the controlling surfaces, to see whether any distortion has occurred. Should distortion be discovered the defect must be very carefully traced and rectified. It may be that a wire has been unduly stressed, causing a rib to buckle. Slackening back the wire would not effect the repair as the rib would have become fractured, or the glue or securing loosened.

Undercarriage

Constantly examine the alignment and fittings of the undercarriage, and the condition of tyres, shock absorbers, and the tail skid.

Special care should be exercised when examining the "Oleo" type undercarriage.

Cleaning of Metal Fittings

When metal fittings require cleaning, all forms of scraping, such as rubbing with emery cloth or a wire brush, should be avoided. A paraffin bath and a soft brush or rag soaked in paraffin should be all that is required.

When removing paint or varnish, no abrasive methods should be employed, but the covering material should be softened with the varnish remover and rubbed with a rag soaked in this solvent. Stove-enamelled fittings are not usually treated with zinc or cadmium, and therefore the normal methods of removing stove enamel may be employed. After removal of the defective paint or varnish, all fittings should be re-coated with the appropriate protective covering with the exception of the side and bottom fuselage cowlings and the metal parts of undercarriages and radiators. These parts, if desired, need not be re-painted, but may be kept clean and bright by using metal polish or an oil-soaked rag.

Inspection Doors in Planes

Metal inspection doors in main planes should be very closely watched, especially if situated in the slipstream region, as fastenings which would normally be regarded as quite secure may possibly become detached through vibration and the effects of the slipstream. Should this occur the inspection door may fly back with considerable force, involving a possible injury to the pilot or the fouling of control mechanisms.

Rip Off Patches on Planes

Inspection doors are usually provided only at those positions where frequent inspection or lubrication of the internal fittings is required. Where only occasional inspection or adjustment is required for internal fittings, such as bracing wires, a special form of patch is used which is capable of being torn off and renewed as necessity demands. There are several types and shapes, but in all cases a light frame is secured to the fabric covering of the wing and the fabric enclosed by the frame cut away, thus providing a hole with a non-frayable edge. A covering patch of frayed fabric large enough to envelope the frame is then doped on to the plane over the hole. When it is necessary to place a rip off patch on a plane, the frames should preferably be of the circular type with an internal diameter of $4\frac{1}{2}$ in. to 5 in., but other shapes can be adopted to suit special conditions.

Care of Shock Absorbers

The shock absorber legs on the undercarriage of any aeroplane should be of equal length under any given load, and where this is not the case, an examination should be made to ascertain the cause of the unequal extension. Gauge marks are normally provided to indicate the approximate safe minimum length.

Repairs and Maintenance

After an aeroplane has been assembled and flown, there are manifold duties connected with the maintenance of the aeroplane in a sound and airworthy condition. This entails a regular and systematic examination of all parts, with the consequence that adjustments and minor repairs are found necessary from time to time, quite apart from the repairs necessitated by a more or less serious mishap to the aeroplane such as might be occasioned by a forced landing. If an aeroplane is seriously damaged, but not sufficiently for it to be struck off charge, it is usual to strip the aeroplane completely, dismantle the damaged portion, substitute complete components for those badly damaged, and repair the parts which are only slightly injured. The repair and maintenance notes for the type usually specify the limit of repairable damage, and the details provided generally cover all normal eventualities. The repair and maintenance notes are either issued separately or incorporated in the aeroplane handbook.

The methods of repair vary in accordance with the type of construction used, and it is obvious that a repair which is suitable for one type of aeroplane will in most cases not be suitable for another type. It is highly important, therefore, that only those repairs should be used which have been approved for the particular type of aircraft, and which are enumerated in the repair notes.

Rigging Allowances

Rigging notes and instructions generally give the angles and dimensions in exact figures, but in practice it is seldom possible to work to the exact dimensions given. A tolerance is therefore permissible on all dimensions.

The allowances to be made vary with different aircraft, obviously depending mainly on the type and size of the aeroplane and the magnitude of the dimension.

The utmost care must be taken to avoid damage to the structure owing to an attempt to work to too strict a tolerance; on the other hand, no effort should be spared to obtain the closest approximation to the rigging dimensions that the normal adjustments will allow.

Inspection

After re-assembly, necessitated by repairs, the aeroplane should be completely inspected before it is passed as fit for flying. The inspection should be made methodically and in accordance with a system. The system usually adopted is to divide the aeroplane into a number of logical and convenient groups, and deal with each group in a definite order. The grouping normally employed is: undercarriage, fuselage, tail unit, cockpits, mainplanes, airscrew, and general. During the inspection of each group, the inspector should, as far as the group lends itself to such procedure, always go round it in an anti-clockwise direction, examining each individual part in detail as it is encountered.

Detachable Fairings

When the flush fitting type of cowling clip is used, special precautions must be taken to ensure that the clips are actually securing the fairing to the structure, as the fairing is in a dangerous condition if one of the clips does not catch as it should. It is usual to arrange for the screw-driver slots or other operating mechanism to be all in one direction so that the position of the catch can be ascertained at a glance. If this has not been arranged, suitable marks should be made on the clip, the marks being all in one direction when they are attached.

Protection Against Corrosion

One of the greatest enemies of metal aircraft parts is corrosion. An infallible and everlasting remedy for corrosion which is of practical utility has yet to be found for the majority of ordinary metals. The greatest advance within recent years was the introduction of stainless steel. The use of this material, of which there are several varieties, appears to be a solution of many problems connected with corrosion. Materials used on aircraft which demand the greatest care from the aspect of corrosion are ordinary steels and light alloys. Steels by themselves do not corrode at a greater rate than many other metals, but on account of their greater tensile strength they are generally used in much thinner gauges than other materials, and are therefore more susceptible to deterioration owing to this cause. Light alloys which have a basis of aluminium or magnesium are inherently unstable, and given an opportunity will corrode very

quickly. The corrosion which occurs in these materials is not always attributable to exterior causes, but it may be due to the interaction which occurs, due to impurities in the metal. For both steels and light alloys the basic principle of protection against corrosion is to exclude the air from contact with the metals. If, therefore, corrosion is to be avoided, it is imperative that the protective covering should remain intact, or if, owing to mishandling or service usage, the protective covering has become damaged, it should be renewed immediately. The usual protective media employed include paints, varnishes, enamels, sherardizing, hot galvanizing, costettizing, cadmium plating, anodizing, and metal spraying, all of which have been devised with the object of defeating corrosion.

CHAPTER III
SEAPLANES AND FLYING BOATS

12. ORDER OF ERECTION (FLYING BOATS)

PRIOR to the erection of the component parts of the aircraft, the hull, supported in its cradle, is adjusted to rigging position. The order of erection adopted by manufacturers is as follows—

1. Hull adjusted to rigging position.
2. Tail unit erected on ground and lifted into position.
3. Bottom centre plane attached and engine mountings (with oil tanks) assembled.
4. Petrol tanks installed in top centre plane, and top centre plane, with centre section struts, fitted.
5. Engines installed.
6. Top outer planes erected with ailerons in position.
7. Outer interplane struts attached and bottom outer planes, with ailerons, erected.
8. Interplane struts, aileron struts and bracing wires connected up.
9. Wing tip floats fitted.
10. Alternatively the complete superstructure can be assembled on suitable trestles and lifted as a unit on to the hull.

Levelling Boards

13. RIGGING

A complete set of straight-edges, incidence and dihedral boards for the rigging are usually supplied by the manufacturers. (The incidence and

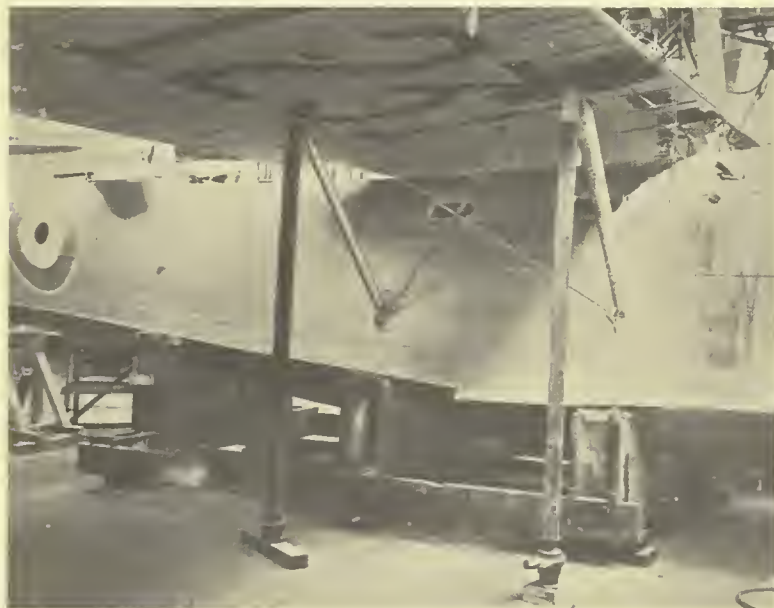

FIG. 41. HULL IN CRADLE AND PROPS UNDER PLANE CHOCKING BLOCKS

dihedral boards are illustrated and the method of use shown in Figs. 6 and 7, Chapter I). If the boards are not available the aircraft can, of course, be rigged in the usual manner by measuring the angles with a straight-edge and inclinometer.

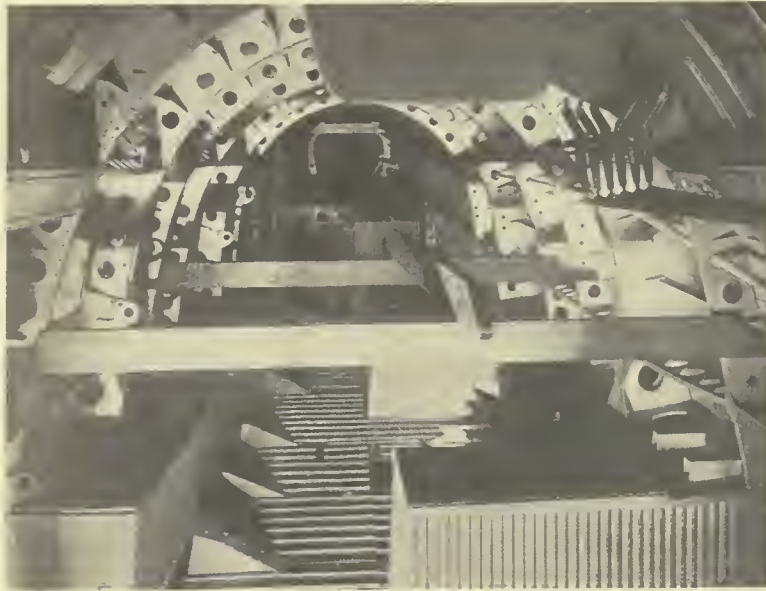

FIG. 42. PERMANENT LEVELLING BLOCKS (SHOWING STRAIGHT-EDGES IN HULL)

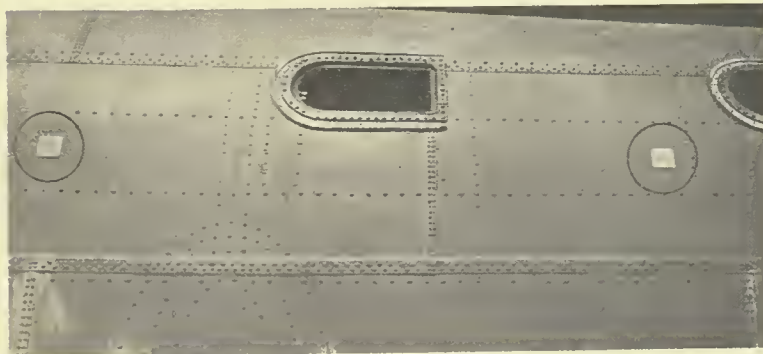

FIG. 43. DATUM-MARK PLATES ON OUTSIDE OF HULL

Rigging Position

The construction of the hull does not allow any adjustment or truing up. The hull is placed in position on its supporting cradle and the latter adjusted by means of suitable wood packing blocks and wedges (Fig. 41) until the straight-edges are horizontal laterally when placed inside of the hull on the permanent levelling blocks, positioned as indicated in Fig. 42,

and longitudinally either by level and straight-edge along the datum lines (see Fig. 43) or internally by bridging straight-edges on the two lateral stations by a straight-edge fore and aft.

Assembling the Tail Unit

The tail unit should be placed on felt-covered boards arranged to give adequate support to the under-surface; then the fins, rudders, inter-rudder struts, elevator, and control connecting rods are assembled. The complete unit can then be lifted into position, and attachment made to the hinge fittings on the hull and the main spindle of the adjusting gear. The struts and auxiliary stays from the hull to the tail plane front spars, and the struts from the lower end of the adjusting gear spindle to the rear spar are then fitted, and the complete unit trued up. The lower (hull) ends of the tail plane struts are usually provided with adjustable sockets which are secured to the lug plate fittings on the hull and tail adjusting gear. Short straight-edges, laid along the spars on either side of the central fin, should be horizontal when the hull is in rigging position. If necessary, adjust the struts to secure this condition.

It is sometimes found that alteration of the length of the tail plane struts produces slight local distortion of the stern of the hull, with consequent binding of the rudder and elevator transverse torque shafts. Particular note must be taken, after erection of the tail unit, that these shafts are quite free to rotate.

Assembling and Rigging the Centre Section

The centre section may be assembled in two ways; either by erecting the bottom and top planes separately, or by assembling the whole unit and lifting it on to the hull. Where facilities exist, the latter is the best and the most convenient method.

When the planes are to be erected separately, the bottom centre plane is lifted on to the hull and the front and rear spar attachments completed. The front and rear support struts from the hull (the upper ends of which are adjustable) together with the incidence bracing are then attached, the plane being supported at the ends meanwhile. The bottom plane should then be tested for horizontal level, using the blocks provided for that purpose. The incidence of the plane should now be checked. If necessary slight adjustment for incidence can be made by varying the length of the supporting struts. At this stage it is advisable to test the bottom plane for squareness to the centre line of the hull. This is checked by measuring the distance of a point on each end of the front spar from a point at the nose and on the centre line of the hull; these distances should be equal. If any adjustment is necessary it can be effected by means of the under centre section bracing. In some types of aircraft which have built-in bottom centre sections as an integral part of the hull, no provision is made for the adjustment of the lower centre section after the hull is completely plated.

The top centre plane may now be erected. The plane is lifted into position with all the interplane struts fitted. When completely erected, the stagger, if any, of the two planes must be checked by dropping plumb lines from the leading edge of the top centre plane (see Fig. 8). Care must be taken that all struts are fitted in the correct position, as some may have dead length struts, and some adjustable screwed sockets in the lower ends.

This screwed type of socket is a standard one for adjustable struts which are structural members of the aircraft. In altering the length of any of these, care must be taken to ensure that the male portion of the

socket is not screwed out so far that it cannot be felt when a wire is inserted in the inspection hole drilled in the strut end, as otherwise the number of threads of the socket engaged in the strut will be insufficient for strength.

Where it is possible to lift the complete centre section as a unit on to the hull, the following procedure should be adopted. Raise the bottom centre plane on trestles, suitably padded and preferably set to the correct incidence, and then assemble on it the top plane (with petrol tanks) interplane struts, incidence bracing wires and engine mounting. Completely true up the centre section. Lift as a unit on to the hull and complete the attachments. Tests can then be made for horizontal level and incidence of the bottom plane, stagger if required, and squareness of the centre section with the hull.

Attaching and Truing Up Outer Main Planes

Where only one pair of interplane struts is used for each outer section, it is not possible to "box up" the outer planes on the ground and hoist into position. The top planes, with ailerons held fast in neutral position by top and bottom battens, secured by bolts and wing nuts through the space between wing and ailerons, are erected first, and supported by slings, whilst all the interplane struts are attached and both bottom planes erected. The struts are then attached to the bottom planes and the front and rear landing wires inserted. As a precaution an extra support should be arranged under the engine mounting on the side of the first bottom plane erected, to take the weight and thus counteract any tendency to disturb the hull in its cradle. The incidence and flying wires are then fitted and all supports removed. Lastly, the interplane bracing is trued up until the correct settings are obtained.

Assembling the Wing Tip Floats

The float struts should be fitted to the floats before attaching to the planes. Attach the float struts to their respective fittings on the front and rear spars and the bottom outer planes, then fit the incidence and bracing wires. When correctly erected the float struts should be at right angles to the undersurface of the plane. All incidence and bracing wire pin centres must be trammelled for equal measurement.

Alternative Method of Erecting Complete Superstructure

Where suitable lifting tackle is available the complete superstructure, centre section, outer planes, interplane struts, petrol tanks, engine mountings, engines, and bracing wires can be assembled on the ground and lifted into position on the hull. If the superstructure is assembled on suitable trestles the wing floats can also be attached, but if assembly is carried out on the ground, or on low trestles, the floats must, of course, be attached subsequent to erection of the superstructure on the hull.

Check Rigging as Follows—

1. Incidence throughout.
2. Dihedral of top planes.
3. Dihedral of bottom planes.
4. Stagger and sweepback on centre section, if any.
5. Stagger and sweepback on outer main planes, if any.
6. Different dihedral of the top and bottom outer planes produces a backward sweepback of the bottom plane, compared with the top plane, measured at the outer struts.
7. Engine mounting for alignment.
8. Tail plane incidence with adjustment each way from normal position.

Final Check

The usual final check measurements for symmetry of the complete aircraft should be made.

These should include the following—

1. Sternpost to foot of front outer interplane struts.
2. Nose of hull to foot of front outer interplane struts.
3. Outer tips of tail plane front spar to centre line of hull just aft of the trailing edge of bottom centre plane, also to foot of front outer interplane struts.

Rigging of Float Undercarriage

The aircraft should be set up with fore and aft and transverse datum lines horizontal.

The longitudinal centre lines of each float must lie truly parallel with

AIRCRAFT TYPE _____
REGISTRATION MARK _____

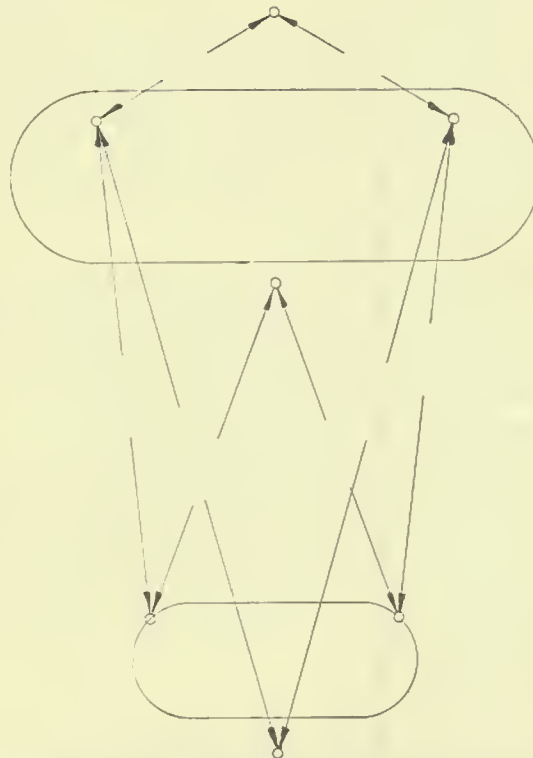

FIG. 44. DIAGONAL MEASUREMENTS OF ERECTED AIRCRAFT

the centre line of the aircraft and must be equi-distant from the aircraft's plane of symmetry. The datum line of each float must be at the correct inclination to the aircraft's fore and aft datum and the plumbed distance between an important item on a spar (or a formed-extension of the points

of attachment of the undercarriage to the fuselage) to a common point on each float must be equal.

The fore and aft horizontal distance between common points on each float and key position on the aircraft must be equal. The distance between a common point towards the bow of each float and a common point towards the stern of the other should be equal.

The individual floats should be checked to see that the dorsal or the centre of the top surface is plumb over the keel or centre of the planing bottom.

The particulars should be entered in a form similar to Fig. 44.

Water Rudders

Water rudders are sometimes provided for seaplanes, being usually operated by the rudder bar and situated on float seaplanes at the aft end

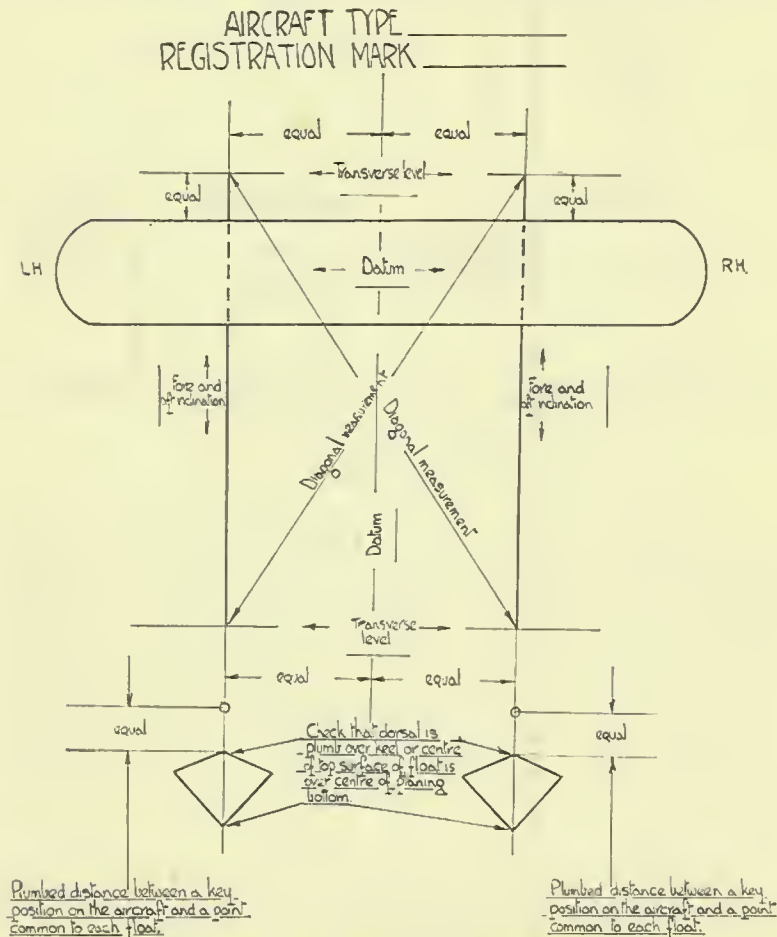

FIG. 45. SEAPLANE MAIN FLOAT RIGGING DIAGRAM

of the floats, in a similar position to that occupied by a normal ship's rudder. Water rudders are seldom used for boat seaplanes, mainly because all the control normally required is obtained from the engines, of which there are usually two or more. Water rudders are a normal part of amphibian aircraft.

14. GENERAL MAINTENANCE AND MINOR REPAIRS OF HULLS AND/OR FLOATS

Repairs of Hull and Floats

The treatment of a particular repair is very largely at the discretion of the repairer, and these notes are intended only as a guide. Every effort should be made to restore the damaged parts as nearly as possible to their original strength and condition, and the methods employed in building must follow closely the directions in manufacturers' handbooks.

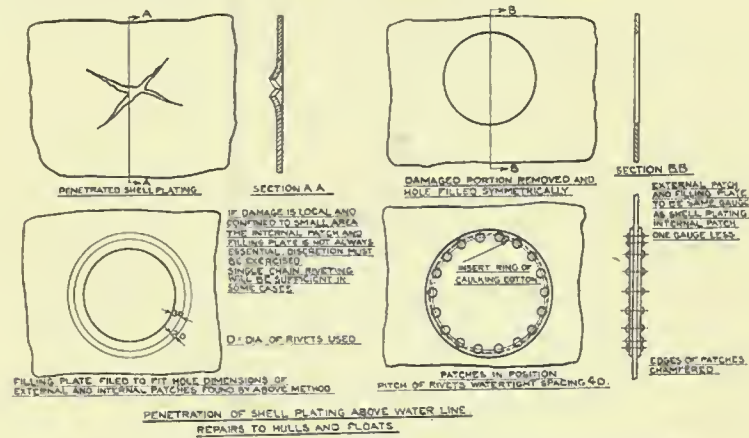

FIG. 46. REPAIRS TO HULLS AND FLOATS ABOVE WATERLINE

When repairs are carried out the plating, rivets, etc., must be to the same specification as the material being replaced; this is very important where the hull and/or floats are constructed of stainless steel, as electrolytic action takes place between various stainless steels. The size and spacing of the rivets should be the same as that found in similar parts of the structure. Patches must be riveted round the edges with the size and pitch of rivets used in the plate being patched. Rivet holes must be drilled, and the patch carefully closed to the plate with bolts before riveting is commenced. Rivets are best removed by cutting off the heads with a small cold chisel and light hammer and punching out the shank. Where the plating is perforated the jagged edges should be "faired up" or cut away, preferably to a square, oblong or circular shape, and a patch of similar (but, of course, larger) shape fitted and riveted outside (see Fig. 46).

If the repair is on a part of the structure with a pronounced curvature, the patch must be curved or beaten to shape so that it goes into position without being forced. The rivets must not be worked in consecutive order, but at intervals, otherwise the material will stretch and the rivet holes

(Figs. 46, 47, and 48 from A.P. 1147, by kind permission of the Controller, H.M.S.O.)

will not coincide. Where a very quick repair is necessary to under-water plating of a boat there is no need to cut out the damaged part. The piece used for patching must be large enough to lap over the part of the plate remaining fair. In making a quick repair, fix the patch by using small

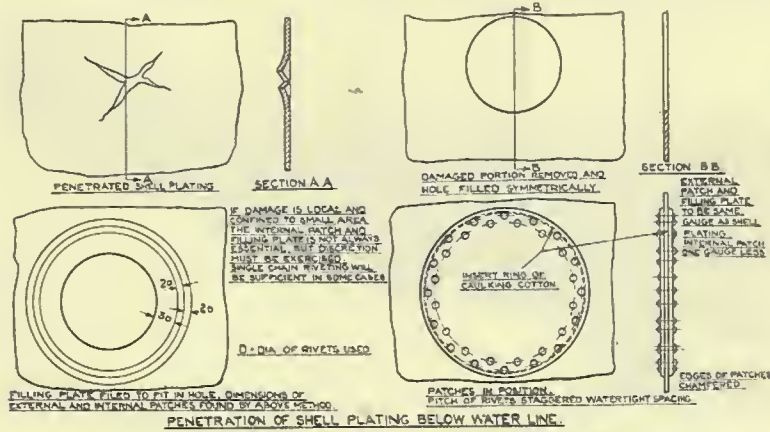

FIG. 47. REPAIRS TO HULLS AND FLOATS BELOW WATERLINE

bolts instead of rivets. Proper patching in accordance with Fig. 47 must take the place of this makeshift repair as soon as the aircraft base is reached.

Joggled Patch

Damage at a seam or butt insufficient to warrant the removal of two whole plates would normally be repaired by a joggled patch where facilities

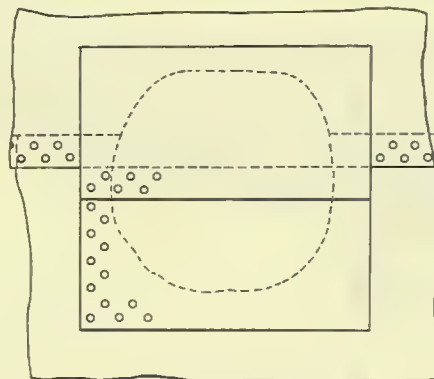

FIG. 48. JOGGLED PATCH

for joggling the plate do not exist; the difficulty in making a watertight joint where the patch crosses the leading edge of the seam may be overcome as shown in Fig. 48.

In this case two pieces are used, one butting against the edge of the outside plate and the other lapped over the first. If duralumin rivets are

used during repair work they must be heat-treated, before use, at the normalizing temperature (480–490° C.) and riveted up within 1 hour of treatment. Lower temperatures during heat treatment will render the rivets more liable to corrosion. Should a repair be carried out and no



FIG. 49. HULL PLATING BEFORE COMPLETION OF REPAIRS

approved protective covering be available, the parts should be treated with grease, until the proper coating can be applied.

Figs. 49 and 50 show a hull during and after plating repairs.

Note—Preservation of the structure's poise should always receive adequate attention. It will be seen that if old plates are taken off at



FIG. 50. SHOWING PLATING OF HULL AFTER REPAIRS

random dangerous distortion or even collapse of the structure may occur. Where more than one plate is taken off at a time, therefore, it should have been previously verified that the structure is well able to bear such a loss.

Test for Watertightness

HULL

After all repairs check all watertight seams; laps and collars are usually caulked with putty and white paint and cotton, but other approved

methods may be laid down in the manufacturer's handbook. A water test may be carried out as follows—

(a) Fill the hull with fresh water to the level of the waterline, and leave for a period of 1-1½ hours; then examine the exterior for leaks, and if any leaks are noted carefully mark same. The hull should then be emptied and the whole of the remaining plating and joints should be tested by spraying water on to all seams, etc., outside the hull, by the use of a hose pipe fitted with a small nozzle giving a fine jet of water at high pressure. Examine at the same time all joints, etc., inside the hull.

(b) If the hull is not filled with water, the whole of the plating and joints should be sprayed externally as already described in the latter part of paragraph (a).

FLOATS

During repairs all watertight seams, laps, collars, and bulkheads are usually caulked with putty and white paint, and, where joggled with cotton, each compartment is finally tested separately by filling with fresh water to a depth of 10-12 in. This is allowed to stand for 5-15 minutes, the keel, bulkheads, and keelson being examined. The float is then turned on to its side and the chines examined. After securing the watertight covers, again turn the float so that all remaining joints can be tested.

GENERAL

All laps and seams are tested by spraying the water into the other side of the lap or seam. Where leaks occur the joints should be caulked and re-tested; in the case of individual rivets leaking these should be replaced.

MAINTENANCE OF HULLS AND FLOATS

On no account must sea water be allowed to remain inside the hull. The interior should be carefully wiped out, particular attention being given to small crevices where water is liable to accumulate. The wing tip float inspection covers should be removed and any leakage water drained off by taking out the drain plugs. Deposits of salt must be cleaned off and wetted surfaces swabbed with fresh water and dried. Abrasions of the external and internal surfaces of hulls and floats must be first coated with an approved undercoat of paint, but this is not to be used over the whole surface on top of the original finishing coat. The deterioration of the top surface enamel will need close attention, and may necessitate the periodical application of a coat of finishing enamel. After this has been done two or three times, the whole of the paint work should be stripped and re-coated. The unlimited application of successive coats of finishing enamel would result in the cracking and flaking off of the thick coating of paint. Also, a large amount of weight would be added by each coat. The old paint should be removed by a suitable solvent such as "Nitro Mors," "Strip off," or any other approved paint remover. Light alloy hulls which are kept afloat for a long period will require special attention, i.e. when hauled up they should be scrubbed down and the bottom immediately cleaned to free weeds and barnacles, before these are allowed to dry on. This is especially necessary in the case of flying boats operating in tropical waters.

During launching and bringing the aircraft ashore it is necessary to take special precautions against damage to the hulls and floats, and for this purpose beach trolleys or a detachable chassis is used. A tail trolley is necessary in addition, when the latter form of chassis is used.

15. MARINE EQUIPMENT: DESCRIPTION AND MAINTENANCE

Mooring and Towing Gear

The gear sometimes takes the form of a main control bridle, painter, and towing bridle.

The main bridle is in two lengths connected by a shackle, the ends being attached to the bow and keel of the hull. The painter connected to the bridle shackle extends some distance to a second shackle. Tow rope and side lines are attached. The side lines run aft from the towing shackle to fittings on the lower centre section, and assist to counteract yawing during towing operations. This gear should always be checked during daily inspection.

BOAT HOOK

The purpose of the boat hook is for attaching a mooring line from the aircraft to any suitable object within reach. The hook to which the mooring line is attached is provided with a spring loaded tongue to prevent it becoming disengaged from the mooring when its haft is withdrawn.

The boat hook is normally stowed inside the hull at its forward end. An additional stowage is usually provided externally adjacent to the internal stowage.

Ground Anchors

The anchor is of a pattern similar to that used on small launches.

The flukes are detachable from the stock to enable it to be easily stowed.

The anchor, complete with approximately 6 fathoms of cable, is stowed as far forward in the hull bows as possible and is carried in order that the aircraft may be temporarily moored when a mishap has occurred or when no mooring facilities are available.

The anchor in some aircraft is cast and weighed unassisted by manpower, its cable being attached to the aircraft by helaying it on a mooring bollard situated at stem of hull. A small anchor cable drum is sometimes provided, to which the anchor cable is attached and led through a small fairlead in the hull bows. Facilities are provided on this drum for hauling or lowering the anchor.

Sea Anchor or Drogue

The purpose of the sea anchor or drogue is for checking the forward speed and drift of the aircraft and to allow it to ride steadily in a seaway.

In shape it is usually the frustrum of a cone, although alternative shapes are sometimes employed.

It is manufactured in the best quality white canvas and is strengthened at its larger end by a wire hoop, to which the canvas body is attached. At this end a rope loop is provided to attach a cable towing line which is secured to the aircraft, the towing line's length being governed by the type of aircraft to which it is fitted.

The towing wire should be oiled, wrapped with fabric following the "lay" of the cable, stretched and served with balloon cord; this gives additional protection against salt water corrosion.

Stowage is provided for the sea anchor or drogue in an easily accessible position either on the planes or in the hull.

Maintenance Notes

After use the drogues should be hung up and allowed to dry, and at the same time salt water should be removed from the cables and shackles before packing and placing in stowage positions. Stowages should be

checked, and when the drogues are not in use care must be taken that they are easily fastened. After renewal of cables great care must be taken

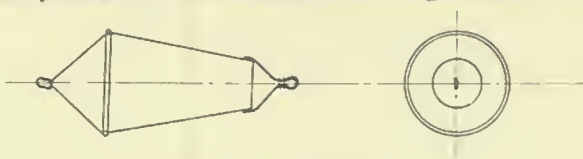

FIG. 51. DETAILS OF ANCHOR

to ensure that the towing wire is attached to the bridle, as cases have occurred where the wire has been fixed to the small end, thus rendering

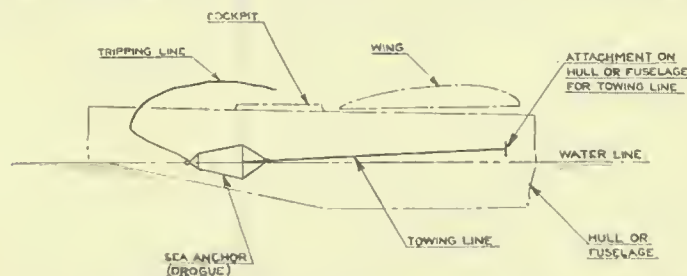

FIG. 52. RELATIVE POSITION OF ANCHOR TO AIRCRAFT WHEN IN USE

the drogues useless, which may result in serious damage or even loss of the aircraft. Therefore the complete system should always be checked.



FIG. 53. HAULING DROGUE ON BOARD AFTER AIRCRAFT HAS BEEN MADE FAST AT MOORINGS

Details of the anchor are shown in Fig. 51.

The anchor position relative to the aircraft when in use (see Fig. 52).

Fig. 53 shows drogue being hauled on board after aircraft has been made fast at moorings.

Bilge Pump

This pump as applied to aircraft is a plunger type of approximately 3 in. diameter bore and is provided with suction and discharge hoses for the purpose of clearing the hull bilges of wash.

Stowage is provided in the aircraft for the pump and hose when not in use.

The pump, which is portable, is provided with hinged footholds at its base, which are folded into the pump body when not in use.

The pump can be used at any suitable position in the hull, the suction hose being placed in the hull bilges and the discharge placed over the hull side.

CHAPTER IV
INSTRUMENTS

16. AIR SPEED INDICATORS

(Approved types: Mk. IVA and VB, Pioneer 354 and Koreect)

THE air speed indicator is an instrument for use on aircraft to show the speed at which the aircraft is travelling through the air. The instrument at present used consists of a differential pressure gauge mounted on the instrument board and a pressure head fitted outside the aircraft connected to the air speed indicator by tubing.

The principle of the instrument shown in diagrammatic form in Fig. 54 is that it records the difference between the wind pressure due to the passage of the aircraft through the air and the pressure of the surrounding still air.

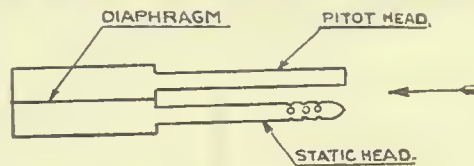

FIG. 54. AIR SPEED INDICATOR DIAGRAM

The Pressure Gauge (A.S.I.)

Of the two most common forms of construction, one consists of an airtight chamber divided into two compartments by means of a diaphragm. The pitot head is connected to one compartment and the static head to the other. Any change in the pressure in either compartment causes the movement of the diaphragm, which is recorded on the dial by means of a pointer. A disc with a spindle working in a guide is attached to the centre of the diaphragm; as the diaphragm moves the end of the spindle presses against a leaf spring which is deflected in proportion. The leaf spring actuates a bell crank lever, one arm of which projects through a slot in a metal plate pivoted on an axis parallel to that of the pointer spindle. At one end of this plate is a quadrant engaging a pinion on the spindle which carries the pointer. A hair spring is fitted to the pointer spindle to take up any backlash in the mechanism (see Fig. 55).

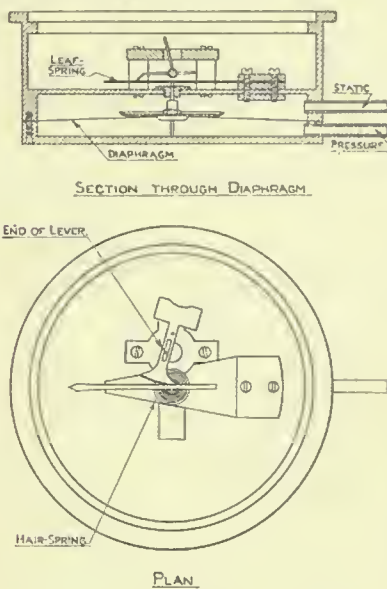

FIG. 55. DIAGRAM SHOWING CONSTRUCTION OF AIR SPEED INDICATOR GAUGE (DIAPHRAGM TYPE)

Fig. 56 shows a further type of air speed indicator which has a diaphragm box similar to an altimeter, the pressure pipe communicating with the inside of this elastic box. The pipe from the static side is led into the

(Figs. 54 and 55 from A.P. 1275, by kind permission of the Controller, H.M.S.O.)

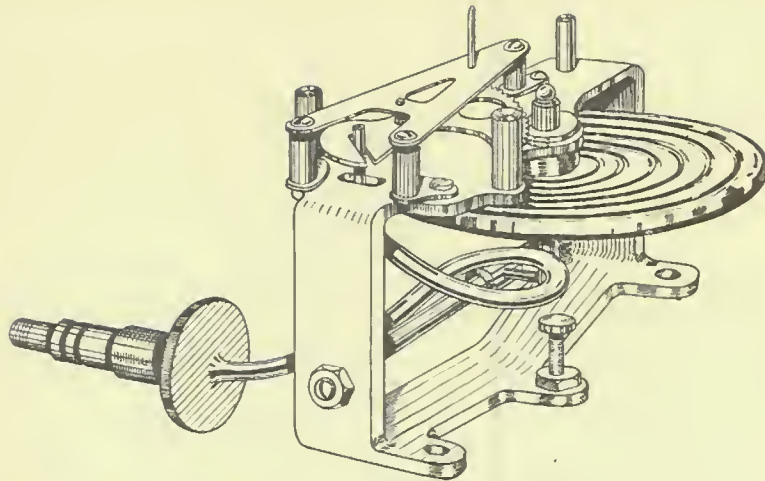

FIG. 56. SHOWING CONSTRUCTION OF AIR SPEED INDICATOR (CAPSULE TYPE)

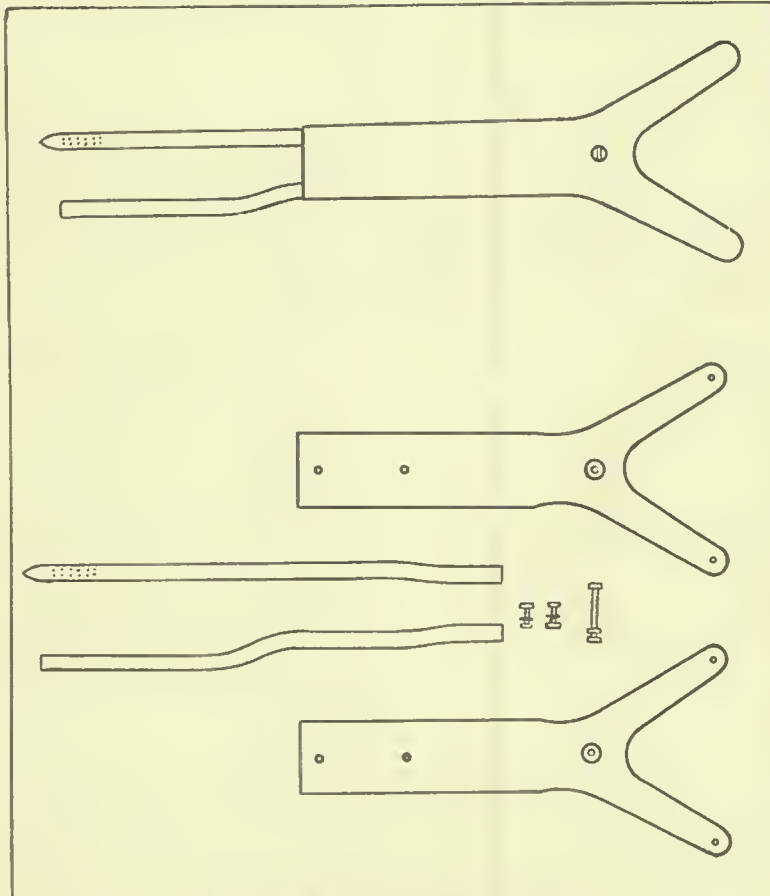

FIG. 57. MARK IVA PRESSURE HEAD

airtight case. The diaphragm box is held in a frame which also carries a transverse shaft having two short balanced arms mounted across it. The transverse shaft arms form a bell crank mechanism in which the two arms are considerably offset. One arm is coupled to the underside of the diaphragm or capsule, so that expansion or contraction of the latter results in rocking

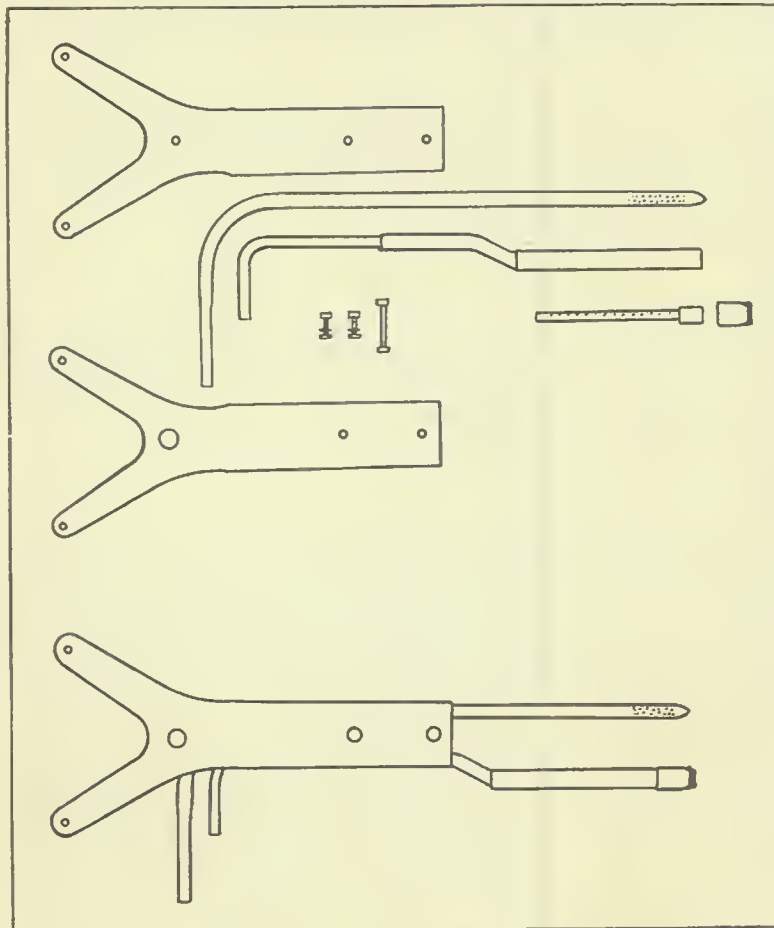

FIG. 58. MARK VA PRESSURE HEAD

the transverse shaft. The arm is cranked to pass through a hole in the top of the frame and engages in the slot of a toothed quadrant, meshing with the pinion of the pointer spindle. A hairspring is fitted to take up any backlash.

The Pressure Head. (Approved types: Mk. IVA and VA.)

The Mk. IVA pressure head (Fig. 57) consists of a static tube with a closed pointer, the forward portion of the tube being perforated with a series of small holes. The pressure tube is open at the end.

The Mk. VA pressure head (Fig. 58) is generally the same as the IVA,

except that the pressure pipe has within it a tube closed at the back but open at the front end and drilled on its upper surface with a number of small holes which communicate with the inside of the larger pipe. The inner tube is located in the outer by a brass nipple soldered at the open end. The tube is prevented from rotating by flats on the nipple and the outer pipe. "Top" is stamped on the nipple to ensure correct assembly with perforations uppermost. A screwed nipple cap with an airtight joint fixes the inner in the outer tube.

With this pressure head the static tube is the higher placed of the two and has "top" stamped on it. The head was designed for use in tropical countries when trouble due to choking of the ordinary pressure tube by insects, etc., was met with. Care should be taken to keep the inner tube clean of any accumulations and the perforations clear. See that the word "top" is right way up on replacement.

The brass cap should be tightened with the fingers only to prevent straining the immediate installation.

Piping

The piping from the pressure head is of light alloy on landplanes and non-corrosive material or copper on seaplanes. The tubing joints and connections are made by rubber tubing or otherwise low-pressure couplings.

Graduation Marking of Instruments

The indicators on land aircraft are graduated in miles per hour; on seaplanes they are graduated in knots.

Installation and Maintenance

Owing to disturbances in the air current due to the reaction of parts of the aircraft and the slipstream of the tractor airscrew it has been found by experience that the best position for the pressure head is in front of an outer strut. On monoplanes the usual position for the pressure head is on an extension forward from the leading edge, or on a downward extension (about one-quarter of the wing chord) below the plane. The position in both cases is out towards the wing tip, beyond the influence of the airscrew slipstream.

It is important that all pressure heads should face the direction of flight. When more than one indicator is required on large aircraft the gauges are coupled up in parallel to one pressure head. To check for correct functioning let air be blown lightly down the pressure tube and hold the pressure at different stages while noting the indicator pointer. Should the pressure fall back rapidly check all the joints and pipe lines. Cases have been known where failure has been caused by corrosion eating holes through the piping.

Inspect the pressure head for damage and see that the edge of the opening of the pressure tube is smooth and round, also that the small holes in the static tube are clear. The static system should be checked by clipping a rubber tube beyond the rearmost of the small holes and applying suction instead of blowing as in the case of the pressure side. The rubber tubing should in this case be so arranged as to allow a concentric space between it and the static tube.

Testing

The air speed indicator may be tested by connecting it up in parallel with another air speed indicator of known accuracy. Portable calibrators

(Figs. 59 and 60) are also available. These provide a portable standard against which the accuracy of air speed indicators may be checked. The scale is graduated to read direct air speeds. Air pressure is supplied to both the manometer and indicator under test, and comparison is made between the readings. The permissible tolerance is approximately ± 3 m.p.h.



FIG. 59. AIR SPEED INDICATOR UNDER TEST (READING M.P.H.)

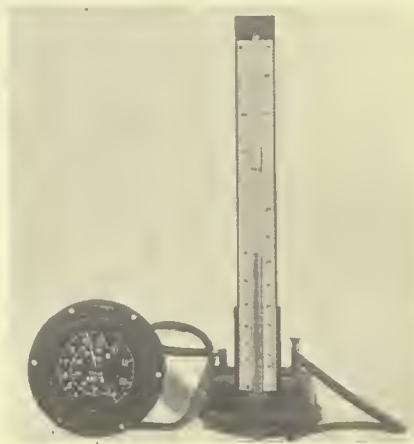

FIG. 60. AIR SPEED INDICATOR UNDER TEST (READING KNOTS)

17. ALTIMETER

(Approved types: Mk V, Mk VA, Mk VB)

Altimeters are instruments for indicating the height of the aircraft. These instruments are similar in construction to the aneroid barometer and measure the pressure of the atmosphere, but unlike the barometer, the dials are calibrated to read height direct. This height is, however, only approximate, as the accurate determination of height is not easy, necessitating an exact knowledge of air temperatures as well as pressures. The Mk. V series instruments are calibrated in accordance with the "Isothermal Law" (i.e. the temperature of the air is assumed to be constant at all heights).

The diaphragm box is round and flat with corrugated sides, airtight and from which air has been exhausted. One side of this box is connected with the base plate, and the other to the end of the leaf spring. A change of pressure causes the diaphragm to move, and the spring moves together with the diaphragm. This small movement is magnified by means of a long connecting lever, a bell crank lever, a chain, drum, and spindle. The pointer is attached to the spindle and a hairspring is fitted to overcome any back lash (see Fig. 61).

The pointer moves over a height scale on the dial. The dial is operated by a milled knob attached to a pinion, and before each flight the milled knob should be turned to set the zero on the dial in line with the pointer. When the altimeter is installed the dial should be as near vertical as possible with the milled knob at the bottom. The instrument should be mounted so as to be unaffected by vibration.

Testing

(Suitable apparatus: Mk. I portable type calibrator and a standard altimeter Mk. IIID.)

Altimeters are tested in a cylinder, the air being exhausted by means

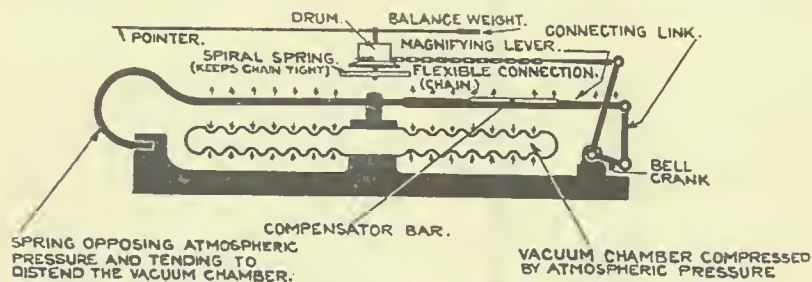

FIG. 61. ANEROID ALTIMETER

of a vacuum pump. The cylinder is fitted with guide slots, and the instrument to be tested is placed inside the chamber together with a standard altimeter Mk. IIID. Adjust the pointer on the altimeter until it corresponds to the standard gauge, then exhaust the air until the pointer on the standard gauge reads 1,000 ft., and so on at the rate of 1,000 ft. per minute, the readings on the altimeter under test being noted and compared with

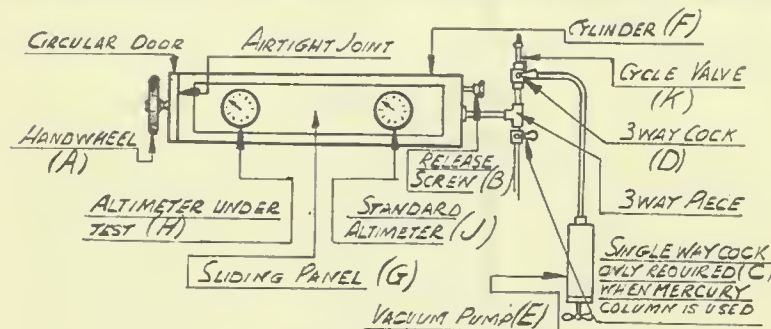

FIG. 62. DIAGRAM OF TESTING INSTALLATION FOR ANEROID ALTIMETER

the standard Mk. IIID. When this test is completed, allow air to enter the chamber through a release screw, thus increasing the pressure, and note the reading at each 1,000 ft. during descent.

The principle of the Mk. I portable type calibrator is shown in diagrammatic form in Fig. 61.

Sequence of Operation

1. Remove circular door by releasing hand wheel (A).
2. Tighten up release screw (B).
3. Close cock (C).
4. Turn cock (D) to couple pump (E) to cylinder (F).

(Fig. 61 from A.P. 1234, by kind permission of the Controller, H.M.S.O.)

5. Draw out sliding panel (*G*) and fit altimeter (*H*) and (*J*); at the same time set altimeter (*H*) to correspond with standard (*J*).
6. Replace panel and close door by hand wheel (*A*).
7. If standard instrument is below zero, slightly exhaust cylinder (*F*) by pump (*E*).
8. If standard instrument is above zero attach small pump to cycle valve (*K*) and pump slight positive pressure into cylinder.
9. Close cock (*D*) and proceed with test already described.

18. TURN INDICATOR

Approved types for civil aircraft are—

Reid.	Reid-Sigrist.
Sperry.	S. G. Brown Type E.
Schilovsky-Cooke.	S. G. Brown Venturi Type A.
Mechanism, Ltd.	Mark I.A.
Pioneer No. 385.	Mark I.B.

A brief description follows of the latest type turn indicator—Mk. I (Reid and Sigrist). This indicator employs an air-driven gyroscope

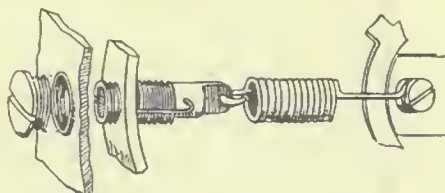

FIG. 63. SPIRAL SPRING AND SCREW FOR ADJUSTING TURN INDICATOR SENSITIVITY

mounted in a horizontal gimbal ring, the axis of the gyroscope being athwart the aircraft and the axis of the gimbal ring fore and aft. When the aircraft turns, the movement corresponds to rotation of the instrument in a horizontal plane, and a precessing torque is applied to the gimbal ring to turn. The gimbal ring, being spring controlled, comes to rest in a position of equilibrium when the precessing torque balances the tension in the spring. The movement of the gimbal ring, suitably damped, is indicated by means of a pointer on the scale in the front of the instrument. A second pointer on the scale, giving a cross-level indication, is actuated through a gearing device by a pendulum, the pointer moving in the direction of tilt.

A spiral spring, the tension of which may be adjusted, is attached between the gimbal and spider (see Fig. 63) and serves to control the sensitivity of the instrument.

Access to the adjusting screw is obtained through a hole drilled in the side of the case. Insert a screwdriver into the hole and give the inside screw a slight turn anti-clockwise, according to whether less or more sensitivity is required. One complete turn in this direction is usually sufficient.

Installation of Instrument in Aircraft

It is essential to have the instrument correctly fitted to the pilot's dashboard. The aircraft should be in the flying level position and the

top needle on the zero mark (see Fig. 64) before placing the screws in position.

Fit the venturi (see Fig. 65) in the slipstream as near the dashboard as possible, and connect to the instrument, using light alloy metal tubing

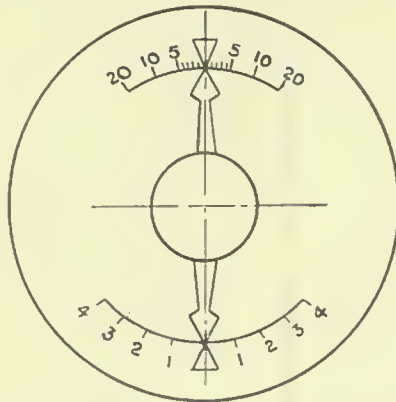

FIG. 64. TOP NEEDLE WITH RELATION TO ZERO MARK, TURN INDICATOR

and low-pressure metal couplings, or a piece of pressure rubber tubing. Care should be taken to fit the venturi in the best position. If the aircraft is fitted with an air-cooled engine, fit on or near the exhaust pipe; on water-cooled engines the venturi can be fitted behind the radiator, so that the warmth from the engine will prevent the tube becoming frozen, no matter

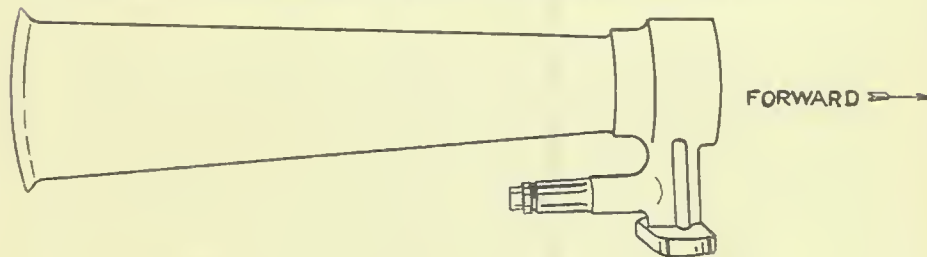

FIG. 65. INSTALLATION OF TURN INDICATOR VENTURI

at what altitude the aircraft is flown. When the venturi is in position the small end must be in front, facing the line of flight.

The Gyro Rotor Unit (Reid and Sigrist)

The principle of the air-driven turn indicator is shown in Fig. 66.

(a) The position of the unit when the instrument is running normally, that is, when the aeroplane is flying a straight course.

(b) The position of the different components when the gyro needle is indicating a rate of turn to the left, the action being as follows—

The gyro is spun by the inlet of air through the jet and precesses clockwise on the end bearings, the amount of precession being controlled by

the spring. The needle is moved by the gearing, so that its indication is twice the angular amount of the gyro precession.

(c) The position of the unit when the gyro needle is indicating a turn to the right.

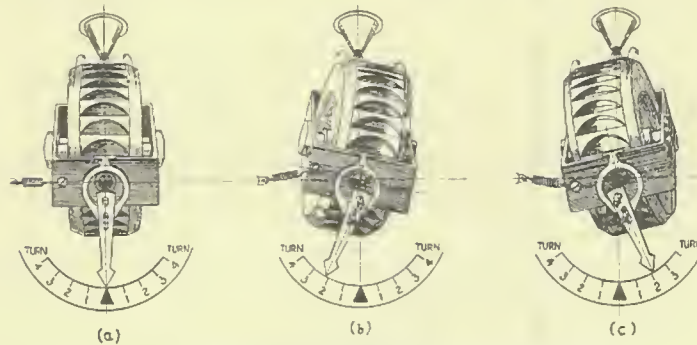

FIG. 66. TURN INDICATOR GYRO ROTOR UNIT

Maintenance

The instrument should be examined occasionally to see that the air connection is airtight, and that the nozzle of the case is screwed up so that no leaks occur. Clean the dust cap, and remove the top cap nozzle and the double gauze filters.

To do this the three small screws in the top cap of the inlet nozzle should be removed, and the double gauze filters taken out, cleaned, and replaced. At the same time the inside of the tube should be cleaned and the neck examined to see that no dust from the engine has accumulated around it. No attempt should be made to dismantle this instrument. If a fault develops, the instrument should be returned to the makers for overhaul.

19. COMPASS INSTALLATION IN AIRCRAFT, AND ADJUSTMENT

- I. Inspection before installation.
- II. During installation.
- III. Coefficient A.
- IV. Coefficient B.
- V. Coefficient C.
- VI. Sequence of swinging.
- VII. After adjustment.

(I) Inspection Before Installation

(a) Inspect compass for damage in transit.

(b) Inspect for freedom from pivot friction. The compass should be in a level position; note the reading: by the use of a magnet deflect the compass needle through about 10° , remove the magnet and if the compass magnet system returns to its original position when the bowl is tapped with the finger the compass may be considered free from pivot friction.

(c) Inspect for freedom from discoloration of the card, bowl, liquid, or window. The compass must be sufficiently clear to enable the pilot to read under normal flying conditions.

(d) Inspect the anti-vibrational devices; moving parts must be inspected for condition.

(e) See that the bowl is completely filled with approved liquid, and if even small bubbles appear add more of the approved liquid until all bubbles disappear.

II. During Installation

(a) The compass should be handled carefully and must not be subjected to shocks.

(b) Mountings should be of non-magnetic material and securing screws should also be of non-ferrous or other non-magnetic metal.

(c) With the aircraft in rigging position the compass should be horizontal (or vertical according to type).

(d) The lubber line must be forward and be parallel with the fore and aft centre line of the aircraft.

(e) The corrector box must be fitted below the centre of the compass with one set of magnet holes fore and aft.

(f) All removable and fixed equipment must be in the correct position before swinging the aircraft for compass adjustment.

ANALYSIS OF DEVIATION

III. Coefficient A

All the iron and steel parts and equipment of an aircraft are magnetic to some extent, and each individual part in the neighbourhood of a compass tends to cause deviation. It would be impossible to compensate separately for the effect of each individual part, but fortunately this is not necessary. All the possible magnetic effects in an aircraft can be resolved into five distinct types which are called the approximate coefficients, and are distinguished by the five capital letters *A* to *E*. The deviation coefficients *D* and *E* will be ignored here as no provision is made in any modern compass for corrections. It is necessary to know how to calculate the coefficients and how to correct for them. The necessary rules are given below, the calculations being based on the following deviation table—

Magnet		Compass	Deviation
N.	(0°) . . .	350°	+ 10° (E.)
N.E.	(45°) . . .	39°	+ 6° (E.)
E.	(90°) . . .	91°	- 1° (W.)
S.E.	(135°) . . .	140°	- 5° (W.)
S.	(180°) . . .	186°	- 6° (W.)
S.W.	(225°) . . .	228°	- 3° (W.)
W.	(270°) . . .	261°	+ 9° (E.)
N.W.	(315°) . . .	301°	+ 14° (E.)

The effect of coefficient *A* is to cause the same deviation on all courses. Coefficient *A* may be set up by—

- (i) An unusual distribution of soft iron in the craft:
- (ii) The incorrect mounting of the compass (lubber line slewed out of its correct position); or
- (iii) The incorrect mounting of the card upon the magnet system (card error).

In the first case the coefficient is known as "real A " and in the other two "apparent A ." Coefficient A is calculated by the following formula

$$A = \frac{\text{Sum of 8 deviations on N. N.E. E. S.E. S. S.W. W. N.W.}}{8}$$

To calculate A from the deviation given above

$$A = \frac{+10 + 6 - 1 - 5 - 6 - 3 + 9 + 14}{8} = \frac{+39 - 15}{8} = \frac{+24}{8} = +3^\circ$$

Whether A be real or apparent the method of correction is the same. To correct $+A$, turn the compass bowl round clockwise. To correct $-A$, turn the compass bowl round anti-clockwise. Hence, since the value of A in the example is $+3^\circ$, the method of correcting would be to loosen the bolts holding the compass, turn it 3° clockwise (reading the 3° from the compass) and then secure the instrument again.

IV. Coefficient B

This may be considered as due to an imaginary magnet lying in the fore and aft line of the machine. The maximum effects are found on magnetic east and west.

Coefficient B is obtained from the formula

$$B = \frac{\text{Deviation on east} - \text{deviation on west}}{2}$$

To calculate B from the example—

$$B = \frac{-1 - 9}{2} = \frac{-10}{2} = -5^\circ$$

Notice that the sign of deviation on west is changed from $+$ to $-$. The sign of a deviation must always be changed when the sign ($-$) precedes the deviation in the formula (algebraic subtraction). The rules for correcting B are—

To correct $+B$, use fore and aft magnets with red poles forward.

To correct $-B$, use fore and aft magnets with blue poles forward.

Correction is carried out when the craft is heading east or west.

To correct for B of -5° , insert magnets in the fore and aft tubes in the corrector box, blue poles forward, until the compass reading changes by 5° as nearly as possible.

V. Coefficient C

The effect of this is similar to that of a magnet lying athwartships in the aircraft. The maximum effects are found on magnetic north and south.

The formula for calculating coefficient C is

$$C = \frac{\text{Deviation on north} - \text{deviation on south}}{2}$$

To calculate C from the example

$$C = \frac{+10 + 6}{2} - \frac{+16}{2} = +8^\circ$$

The rules for correcting for coefficient C are—

To correct $+C$, use athwartships magnets with red poles to starboard.

To correct $-C$, use athwartships magnets with blue poles to starboard.

The correction is carried out when the aircraft is heading north or south. The correction in the example would consist of inserting magnets in the athwartships tubes with red poles to starboard until the compass reading changed by 8°.



FIG. 67. P-4 COMPASS WITH CORRECTOR BOX DETACHED SHOWING MAGNETS PARTIALLY WITHDRAWN

VI. Sequence

Adopt a definite sequence when swinging any aircraft. A sequence is given here which may be simply followed. If more than one compass is fitted in the aircraft corrections to all compasses must be made before the aircraft is moved.

- (a) Place the aircraft on magnetic N. Align it carefully; put the aircraft and its controls in flying position. Enter the compass reading in log book.
- (b) Place the aircraft on E. Enter compass reading.
- (c) Place the aircraft on S. Enter compass reading.
- (d) Calculate and correct for coefficient *C*.

Calculations of coefficients and corrections made.

To calculate coefficient *C*.
 Deviation on N. = - 3°; on S = + 5°.
 Then $C = \frac{-3 - 5}{2} = -4°$.

To correct for coefficient *C*.
 Insert magnets athwartships with blue pole to starboard until compass reading changes 4°—i.e. until compass reads 179°.

VI. Sequence—(contd.)

- (e) Enter corrected reading on S.
 (f) Place the aircraft on W. Enter compass reading.
 (g) Calculate and correct for coefficient B.

To calculate coefficient B.

Deviation on E. = + 6; on W. = - 7.

$$\text{Then } B = \frac{+ 6 + 7}{2} = + 6\frac{1}{2}.$$

To correct for coefficient B. Insert magnets fore and aft with red poles forward until compass reading changes by $6\frac{1}{2}^\circ$. Suppose the nearest to this obtainable is 6° , then compass will read 271.

- (h) Enter correct reading on W.
 (i) Place the aircraft on N.W. Enter corrected reading.
 (j) Place the aircraft on N. Enter corrected reading.
 (k) Place the aircraft on N.E. Enter corrected reading.
 (l) Place the aircraft on E. Enter corrected reading.
 (m) Place the aircraft on S.E. Enter corrected reading.
 (n) Place the aircraft on S.W. Enter corrected reading.
 (o) Calculate coefficient A from corrected readings and correct for it if necessary.

Calculations of coefficients and corrections made.

To calculate coefficient A.

Deviations on the eight cardinal and quadrantal points after correction are—

+ 1, 0, 0, 0, + 1, - 1, - 1, - 1,

Then $A = \frac{+ 2 - 3}{8} = - \frac{1}{8}^\circ$ which is too small to attempt to correct.

EXAMPLE OF PARTICULARS ON COMPASS CARD

Adjustments made at . . . Southampton Aerodrome.
 Date of Adjustment . . . 17/11/33.
 Type of Aeroplane . . . "Goodflyer."
 Registration of Aeroplane . . . G-OXYZ.
 Type of Compass . . . P.4.
 Number of Compass . . . 8135.A.

	First Reading	Corrected Reading	Number and Disposition of Adjusting Magnets
N. (0°) . . .	3 (a)	359 (j)	1 magnet 2/32 red to port.
N.E. (45°) . . .		45 (k)	
E. (90°) . . .	84 (b)	90 (l)	2 magnets 2/32 red forward.
S.E. (135°) . . .		135 (m)	
S. (180°) . . .	175 (c)	179 (e)	
S.W. (225°) . . .		226 (n)	
W. (270°) . . .	277 (f)	271 (h)	
N.W. (315°) . . .		316 (i)	

Adjustment made and Deviation Card fitted by—

Signature
Remarks

JOHN BROWN, G.E., No. A. 125.
Compass liquid slightly discoloured.

VII. After Adjustment of Compass

- (a) Fasten the corrector box covers securely.
- (b) Fill in a deviation card (both sides) for each compass in the manner shown in the above example and mount it near the appropriate compass.

Ascertaining Deviations by Landing Compass (Landplanes)

Any aircraft can be swung as accurately by landing compass alone as by means of a swinging base (and in the case of large machines often more quickly). The aircraft should be set up in the open, at least 40 yards away from any considerable masses of iron, such as hangars, railway lines, etc., or 150 yards from an electric or W/T generating station, and the site chosen should be free from local magnetic effects.

Plumb lines should be suspended from the centre of the nose of the aircraft and the centre of the stern, and the landing compass should be set up in line with these and approximately 40 ft. in the rear of the aircraft. By sighting carefully through the slot and hair line of the landing compass on to the suspended plumb lines the correct magnetic heading of the aircraft can be read on the landing compass through the prism fitted thereto. The difference between this reading and that shown by the aircraft compass indicates the amount of error in the latter (i.e. the deviation) on any particular bearing. Successive readings are taken by swinging the aircraft about a fixed pivot point and by moving the landing compass round at a fixed radius from the same point, lining up always with the two plumb lines. It is not necessary to line up the aircraft "dead on" the desired bearing. A maximum error of 4° is permissible provided the error as shown by the bearing compass is added to or subtracted from the aircraft compass reading as necessary in order to deduce what reading the latter compass would have given if the aircraft had been aligned accurately. For example, if the aircraft compass shows 85° when the landing compass shows 88° it may be assumed that the aircraft compass would have shown 87° when the aircraft was correctly aligned on the 90° bearing. The method of correcting errors in the aircraft compass has already been dealt with.

Swinging an Aircraft Afloat

As a general rule the compass of an aircraft should not be corrected when it is afloat, as even under the most favourable conditions the degree of accuracy easily to be obtained from swinging ashore can scarcely be obtained. It is occasionally necessary or convenient to check the deviations while the aircraft is afloat, and of the various methods two will be briefly described.

The swinging is normally carried out while the aircraft is moored to a buoy. The essential problem is to determine the correct magnetic course of the aircraft at a given moment. One method is to take bearings of a distant object, preferably by bearing compass or from a bearing plate. An object should be selected at a suitable distance and its magnetic bearing from the buoy should be determined from a chart.

As a rough guide it may be mentioned that if the selected object be 3 miles distant from the buoy and the aircraft can move round a circle of 20 yards diameter, the maximum change of bearing due to alteration of the position of the aircraft will be of the order of $\frac{1}{4}^\circ$. Suppose the object selected be a lighthouse—*L* in Fig. 68—and the magnetic bearing of *L* from the buoy *B* is 30° . Then suppose that a bearing of *L* is found to be 34° by bearing compass from the aircraft at a moment when the course of the aircraft, by the bearing compass, is 70° . If *C* be the bearing compass, it is seen that the direction *CL* is given as 34° by the instrument

when actually its direction is 30° . It follows that a deviation of -4° exists, and this is the deviation on a course of 70° by compass. Hence, the magnetic course of the aircraft when the bearing was taken was 66° . It should be noticed that, if MM_1 represent the magnetic meridian, the bearing compass measures the angle MCL (plus or minus the angle of deviation), according to whether the deviation is westerly or easterly.

Considering now the use of a bearing plate, suppose P in Fig. 69 represents the bearing plate, and C the pilot's compass. The bearing plate must be fixed in the aircraft so that its lubber line lies in or parallel to the centre line of the aircraft, and it must be clamped with zero registering against the forward lubber line. Readings should be taken from the fore-sight of the instrument.

Suppose the bearing of L is found to be 324° and simultaneously the course by compass is 70° . If CPB be the centre line of the aircraft, the compass measures (inaccurately if there be any deviation) angle MCB



FIG. 68. SWINGING AN AIRCRAFT Afloat BY BEARING COMPASS



FIG. 69. SWINGING AN AIRCRAFT Afloat BY BEARING PLATE

The bearing plate measures angle BPL accurately. Then the sum of these angles (subtracting 360° from the sum if necessary) is the bearing of L from the aircraft by compass; $324^\circ - 70^\circ = 394^\circ$; $394^\circ - 360^\circ = 34^\circ$. As the correct magnetic bearing is 30° , there is a deviation of -4° on a compass course of 70° , or a magnetic course of 66° . Thus, the same result can be obtained from a bearing plate and steering compass as from a bearing compass.

It may happen that it is not convenient to take bearings in the manner outlined above. An alternative method is to mount a landing compass ashore on a site free from local magnetic fields and simultaneously to take bearings of the bearing compass or bearing plate in the aircraft from the landing compass and of the landing compass from the aircraft. It should be obvious from consideration of Figs. 68 and 69 that if L be supposed to represent a landing compass, and the bearing of the aircraft was 210° from the landing compass, then by taking the reciprocal of 210° (i.e. 30°) as the correct magnetic bearing of L from the aircraft the deviation can be obtained.

How in practice to swing an aircraft afloat can scarcely be usefully laid down, as so many various circumstances arise which may prohibit the adoption of any particular method. The vagaries of tide and wind, the number of the crew and amount of time available all require consideration. A few general remarks, however, may be made. If a motor-boat is available it will provide a convenient way of turning the aircraft round the buoy. In very favourable conditions, it may be possible to hold the aircraft steady on a particular course for a short time; when these

conditions obtain, the aircraft may be headed approximately on a cardinal or quadrantal point by reference to one of its own compasses. Usually, however, it will not be possible to hold the aircraft steady on any course for an appreciable time. It is then advisable to take a large number of bearings—say, one for every 12° or 15° of alteration of the aircraft's course. A curve should be plotted for the results obtained and a deviation card

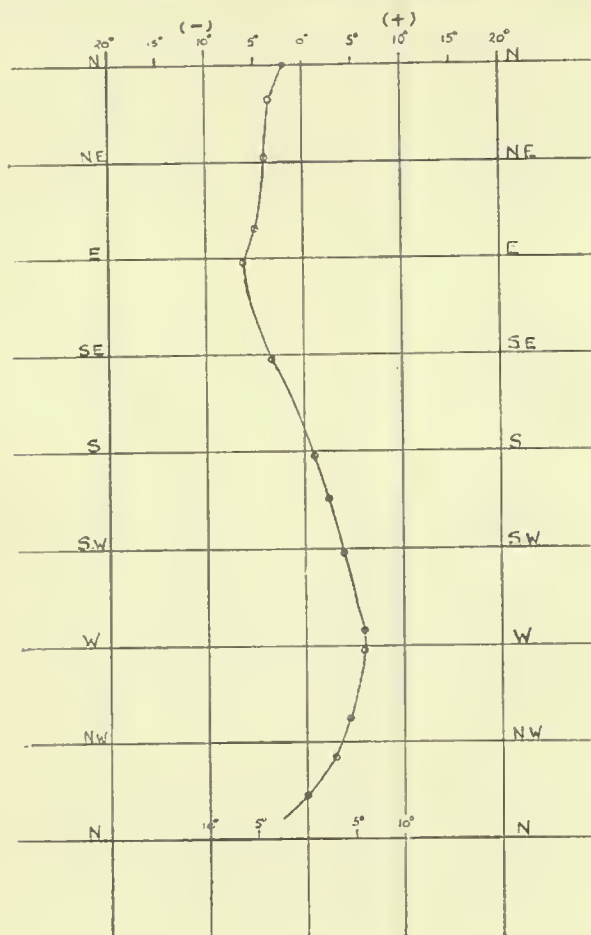

FIG. 70. CURVE OF COURSES

filled up from the curve. When it is necessary to take bearings, etc., as the aircraft is moving—even though the movement is slow—it is essential to good results that all observations be taken at the same time. Thus, suppose the bearing of a distant object be taken by bearing compass, one observer will be required to read the bearing and another the course from the bearing compass, while one observer is stationed at each of the other compasses in the aircraft. As the bearing is taken a pre-arranged signal should be given, all observations taken at once and immediately noted

down. If reciprocal bearings of a landing compass are being used, a clear code of signals between the shore and the aircraft must be devised.

The results of an actual swing of an aircraft afloat are now given in full. The aircraft was swung in a tidal river under adverse weather conditions by an experienced compass adjuster. Mist prevented observations of a distant object and no bearing compass was available. A prepared form was used as given in the following table.

	(1) Course by Pilot's Compass	(2) Bearing by Bearing Plate	(3) Sum of Cols. (1) and (2)	(4) Landing Compass Reciprocal	(5) Deviation
(274)	268	48	316	322	+ 6
(296)	291	26	317	322	+ 5
(321)	318	2	320	323	+ 3
(332)	332	354	(686) 326	326	0
(352)	355	336	(691) 331	328	- 3
(16½)	20	308½	328½	325	- 3½
(44)	48	282	330	326	- 4
(78)	83	249	332	327	- 5
(94)	100	233	333	327	- 6
(136)	139	189	328	325	- 3
(181)	180	141	321	322	+ 1
(207½)	205	113½	318½	321	+ 2½
(229)	225	91	316	320	+ 4
(264)	258	60	318	324	+ 6

The sum of Cols. (1) and (2) gives the equivalent to the bearing of the landing compass taken from the pilot's compass in the aircraft. Column (5) shows the deviation for the courses by compass in Col. (1). The magnetic courses corresponding to these compass courses were obtained; these are given in brackets on the left of the form. The curve shown in Fig. 70 was then plotted and the entry on the deviation card made as follows—

For Magnetic Course	Steer by Compass
N. 0	2°
N.E. 45	49°
E. 90	96°
S.E. 135	138°
S. 180	179°
S.W. 225	221°
W. 270	264°
N.W. 315	312°

(Certain of the text and data appearing on pages 64-71 have been extracted from A.P. 1234, by kind permission of the Controller, H.M.S.O.).

CHAPTER V
GENERAL SERVICE ELECTRICAL INSTALLATION INCLUDING
CONTINUITY AND INSULATION TESTS

20. THE GENERATOR

AIRCRAFT generators comprise various types of dynamic electric machines which, although of small output, are highly specialized in their characteristics and represent the latest development of light-weight design and manufacture. The generator is usually arranged for windmill (as here first considered) or sometimes for engine, drive (as secondly described).

Air-driven Generator

A typical air-driven aircraft generator (bi-polar type) complete with cable plug (see Fig. 71) is here described. It is direct current shunt wound for an output of 500 watts at 12 to 14 volts D.C. when running at a speed of 4,500 r.p.m.

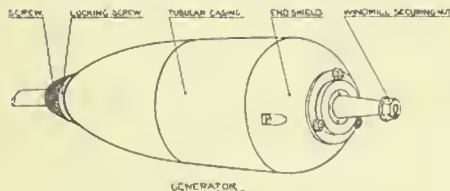

FIG. 71. GENERATOR

The body of the generator consists of an aluminium external tubular casing, with the field yoke fitted inside. The poles are formed integrally with the field yoke which is built up of laminated stampings. The field coils are

laid round the pole pieces before the field is fitted into the external casing, the coil overhang being taped up and varnished.

The aluminium end shield incorporates the front ball bearing which is designed to take the windmill thrust. The bearing is protected in front by a steel washer and an internal watertight gland, a second washer closing the bearing housing inside the end shield. Three screws are provided to bolt the two washers together and also secure the bearing to the end shield; the latter is fixed to the body of the generator by two bolts which pass through clearance holes in the field laminations and screw into the rear portion of the aluminium casing, the arrangement being such that the complete generator armature is withdrawn together with the front end shield. The forward end of the armature shaft is tapered to receive the windmill which is secured by a hexagon nut.

The armature core is built up of laminations and has twelve semi-closed slots in which the armature coils are laid, the slots being closed by fibre wedges which are driven in to secure the windings against centrifugal stresses. For the same reason, the end connectors and coil-overhangs are each bound with a layer of fine piano wire suitably insulated so as to prevent damage to the armature coil insulation.

The commutator is located at the rear end of the generator and has 36 segments. The rear portion of the generator, with spinning removed, is shown in Fig. 72.

The brush holders consist of two aluminium bridge pieces, which are secured to the bearing bracket by two bolts and are insulated from the brackets by flanged ebonite bushes through which the bolts are passed,

the flanged portions being on the brackets, while the nuts are insulated from the bridge pieces by mica washers. Two carbon brushes of rectangular cross section are mounted in each brush holder, the flexible leads being attached to the upper portion of each brush, which is copper-plated. Each brush is held in firm contact with the commutator by means of a pivoted arm, the extremity of which bears on the top of the brush, the bearing pressure being provided by small compression springs. The rear end of the generator is enclosed and protected by an aluminium spinning of streamline shape. The rear journal bearing is housed in the boss, which is formed between and cast integrally with two channel section arms forming an extension of the generator casing as shown in Fig. 71 above. A shoulder is formed at the rear end of the boss extension, the extremity being threaded to receive a locking screw. The end spinning fits over the threaded portion and is clamped between the shoulder on the boss and the locking screw. The connections to the generator are led in through a

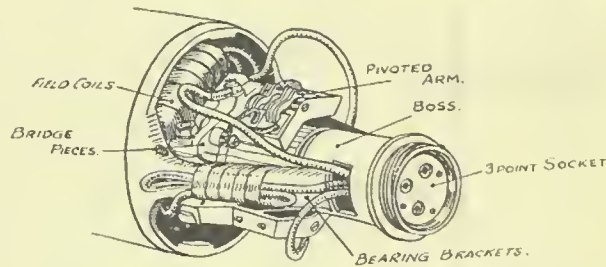

FIG. 72. GENERATOR WITH REAR SPINNING REMOVED

3-point plug and socket connection which is housed in the extreme aft portion of the generator.

The threaded portion of the boss is drilled and threaded internally, the 3-point socket being fitted and retained in the boss by a locking ring. The connections to the socket are soldered to lugs brought through the back of the socket, connecting up being carried out before the socket is fitted: the 3-point plug is retained in position in the socket by a knurled screw which engages in the internally threaded portion of the boss.

The internal leads are brought out from the back of the socket through a rectangular aperture cut in the boss as shown. One lead is connected to each brush holder and the third permanently connected to the generator field. The leads are identified by coloured braiding, the colour for the lead to the positive brushes being yellow, the negative blue, and the field slate. The corresponding connections on the plug and socket are identified by sunken marks of yellow, blue, and slate.

The wiring diagram of the generator is shown in Fig. 73. The generator operates in conjunction with a voltage box. The external generator leads are connected to the yellow, blue, and slate terminals on the control box, a suitable resistance or field shunt being connected in parallel with the generator field as shown in diagram (Fig. 74).

When a 12-volt accumulator is charged from such a generator as here described, in conjunction with a voltage control box, the battery will be charged on the "constant voltage system," therefore the initial charging current when the battery is discharged may be three or four times the normal charging rate for the particular battery in use. This heavy current

only continues for a short time, however, and will not damage the accumulator. The charging current will fall steadily as the accumulator becomes charged, being practically zero when the fully charged state is reached.

Aircraft generators are designed with a minimum of copper and iron in order to reduce weight, and the temperature rise on continuous load of such machines is thereby much greater than in normal generator practice.

The reduction in weight output ratio is rendered possible by the extremely favourable conditions of cooling when the generator runs in the unobstructed slipstream of the aircraft's airscrew. If an aircraft generator is run on load on the ground for a lengthy period it will tend to overheat unless provision is made for cooling—the machine should therefore be run on the ground, with reduced load or cooled with a suitable air blast.

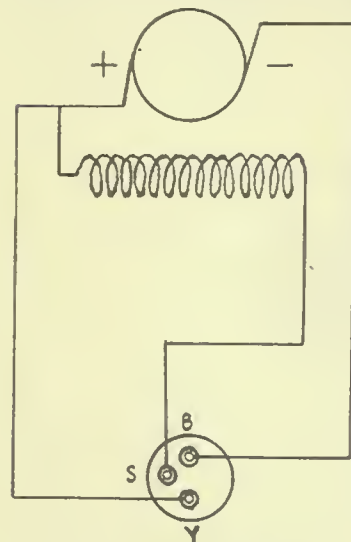

FIG. 73. GENERATOR WIRING DIAGRAM

Generators are manufactured to such specifications as will secure interchangeability of parts and give the required performance. In general, the generator is required to give a continuous output at full rating. In certain cases the generator is designed to take full advantage of the slipstream for cooling purposes, and the load run is then limited by the specification to half an hour. The normal fall of current due to temperature rise is compensated for by adjustment of the field regulator to maintain constant load. On conclusion of the load run the commutator is carefully examined. Any generator of which the commutator shows signs of pitting is rejected. Blaekening of the commutator is slight and even all round the periphery; regularly spaced blaekened segments alternating with bright segments are indicative of incorrect adjustment of the brushes or inherent bad commutation.

An overload 25 per cent in excess of the usual full load is customarily imposed.

The specification limits the speed at which the full output is obtained. "Inherent regulation" is usually expressed as a percentage of the rated load voltage and is obtained by observing the rise in voltage when the load changes from rated output (at rated voltage) to no load, at constant speed and without any external adjustment of the exciting circuit.

In the case of L.T. generators, as here described, all electrical parts must withstand the application of 220 volts A.C. between them and earth for a period of 1 min.

The test for insulation is made with a 500 volt megger immediately after the load run while the generator is hot; a lower value than 2 megohms is not accepted.

The limit for temperature rise above room temperatures is usually about 78° C. for low voltage generators. A telephone test for commutator ripple is made; such comparative tests often disclose defects such as incipient short circuits in the armature coils, defective soldering, etc.

Wherever possible a check test is made with the generator operating with its associated equipment (e.g. voltage control box, etc.).

The faults most frequently met with in generators, and the methods of testing and correcting, are—

Incorrect marking of the output plugs or socket, leading to cross connections when coupled to an external circuit: A test is made with the generator coupled to its load by means of the actual plugs provided.

Poor commutation leading to failure to excite, or, sparking under load. The commutator must be dead true both before and after test, the mica undercut (if so applicable), the brushes correctly bedded and free in their holders, and the whole armature perfectly balanced both statically and dynamically. It must be seen that the proper grade of brush is fitted and that the brush gear is in correct angular position and is truly rigid.

The driving end of the armature shaft is generally turned to a standard taper or otherwise adapted to carry a standard windmill, all mechanical dimensions at this point being carefully checked to ensure interchangeability.

Defective ball bearings: it sometimes happens that the race or its housing is of incorrect dimension and gives rise to unusual vibration and noise at full speed running.

End play is also checked and the radial tightness of the bearing proper should be such that there is no appreciable shake at working temperature conditions.

Armature whip is sometimes met with and is revealed by the armature rubbing against the pole pieces. This rubbing is often very difficult to detect, as it may only develop under full load and causes little more trouble than an increased rise of temperature. Whip is generally caused by a sprung shaft or by an armature imperfectly balanced statically or dynamically; these points must therefore be carefully watched.

Locking screws are a frequent source of trouble. As a dynamo is subjected to intense vibration from various sources it is important that all screws be adequately locked, and attention to this detail is imperative. The method of locking is not so important as the manner in which it has been done.

Loose field stampings occasionally give rise to serious trouble. The method of securing the stampings in position and preventing their rotation must be investigated, and the rigidity of the stampings tested.

Slack internal connecting leads are examined; if these are not securely anchored they sometimes come adrift and foul the revolving parts.

Metal dust in the bearing housings or in the armature tunnel. The stray magnetic field iron filings, etc., tend to resist ordinary methods of removal, and special precautions must be taken to see that the whole machine is free from metal dust and filings.

Armature bearings and wedges must be permanently secure. Shrinkable material which might cause ultimate failure must not be used in such positions.

The following procedure must be adopted before a generator is accepted—

See that the commutator is clean and free from any traces of grease or paint.

That the brush gear is free from carbon and copper dust.

Rotate the armature slowly by hand to confirm that no binding has developed during the cooling down after the load run.

Examine all end inspection covers for fit and weather proofing properties. (Where spares are stored in a box on the generator they are individually

packed in such a manner that they cannot be damaged by rubbing against one another.)

See that the shaft and other bright steel parts are treated for rust prevention by the application of vaseline, grease, or other suitable means.

Check the marking on the label: type identification, serial number, maker's name, year of manufacture, speed in revolutions per minute, output in volts and amps.

Aircraft generators are controlled automatically to give constant voltage irrespective of the load and speed (within certain limits); the average speed is generally about 5,500 r.p.m., but generators operate between approximately 4,000 r.p.m. and 7,500 r.p.m. Generators are, as already mentioned, usually driven by means of windmills coupled to the front end of the generator. The windmill should be properly mounted with its boss on the shaft and locked in position; it should be regarded as a small airscrew (see "Airscrews").

The generator should be mounted on a proper base or in a suitable cradle on the aircraft. It should be away from vapour and flame emitted by the engine, should be kept free of petrol, oil, water, or spray, and clear of anything by which it could be fouled or damaged. It should be kept clean.

The generator is mounted with its axis of rotation parallel to the horizontal datum line of the aircraft and in the unobstructed airscrew slipstream in such a manner that its whole body is exposed to the air flow. The close proximity of struts or other parts of the aircraft structure either forward of or abaft of the windmill must be avoided, as such obstructions may so distort the air flow past the generator that its performance is seriously impaired.

Connections to the generator are, as already mentioned, by means of a plug and socket fitting, the socket being permanently fixed to the generator with internal connections complete. This enables the generator to be quickly removed when not required.

The generator should be so mounted that the supply cables may be readily connected and disconnected; enough clearance must be allowed to permit the easy removal of the end fairing for the examination of the commutator and brush gear without disturbing the main body of the generator.

The generator cradle should be fitted so that the strap may easily be detached when it is required to remove the generator from the aircraft.

In order to avoid compass deviation due to the generator, the generator should be mounted as far as possible from the compass. In aircraft of metal construction the generator mounting, which should itself be of non-magnetic material, should be kept well away from any member of the aircraft which passes near the compass.

Air-driven generators can usually be run up to speed on the aircraft for testing purposes (though not usually to full load) by running the engine on the ground. A satisfactory voltage regulator test, as later described, will also show that the generator is in running order. If a doubt exists as regards its ability to give full output, arrangements should be made for a test by a portable engine with a flexible drive, or the apparatus should be removed for bench test. The following matters should receive attention from time to time—

The bearings should be free. These are usually packed with grease and need no oil.

Commutators should be kept clean and, when necessary, polished with fine grade glass paper.

The grooves between the commutator segments should be free from copper dust and dirt. A fine pointed scraper may be used to clean out the grooves.

Brushes should bed evenly on the commutator and work freely in their holes, the spring transmitting an even pressure of the brush on the commutator.

The bolts securing the brush carrier to the frame should be tight.

Field Shunt

A suitable resistance connected in parallel with the field windings of such a generator as has been described improves the performance of both generator and the control box by—

(a) Reducing sparking at the control box.

(b) Improving commutation.

(c) Increasing generator output.

The shunt consists of a resistance unit totally enclosed in a sheet metal case. The resistance element consists of a flat mica former, wound with 33 S.W.G. bare Eureka wire to a total resistance of 25 ohms. The ends of the resistance wire are brought out to terminal tags on to which are soldered two 8-in. leads of uniflex 4 cable. The terminal tags are riveted in position on the mica former.

The former is mounted between sheets of micanite suitably grooved to accommodate the flexible leads and terminal tags, the grooves being filled with shellac during assembly.

The aluminium case is made in two portions, the front being bent or folded round to enclose the resistance element and the back cover; the whole is then riveted together by means of four brass eyelets, which also form holes for four fixing screws. Washers are riveted in position under the eyelets on the back of the unit to ensure that the shunt stands clear of its mounting when screwed in position. Free circulation of air round the unit is thus permitted.

The shunt should be mounted as close to the control box as possible, and in a vertical position, to permit free circulation of air round the shunt. The flexible leads should be connected to the yellow and slate-coloured terminals of the voltage control box, thus putting the resistance in parallel with the generator field as shown in Fig. 74.

When installing the shunt care should be taken to clear the leads securely and as close to the shunt as possible.

Voltage Control Box

(For control of the air-driven generator described.)

The generator, as already stated, is controlled by means of a voltage

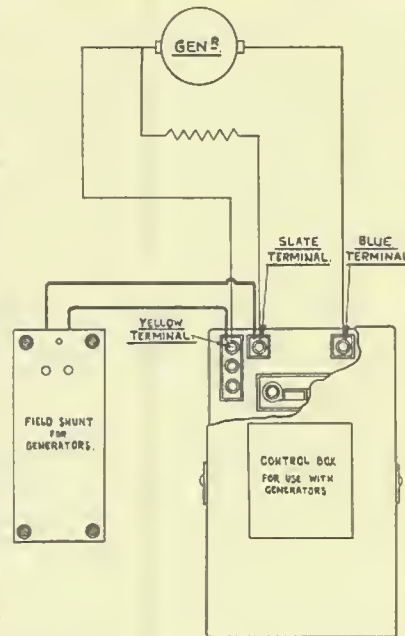

FIG. 74. GENERATOR, VOLTAGE CONTROL BOX AND FIELD SHUNT; METHOD OF CONNECTION

control box. This system of control maintains the voltage at a constant figure. It is used in conjunction with all shunt-wound generators which are not self-regulating. (The apparatus may vary, for example, a late type (vibrating reed type) of control box also incorporates within itself a generator field shunt, instead of this item being separately installed, as is the case in connection with the box here dealt with.)

The apparatus, the arrangement of which is shown in Fig. 74, incorporates a cut-out which automatically disconnects the battery from the charging circuit if the battery begins to charge back into the generator. From Fig. 75 it will be seen that a solenoid coil L_1 is connected across the generator armature terminals. In series with this winding is connected a fixed ballast resistance R_2 . As soon as the generator terminal voltage rises beyond a predetermined value the solenoid operates and breaks the contacts S_1 by the attraction of the armature A_1 . This armature is connected to the lower right-hand terminal via the iron core of the solenoid; this connection is therefore shown by a dotted line in the diagram. The breaking of the contacts S_1 connects the regulating resistance R_1 and the "bucking" winding L_2 in series between the generator field terminal and the negative armature terminal. This weakens the generator field, and the terminal voltage immediately falls. As soon as the voltage falls below normal, the armature A_1 is pulled away from the solenoid by a control spring. The resistance R_1 and the bucking winding L_2 are then cut out from the circuit.

The battery cut-out consists of a solenoid coil L_3 , which is connected between the positive battery connection and the positive generator connection. When the generator is supplying current the coil L_3 energizes the iron core of the main solenoid, and the armature A_2 is thereby magnetized to a definite polarity and attracts the main solenoid, thus closing the bridge contacts S_2 .

The current through the solenoid coil L_3 flows in such a direction as to assist the action of the main solenoid by attracting the armature A_2 about its pivot. It should be noted that the battery is connected across the terminals B_1 , and B_2 as shown. When the battery commences to discharge into the generator the current through L_3 is reversed and the solenoid acts in opposition to the main solenoid. The contacts S_2 now break and the generator armature circuit is disconnected from the control box.

The component parts are mounted on a hollow rectangular aluminium base, which is closed by an aluminium back plate lined with mica to eliminate fire risk. The front aluminium cover is held in position by two brass catches. Inside the cover is a diagram of connections, together with instructions for adjustment.

The instrument should preferably be mounted in a protected position, in order to secure maximum cooling effect, and in such a way that adjusting screws can be readily manipulated (this remark also applies to any separate battery cut-out which may be in any special installation). When handling the control box with the cover removed, care should be taken not to bend or damage any of the springs or moving parts, and to prevent any foreign matter, especially metal such as wood screws, from becoming lodged in the apparatus during installation.

The instrument is supplied by the makers correctly adjusted and ready for use, and except when necessitated by imperfect operation the various adjustments should not be interfered with. (The voltage setting should not be changed provided the voltage is between 13.5 and 15. Under these conditions with a 12-volt 25 amp.-hour accumulator in good condition, all navigation lights can be kept on continuously during all night services.)

The cover should always be kept on to protect the instrument from accidental damage.

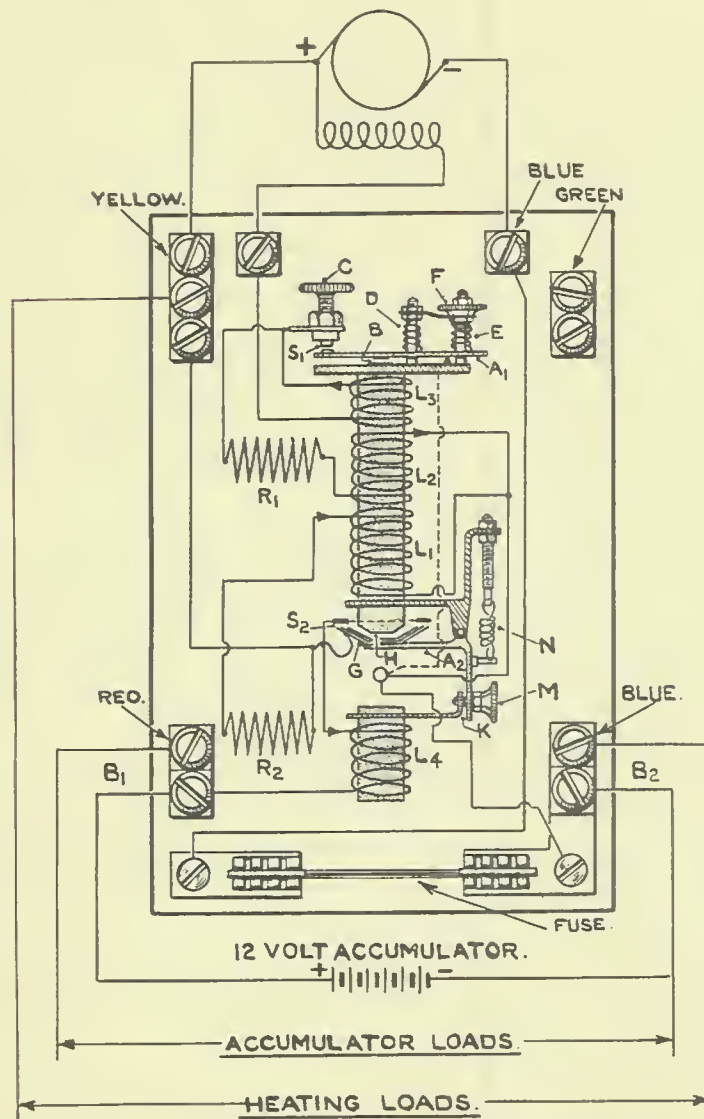

FIG. 75. VOLTAGE CONTROL BOX— DIAGRAM OF CONNECTIONS

The regulator is set to give 13.5 volts when cold; during flight this may rise to 15 volts, owing to temperature effects, but the average value should be about 14 volts.

The battery cut-out is set to close at about 12.5 volts and cuts out with a discharge current of about 4 amps. The magnetic circuit of the battery cut-out is arranged to react on the main solenoid circuit in such a manner that a charging current into the battery has the effect of slightly reducing the generator voltage, the reduction in voltage being dependent on the charging current. The voltage change is, however, small, being about .5 volts, with a charging current of 15 amp.

The foregoing effect is an advantage because it tends to limit excessive charging current into the battery, which is almost discharged. As the battery voltage rises the charging current is reduced, and the generator voltage rises accordingly until the battery is fully charged and is floating with full voltage from the generator.

The vibrating contacts of the regulator should be clean and the carrying arm free in its bearings.

The brush blades of the cut-out should be clean and making good contact when the cut-out is in charging position.

Tests are made with a portable voltage tester. This instrument contains a voltmeter with flexible leads and plugs for connecting it to the regulator; the instrument, which incorporates a telephone jack, provides a simple means for testing whether the controller is maintaining the correct generator voltage, and the telephones give an aural indication that the regulator is in operation. Instructions for use of the testing instrument are to be found inside the cover.

With full load on the generator some sparking will be observed at the regulator contacts. This is quite normal and has no adverse effect.

If any voltage adjustment is required during flight, the tension of the front control spring on the upper armature should be adjusted by the milled screw *F*. No other adjustment should be attempted when in the air; other adjustments should be made during overhaul on the ground.

At the end of every 100 flying hours the control box should be carefully overhauled. The regulator and battery cut-out contacts should be carefully cleaned and readjusted, the method being as follows—

- (a) Disconnect the battery leads.
- (b) Remove the armature *A*₁ and the screw *C*.
- (c) Clean and burnish the contacts *S*₁ and replace armature and set screw. See that the contact faces are parallel after cleaning.
- (d) Set the air gap *B*, the armature and solenoid core to the thickness of a .015 in. feeler by the adjusting screw *C* and tighten up the lock nut. When setting the air gaps see that the contacts are closed and the armature properly seated on the fulcrum.
- (e) Tighten up the tension spring by giving two complete turns of the securing nut and tightening up the lock nut.
- (f) With the generator running at 4,000–5,000 r.p.m. and the voltmeter connected across the yellow and blue terminals, set the voltage to 13.5 by adjusting the tension of the spring *E* by means of the screw *F*, and after adjustment secure with the lock nut.

To adjust the battery cut-out—

- (a) Disconnect from the accumulator and remove the armature *A*₂.
- (b) Clean and burnish the contacts *S*₂ and replace the armature.
- (c) Adjust the bridge contacts *G* to obtain even contact; when contact is just made the air gaps should be the thickness of a .015 in. feeler.
- (d) Set the stop screw *M* to give maximum opening of the air gap *H* to thickness of feeler.
- (e) With the generator running, adjust the tension of the spring *N* until the contacts close at approximately 12.5 volts.

(f) Connect the accumulator and finally adjust the spring *N* until the contacts open with a battery discharge current of 4-5 amp.
After adjustments tighten up all lock nuts.

Note. On some control boxes a single pole fuse is placed in common negative main circuit; in others there is no fuse, all fusing being done externally.

Engine-driven Generator

The generator here described is the alternative of the air-driven type and has an output of 500 watts at 14 volts at about 5,000 r.p.m. at normal cruising engine speed. It is directly driven from the engine and in connection with the accumulator is self-regulating.

A suitable accumulator cut-out and a manually operated position switch, together with a resistance enables the charging current to be

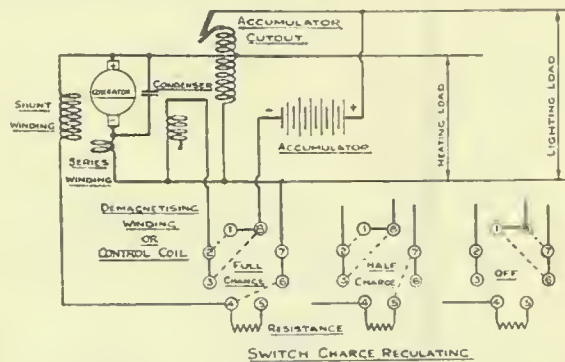

FIG. 76. ENGINE-DRIVEN GENERATOR—DIAGRAM OF CONNECTIONS

reduced when the accumulator becomes fully charged, or the generator to be switched off completely.

The control of the generator is effected by special field windings in connection with the accumulator. The shunt-field winding is connected across the lines, and the armature current is passed through a series winding to give load compensation as in an ordinary compound wound generator. The control winding is of low resistance and wound in the reverse direction, and carries the accumulator current only.

When the system is in operation the voltage of the generator rises until the cut-out contacts close and charging current flows to the accumulator. This charging current, flowing through the control winding, exerts a demagnetizing force on the field system and prevents any further material rise of voltage. Thus, as the speed of the generator increases the charging current automatically rises just sufficiently to give the necessary reduction in field strength and maintain the line voltage approximately equal to that of the accumulator. As all external load currents are supplied directly from the generator, and do not pass through the control winding, the charging current and voltage control are independent of the load conditions. When the generator falls below the minimum speed at which it can supply the load connected, the cut-out contacts open and lighting loads are maintained from the accumulator through the control winding, which is of low resistance.

The line voltage under normal conditions is always slightly in excess

of the accumulator voltage and as the latter rises as the accumulator approaches the fully charged state, a switch is provided to reduce the charging rate, thereby restoring normal voltage and avoiding excessive overcharging. The switch has three positions: "off," "half charge," and

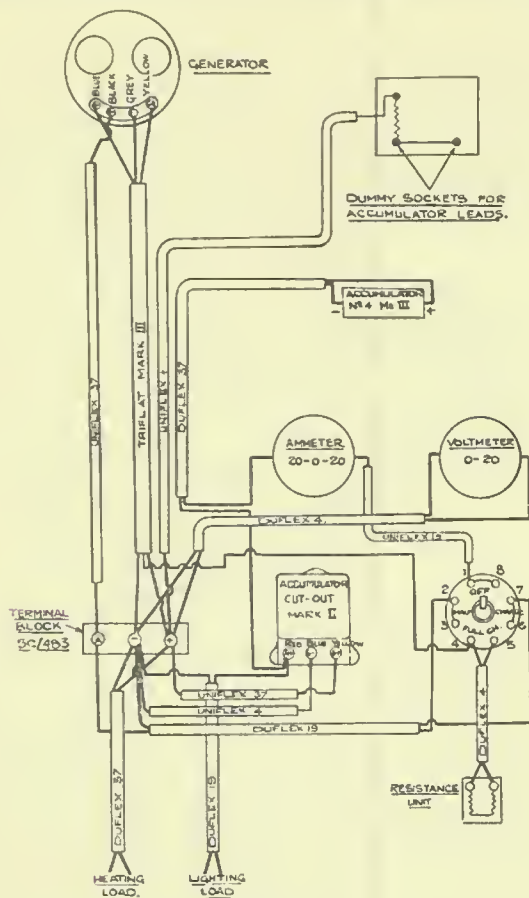

WIRING DIAGRAM.

ENGINE DRIVEN SELF-REGULATING 500WATT.

GENERATOR

FIG. 77. ENGINE-DRIVEN GENERATOR—WIRING DIAGRAM

"full charge." The effect of moving the switch to the "half-charge" position is to insert the resistance unit into the shunt-field circuit of the generator. When the switch is in the "off" position, the accumulator is connected directly to the lighting mains, and the generator shunt and control field circuits are broken, thus preventing excitation of the generator.

Dummy accumulator sockets are wired to the system in such a way

as to prevent excitation of the generator if the aircraft is flown without an accumulator. This is effected by connecting the negative accumulator lead to the generator positive lead, thereby converting the generator control winding into a powerful shunt winding of demagnetizing polarity when the control switch is in the charge positions. Connection to the positive accumulator lead is immaterial, but the dummy terminals are connected together so that in stowing the leads polarity need not be observed.

A small resistance (about 1 ohm) is incorporated in the dummy terminal block. The object of this is to limit the short-circuit current which would flow in this circuit due to the residual generator voltage when the control switch is in the "off" position.

With the control switch in the "off" position the generator is out of action, and the lighting loads and essential services are supplied from the accumulator. At the beginning of a flight, the switch should be placed in the "full charge" position, when the generator will supply all loads connected and in addition charge the accumulator at about 3 amps.

After a time, depending upon the initial state of the accumulator, the fully charged state will be approached. This will be shown on the voltmeter by a rise in voltage which, if allowed to continue, may possibly reach 17 volts. The switch should be moved to the "half-charge" position when the voltage exceeds $14\frac{1}{2}$ volts. This reduces the voltage to about 14 volts and the charging rate to a small value (0 to 1 amp.). Where a fully charged accumulator is placed in the aircraft this effect will usually occur in the first few minutes. Throughout the remainder of the flight no further attention should be necessary.

It is imperative that the engine should not be run unless the accumulator leads are properly connected to an accumulator or stowed in the dummy sockets provided. A faulty connection in this circuit will lead to excessive voltage and damage to the generator and any services connected if the control switch is inadvertently placed in the "charge" position.

21. ACCUMULATORS

Lead-acid Accumulators

(No account is here taken of ordinary bench recharging, as it is considered beyond the normal function of the ground engineer. Charging from the generator has already been dealt with.)

Accumulator cells (see Fig. 78) usually consist of several positive and negative plates (generally made of lead and paste filled), arranged alternately throughout the cell.

Each positive plate has a negative plate on each side of it. The plates are prevented from touching by separators, usually celluloid, ebonite, or wood partitions arranged so as to permit free circulation of the electrolyte between the plates. If this is impeded by any means, the electrolyte will not be of uniform density throughout the cell, which will result in buckling of the plates and the shedding of active material.

The separators always have vertical grooves further to allow of the equalization of the electrolyte density. A certain amount of space is left between the bottom of the plates and the separators to allow any active material which may be shed in the form of sediment to fall to the bottom of the container clear of the plates, which it would otherwise short circuit. The electrolyte in all ordinary cells consists of sulphuric acid of a specific gravity of 1.84 diluted with distilled water to a specific gravity of 1.27. The specific gravity of the electrolyte may be tested by a hydrometer, several special kinds of which are obtainable for this purpose.

For aircraft purposes the weight and size of accumulators are kept at a minimum with some sacrifice in life.

The normal useful life of such accumulators in temperate climates may be reckoned as about 70 complete cycles of charge and discharge at the 10-hour rate, or 700 working hours at 10 hours a day. If the working hours are 5 per day then the useful life would be approximately 2,000 hours; it may be thus said that the useful life may be taken as from three to five months.

Under tropical conditions the life may be very considerably shortened, even to one or two months.

By useful life is meant the number of cycles of charge and discharge which reduces the original cell capacity to 40 per cent. In tropical climates frequent inspection is necessary and evaporation

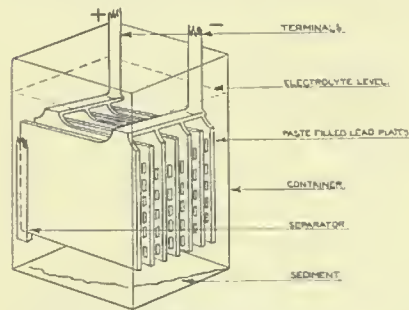

CONSTRUCTION OF MULTIPLE PLATE CELLS

FIG. 78. ACCUMULATOR—CONSTRUCTION OF MULTIPLE PLATE CELLS

of the electrolyte, if rapid, should be compensated for by "topping up" daily with distilled water.

The voltage of an accumulator in a fully charged condition is practically a fixed quantity. On open circuit the potential difference between the positive and negative plates is usually about 2.2 volts. The terminal voltage falls as the cell discharges, the rate at which the voltage falls being dependent on the rate of discharge. In Fig. 79 a curve is given showing the fall of the voltage on discharge at the 10-hour rate.

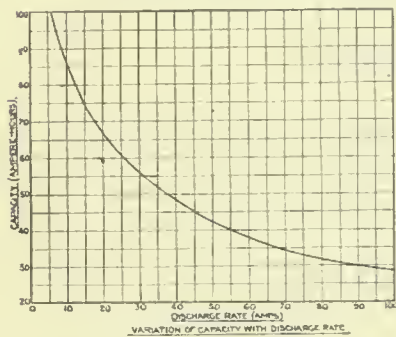

FIG. 79. VARIATION OF CAPACITY WITH DISCHARGE RATE

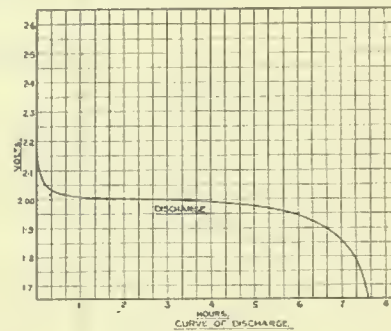

FIG. 80. CURVE OF DISCHARGE

The capacity of an accumulator is its output expressed in ampere-hours. The capacity thus represents the product of the current (in amperes) and the time (hours) for which that current can be taken from the cell when fully charged until the terminal voltage falls to 1.8 on load. The normal rated capacity of a cell is usually based on the 10-hour rate of discharge, i.e. the current which will discharge the cell to 1.8 volts in 10 hours; when this discharge rate is exceeded the capacity is reduced. It should be realized that a 40-amp.-hour accumulator will not give 20 amp. for 2 hours

nor 10 amp. for 4 hours; it is rated to give 4 amp. for 10 hours, and if the discharge current exceeds 4 amp., the ampere-hour capacity will be reduced. For example, in Fig. 80 if a 2-volt 90 amp. accumulator is considered—

At the 10 hour rate its capacity is	90	amp.-hours
„ 5 hour „ „	75	„
„ 1 hour „ „	45	„

This means that the accumulator will give 9 amp. for 10 hours, 15 amp. for 5 hours, or 45 amp. for 1 hour. In each instance the current rating of the accumulator for the period specified is that which would bring the terminal voltage of the cell down to 1.8 on closed circuit starting from the fully charged condition. The capacity of any cell is not, therefore, a constant quantity, but depends on the amount of active material in the plates.

Faults

The following faults may be attributed to improper treatment of free acid accumulators—

Sulphation, hydration, buckling of plates, disintegration of plates, internal short circuit, damaged containers.

Sulphation is the most common fault, generally caused by neglect by (a) discharging below 1.8 volts per cell, (b) allowing to stand partly or wholly discharged, (c) continuous undercharging, (d) using too strong an electrolyte.

The treatment for sulphation consists of (1) emptying and washing out with weak electrolyte; (2) refilling with weak electrolyte (specific gravity about 1.15); (3) sending for charge at one-quarter the normal rate with instructions to allow to gas steadily, thereby dislodging insoluble sulphate which falls as sediment. (It may be necessary to continue this charge for 100 or more hours.) (4) emptying out, washing out sediment with weak electrolyte and filling up with normal fresh electrolyte; (5) charging the cell at the normal charging rate for a short period.

Should the above treatment not be successful in removing the insoluble sulphate, the cell may be carefully dismantled and the plates taken out, scrubbed, and scraped carefully to remove hard sulphate. Great care is essential in order not to disturb the paste or active material of the plates in any way. Re-assemble the cell and place on slow charge until restored to normal condition. However careful the treatment, it should be noted, of course, that the life and capacity of the cell will have been impaired by sulphation.

Hydration is caused by allowing water to remain in contact with the active material of the plates for a long time. New accumulators should not be rinsed out with distilled water before the first charge. Hydration interferes with the chemical changes which take place during charge and discharge and impairs capacity. Treatment consists of prolonged charging on the lines of (3).

Buckling of Plates is generally due to excessive rates of charge and discharge causing uneven chemical action in the active material of the plates, which are thereby buckled by the stress. To remedy, the plates should be taken out and pressed gently between pieces of board, due care being given to the brittleness of the plates and the likelihood of loosening active material and causing shedding.

Disintegration of Plates may be caused by general neglect, prolonged overcharging and continuous charging at current strengths much less

than those indicated on the label; the result is peroxidation. There is no remedy. The consequent sediment should be removed to prevent it short-circuiting the plates, the cell being carefully shaken and emptied, filled with fresh electrolyte and sent for charge at one-half the normal rate.

Internal Short Circuits will be indicated to the persons responsible for charging. They may be caused by neglect or by lead "growths" (which will expand when warm) due possibly to prolonged undercharging below the normal rate. The plates should be taken out and cleaned of any excrescences.

Damaged Containers may result from stopped-up vent holes. When sending for charging, those responsible should be informed of any sealed vents. Celluloid cased accumulators should be kept out of the discolouring and strength reducing heat of the sun. High temperature from any source may cause discoloration and warping and cracking of containers, sulphation, hydration and buckling of plates, inability to hold charge, and expansion of positive plates during charge to such an extent as will result in entire failure.

Inspection

Terminals should be tight and a light coat of vaseline should be applied to prevent detrimental effects due to acid. Vent plugs should be tight. The electrolyte should be kept to the proper level in accordance with instructions or level-mark. Cables to the accumulator must be correctly attached as regards polarity—red cable to positive and blue to negative. The cable terminals should be fitted in a dummy plug when not in use. Accumulators should not be left in an uncharged or partially charged condition, as either will lead to sulphation. When not required for use they should be given a freshening charge at least once a month.

Test

The condition of an accumulator can be ascertained by a discharge test at the 10-hour rate (discharging at a current equal to one-tenth the nominal capacity) and the voltage recorded against time. A fully charged accumulator will give about 2.1 volts at the start of this test and not less than 1.8 volts per cell after 10 hours. If the voltage falls to 1.8 in less than 6 hours it will indicate that the accumulator is not in a very serviceable condition. Accumulators must be wholly of the non-flame or non-flame-top type, and preferably non-spillable (in acrobatic aircraft they are compulsorily so). They must be kept as far as possible from fuel tanks and engine.

The accumulator should always be protected from the weather, housed clear of all the usual places of passenger occupation and of all hand and walk ways, etc., but of course should be easily accessible at all times for inspection, test of electrolyte, voltage, etc., recharging and general maintenance. Care should be taken that it is securely fastened and locked in place, taking into account vibration. All live parts of the accumulator must be enclosed or protected. The box or compartment into which the accumulator goes must be adequately vented, must insulate the accumulator's celluloid sides (if applicable) from the air, and it must be entirely leak-proof. Spilled acid is highly destructive to most materials; it may find its way to a stressed member of the aircraft and by its rapid attack cause structural failure. Any signs, therefore, of free acid must be at once investigated.

Alkaline Accumulators

The nickel-iron accumulator is now very often used in place of the lead-acid type and owing to its long life and durability is especially suited for use in aircraft where the working conditions are extremely vigorous.

The positive and negative terminal plates are perforated nickel-plated steel containers which are filled with the active material. The plates are welded or bolted together for similar polarities and separated by strips of hard rubber. Each cell container is a thin welded nickel-plated steel box entirely closed except for a special non-spillable gas release-valve which effectively prevents spilling of the electrolyte while allowing the gases generated during charging to escape. An important characteristic of this cell is that it may be charged or discharged at a very high rate and left in a discharged condition without injuring it in any way.

Accumulators must be capable of supplying navigation lamps, identification and landing lights, etc., and all services where continuity and existence of current is essential for at least 30 min. after the generator has stopped.

22. LOW TENSION INSULATED CABLES

There are many different classes, all L.T., of cables used in the electrical general service equipment of aircraft. Each class has a different number of cores from that of any other class. The cores consist of stranded tinned copper insulated by pure vulcanized rubber sheaths and wrapped in coloured cotton. In some cases the rubber sheathing itself is coloured. The number of cores comprising the cable of each class is indicated by the prefix of the class name (see Fig. 81).

Thus the class of cable containing a single core has a prefix "uni" that containing two cores "du," that containing three cores "tri," and so on. In nearly every class there are four types of cable; each type differs from the others in its class by the nature of the sheath in which the cores are enclosed. The nature of the covering sheath is indicated by the suffix of the class name; thus: the suffix "flex" (flexible cables for general use in protected positions) indicates that the core or cores are covered by a sheath of braided cotton; the suffix "proof" (waterproof cables) indicates that the cores are covered with a braided waterproof material; the suffix "sheath" indicates that the cores are enclosed by a tough rubber sheath for use in unprotected positions where they are liable to be rubbed against or otherwise roughly treated. The numeral following the name of the cable denotes the permissible current carrying capacity of that particular cable. Thus "uniflex 4" will carry 4 amp. "duflex 19" will carry 19 amp., and so on.

At standard current rating and for small cables up to and including 19 amp., all the sizes allow a drop of .1 volt per yard run, 37 amp. cables allow a drop of .1 volt per yard and a half run, 64 amp. cables allow a drop of .1 volt per two and a half yards run. In the fifty power cables carrying 175 amp. the voltage drop is .1 volt per yard run.

The fourth type of cable is of the sheath type closely braided with metal wire and is for use in aircraft in which directional wireless is installed.

In addition to these cables is a cable known as "Tripod" which is similar to "tri-sheath," except that it has cores of different colours. Tripod is a metal wire braided cable.

Special cables, "Triflat," are used for connecting up generators. The cables consist of three insulated cores contained in a shallow sheath of tough rubber. Triflat is also supplied braided with metal wire.

The cable known as fifty power is for connecting up electric starter motors. The core is a large diameter-stranded cable insulated by pure

vulcanized cambrie tape and by one plain and two oil-resisting layers of varnished cambrie tape. It is closely braided with paint impregnated cotton.



UNIFLEX

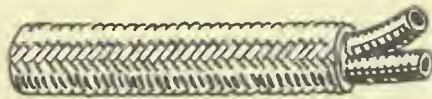

DUFLEX



TRIFLEX



QUADRAFLEX

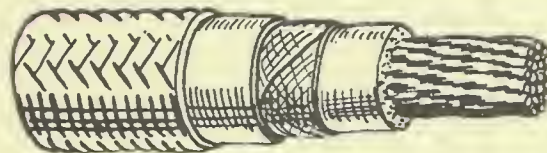

50 POWER CABLE

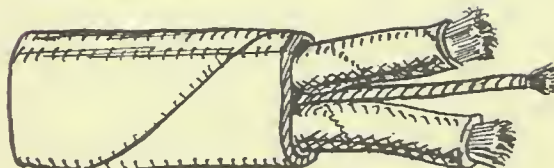

TRIFLAT



FIG. 81. TYPES OF CABLE

For instrument lighting a cable known as "instruflex" is used. This consists of two plain stranded copper cores insulated and wrapped respectively with red and black cotton. The cores are not enclosed in a sheath but are twisted together.

Below is given a list of stranded low tension cables—

<i>Type</i>	<i>Number.</i>
Uniflex	4, 7, 19, 37, 64.
Uniproof	4, 7, 19, 37, 64.
Unisheath	4, 7, 19, 37, 64.
Unisheath braided	4, 7, 19, 37, 64.
Duflex	4, 7, 19, 37, 64.
Duproof	4, 7, 19, 37, 64.
Dusheath	4, 7, 19, 37, 64.
Dusheath braided	4, 7, 19, 37, 64.
Triflex	4, 7, 19.
Triproof	4, 7, 19.
Trisheath	4, 7, 19.
Trisheath braided	4, 7, 19.
Tripod	
Tripod braided	
Triflat	
Triflat braided	
Quadriflex	4, 7, 19.
Quadraproof	4, 7, 19.
Quadrasheath	4, 7, 19.
Quadrasheath braided	4, 7, 19.
Twensevenflex	2.
Fifty power	
Instriflex	
Quintoflex	4, 7.
Quintoproof	4, 7.
Quintosheath	4, 7.
Quintosheath braided	4, 7.
Sextoflex	4.
Septoflex	4.
Nonoflex	4.

Where screened metal-braided cables are required in an exposed position, and where there is a danger of damage or corrosion to the braid, the following are used—

Dumet	4 T.R.S.
Tumet	4 T.R.S.
Quadrumet	4 T.R.S.
Quintomet	4 T.R.S.

The letters T.R.S. indicate a tough rubber sheathing over all.

Lately, cellulose varnished cables have come into use; these follow upon the lines of the above, being named unicel, ducl, tricel, and numbered 4, 7, 19, etc., as the case may be.

It should be borne in mind that all cables here dealt with are designed with special regard to lightness in weight and they are not suitable for hauling through small holes or other confined spaces. Every precaution should be taken that they are not subjected to undue stress.

Electrical systems which the cables are called upon to serve may be grouped under these headings: ignition, wireless, intercommunication, and general.

For the purpose of recognition the cables serving the various systems have coloured coverings or are coloured distinctly during their installation and are secured by appropriately coloured cleats. The colour scheme is as follows—

Ignition	blue
Wireless	red
Intercommunication	green
General	yellow

The colours are also borne by the ends and the respective cleats and elsewhere to allow the run of the cable to be traced. Where cleats are inadmissible the cables are painted with bands of their distinguishing colours.

The cores of the various types of cable are wrapped in coloured cotton lapping as already mentioned. The colouring denotes the polarity or function of the core.

The general colour scheme is as follows. Single colours are used as far as possible, and extensions of these colours are employed for multiple cables. Those in most common use are—

- Single core, natural colour.
- Two cores, red and blue.
- Three cores, red, blue, and green.
- Four cores, red, blue, green, and yellow.

The key colours for main circuits are—

- Red accumulator positive circuits.
- Blue negative, all circuits.
- Green neutral.
- Yellow generator positive circuits.
- White used as special cases demand.
- Grey generator field conductor in triflat cables.

Cable Installation

Care must be taken to prevent cables coming into contact with moving parts such as control wires, or levers, or sharp edges of fittings or ducts or other equipment.

Where practicable it is advisable that the lengths of cable should exceed the minimum necessary to meet installation requirements by approximately 2 in., so that if end breakage occurs the connection can be re-made without using new cable. The excess lengths at the ends of the cable should be properly secured.

No splicings, twistings, solderings, or any other joints are permitted in a length of cable.

There must be no risk of oil, petrol, or dope coming into contact with the cables, which must be installed in such a way as to not be liable to accidental damage by persons getting into or out of, or moving about, or in the course of flying in, or maintaining, the aircraft.

Wherever necessary, cables must be protected from the effects of weather, sea water, dampness, or other atmospheric or similar deleterious conditions.

The progressive effects of continuous vibration must be carefully guarded against. The cables should only be taken through bulkheads, fairings, fabric, and the like by means of adequately bushed holes.

The installation should provide for adequate support to the cables throughout their length, unnecessary hangings, loops, or slacknesses, or undue stressing being strictly avoided.

The fixings for cables, ducts, cleats, and the like, or any other item of the electrical equipment must not involve the drilling of holes or the making of passage ways which are liable to weaken any part of the aircraft structure.

Cable ends must be properly finished off as described hereafter and whilst being securely fixed in their terminals or other appropriate fittings, must not be under any mechanical stress; due allowance should be made for expansion and contraction, and for torsion of the structure.

The various items of equipment should as far as possible be grouped

together on one side of the aircraft, to simplify wiring and connecting up and to avoid wiring being taken across the fuselage or hull.

Cable runs for general lighting and heating circuits must not be run in common ducts with wireless, ignition, or other circuits and must in fact be separated as far as available space permits.

Serious interference with W/T and direction-finding apparatus may result from the close proximity of other electrical systems. The cables must be readily accessible throughout their length in order to facilitate inspection or replacement.

Cables may be carried in systoflex or in open metal ducts or tubular fairings or conduits. Open ducts designed to carry a number of cables should be provided with front covers or narrow clips which can be sprung on the edges of the ducts. Such ducts are sometimes lined with sponge rubber, which lightly pressing on the cables when the trough is closed, prevents movement.

It is advisable to stencil, or mark with a coloured band in accordance with the key as already given, all closed troughs and ducts.

Tubular fairings and circuits must have clean, smooth bores. Ducts and fairings should be bell-mouthed bushed to prevent abrasion cutting through the cable insulation, with consequent short circuiting. Metallic cable conveyances as mentioned above should of course be "brought in" the bonding system of the aircraft where applicable.

To facilitate erection and dismantling the aircraft, suitable provision should be made for severing and re-uniting the electrical circuits at the junction of detachable components. A terminal block is suitable for this purpose, provided it is easy of access.

On aircraft with folding wings the terminal block should be placed near the hinge joint, and the cable arranged in such a way as to obviate any detachment, fraying, or detrimental effect.

Adequate precautions are to be taken to prevent the twisting of cables whilst being drawn through tubes or fittings; such twisting leads to the formation of kinks and possible fracture.

If it is ever necessary to leave cable ends loose they should not be left bare. Each end should be protected by wrapping with insulating tape. Bare ends should never be twisted together. Along spars, struts, longerons or decking, where a clear run may be obtained without the cable fouling metal fittings, the cable or cables may be attached with aluminium cleats. These may be formed by lengths of aluminium strip bent to shape as shown in Fig. S2a and secured at each end with a small woodserew. The cables where they pass beneath the cleat should be armoured against abrasion by being covered with a case of rubber or systoflex (insulation-impregnated braided cotton) strip or tube. Where more than one cable is secured by a single cleat the set is wrapped together in a protecting strip or passed through a common length of systoflex tubing. Where the cables pass transversely across a spar, strut, or longeron, the protective covering is carried $\frac{1}{4}$ in. beyond each edge.

Through decking and solid ribs where the cable is taken through a structural component of the aircraft it is protected by a bush of petrol-resisting rubber piping of sufficient length to project for $\frac{1}{4}$ in. on each side. The bush is a comfortable fit for the cable before assembly and a snug fit in its hole.

Should any difficulty be found in drawing the cable through its bush, French chalk is the only lubricant permissible.

It is impossible, as a rule, to carry a cable along the face of the main spars inside planes owing to its fouling bracings and other metal fittings;

it is therefore often suspended to the rear of a spar in straps of the type in Fig. 82*b*. The free ends of the strap are secured to the various ribs by small screws or fastenings.

Through fabric the cable is passed through a leather washer sewn to a patch: this patch is doped to the fabric so that the washer is located between the fabric and the patch.

Covered components should show the presence of internal electrical fittings or attachments by bearing upon inspection doors or patches an inscription such as "Electrical connections here," etc.

Between fin and tail plane the cable is run in the manner shown in Fig. 82*a* and is taken up the rear vertical spar, often terminating in a plug socket unit clipped to the side of the spar on the outside of the fabric; from the plug a length of cable is run inside the fabric of the rudder to emerge again close to the tail navigation lamp mounting. A short loop is left between the plug and where the cable enters the rudder of sufficient length to permit free movement of the rudder. The loop and the portion of the cable close to the navigation tail lamp fitting which is outside the rudder is enclosed in a length of rubber or systoflex tubing, the ends of which are served with prepared twine to prevent the entry of water.

Where cables are taken along tubular structural members of metal aircraft they are secured by being bound with six turns of 22 S.W.G. tinned-copper wire; the individual turns of the binding are soldered together in two places across a diameter of the tube so that the heat of the soldering does not damage the insulation of the cables; the cables are protected against abrasion as already described in the case of installation. "along spars, struts," etc.

Where cables cross members of all-metal aircraft they are secured by cleats of the type shown in Fig. 82*a*. These cleats are wired in place and the cables protected against abrasion in the usual way. Cleats must not be secured to hollow or built-up wooden spars or other components likely to be split or damaged by their being secured with wooden screws. If possible the cleats should be fitted only at places stiffened by packing blocks, and the cables should be supported at intermediate points by doped fabric or other suitable slings.

Live wires in the vicinity of fuel tanks and pipes must be suitably encased.

All cable ends at terminals should be distinctly marked: this is often done by coloured sleeving and sleeves bearing the name of polarity and service.

When making-off ends of cables, no frayed ends should be left out, all strands being in good contact. The following is a method of preparation—

Cut the outer covering back $1\frac{3}{4}$ in., fit the identification sleeve over the outer covering, serve with sailmakers twine or thread, cut the inner covering back according to the size of terminal screw, make and form the bare copper end into an eyelet, then bind the shank end with insulating covering tape or thread of the correct colour. Care should be taken that no strands are severed during insulation stripping.

Except in special cases soldering together of the individual strands of a flexible cable is not permissible, as strands may be easily broken and the general flexibility of the cable at the soldered joint is lost.

Soldered cable ends may be required where—

1. Slotted terminals are employed with an inside screw pressing on the cable ends; in such cases a soldered shank should be formed on the end of the cable.

2. Small eyelets with lugs are used.

3. Lugs with thimbles are used, as on some plugs and sockets.

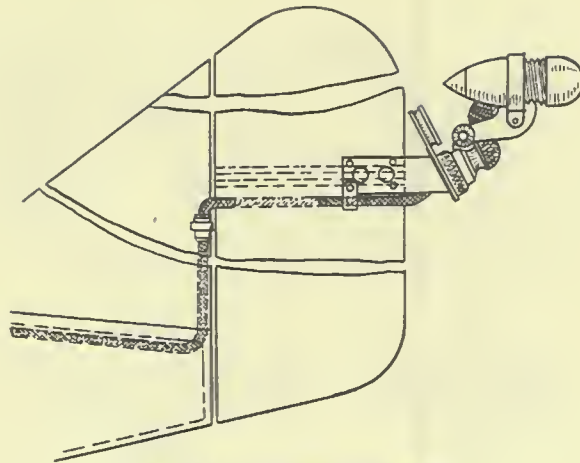

METHOD OF RUDDER WIRING.

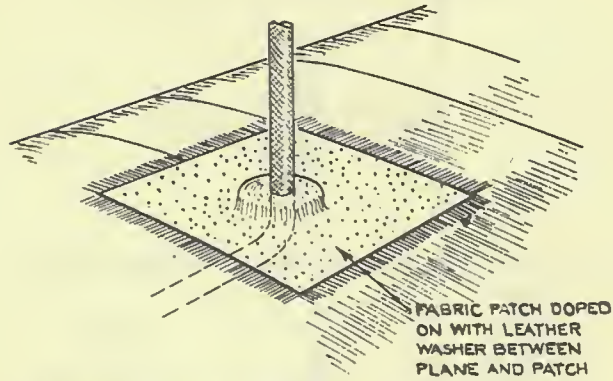

FABRIC PATCH DOPED ON WITH LEATHER WASHER BETWEEN PLANE AND PATCH

METHOD OF BRINGING CABLES THROUGH FABRIC.



METHOD OF WIRING IN ALL METAL AIRCRAFT.

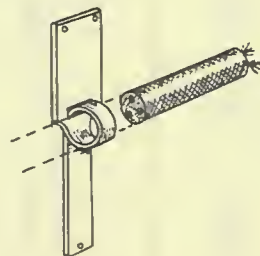

METHOD OF CARRYING CABLES THROUGH PLANES.

FIG. 82a

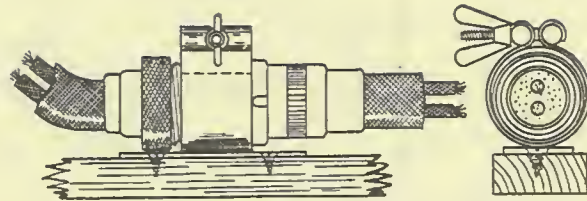

METHOD OF CLIPPING CIRCULAR PLUG AND SOCKET CONNECTORS IN FUSELAGE, WINGS, ETC:



METHOD OF CLEATING ON BATTENS .

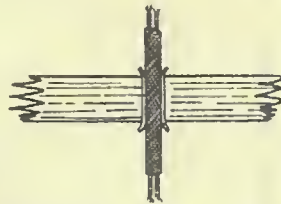

METHOD OF BRINGING CABLES THROUGH WOOD.



METHOD OF FIXING CABLE ENDS AT TERMINALS.

FIG. 82b

When soldering cable ends to plugs and sockets such as for the generator, care should be taken to apply as small an amount of heat as is necessary for a good joint. Heat destroys the properties of ebonite and bakelite commonly used for plugs and sockets. The fit of the plugs and sockets should be checked after soldering; it will often be found that slackness in the bases, requiring taking-up with a proper tool, has followed this operation.

For soldering, a non-corrosive type of flux, such as resin, should be used; at the conclusion of the operation connections and adjacent ebonite parts which tend to become adhesive and attract metal dust (with a resultant low megger test reading) should be washed in warm water and dried.

Soldered cable ends are not permitted with—

1. Cylindrical holes and grub screws.
2. Terminals consisting of a circular hole with diametral slot, a central screw with large head and a washer.

A soldering thimble consisting of a thin copper tube passed over the end of the cable and spot soldered is used on all items of electrical equipment where the grub screw method of attachment of the cable is employed.

Examination consists, of course, in the general verification of the foregoing. Cables should be examined periodically to ensure that the insulation has not been damaged by contact with moving parts or persons and has not deteriorated from petrol, oil, sea water, dampness, wear and tear, or other cause. The cleating should be inspected to see that no damage has occurred as the result of vibration. The insulation tests which are later described will also give an indication of the general condition of the cables. See that—

(a) These general service circuits are, as already instructed, kept as remote as possible from other circuits especially W/T and D/F, in order to reduce risk of interference with external communications; and that in no circumstances have common runs or ducts been adopted.

(b) Where aluminium or duralumin tubes or ducts are used for the accommodation of cables they are suitably protected against corrosion.

(c) All wiring is suitably marked as necessary to facilitate identification.

(d) All cables are free from joints of any description except where terminal blocks or other approved means, adequately protected, are employed.

(e) Where cables having an absorbent covering are used and any part of the cable is or could come in contact with the aircraft structure (conduits or ducts are not regarded as parts of the structure) such parts of the cable are separated from the aircraft structure by a non-hygroscopic medium. (Systoflex or material of a like nature is suitable for this purpose.)

(f) All cable ends are properly prepared.

(g) The rubber and other outer coverings of wires and cables are not allowed to come into contact with dope, petrol, oil, or similar preparations having a deleterious effect thereon.

(h) A non-corrosive flux has been used for any soldering.

(i) The conductors or cables are free from stress where they are attached to terminals or other fittings, and that the body of the cable is securely clamped at a point as near as possible to the terminal or fitting by means of a suitable clip.

(j) Where an insulating separator is required between two metallic bodies, no process which tends to reduce the efficiency of the insulator as such is used. The use of any metallic oxide paint or metallic dope is prohibited. (Soaking of the insulator in paraffin wax or varnish is permitted.)

23. GENERAL ELECTRICAL PARTS, COMPONENTS, AND ACCESSORIES

Switches

There are three kinds of switches in common use, knife, rotary, and tumbler; they are used for making and breaking electrical circuits. They should be arranged easy of access but beyond the possibility of accidental operation. The influence of gravity upon knife switches should be to make them remain off when "open," and not fall into contact.

The action of most switches is accelerated by the incorporation of spring "snap" devices which prevent prolonged arcing but nullify any hesitancy of operation.

The switches should be of ample proportions to deal with the current in the particular circuit, and all movable current-carrying parts should make good electrical contact. There should be no sloppiness in jaws or hinges; faulty contact will cause burning of the parts and result in flickering or failure of the service controlled.

Fuses

Fuses must be installed in all electrical circuits other than engine starters and magneto ignition. They must be of the enclosed type and projected against accidental damage and the terminals against accidental contact; they must be suitable for the kind and size of circuit into which they are inserted to protect. Fuse boxes, groups, or items, should be located where the fuses can be attended to and replaced easily. Fuses should be examined for signs of overheating, which may be due to overloading of the circuit or to poor electrical contact with the fuse clips. A blown fuse should be replaced by one of the same current capacity after having investigated the cause of the blowing. Heavier or lighter duty fuses than the correct ones would be dangerous in a circuit: the latter will readily blow and the former probably cause rupture of the circuit.

Terminal blocks and distribution boxes usually have a base of insulating material upon which are mounted the terminals to which the cables are attached for the linking up of the various circuits. The terminals should be properly separated and at the correct distance apart. The screwed devices should bear well upon the cable ends and be secured so they will not slack off. The terminals should be kept covered to prevent damage and accidental earthing or short-circuiting of the phases by conductive material coming into contact with them.

Plugs and Sockets

Should make good electrical contact, cable ends being securely attached to their terminals. Points of exit and entry of the cables should be examined as regards wear and tear. Neither fuses nor plugs and sockets should be put into or taken out of circuit with the current on. The circuit should be broken by switch and only "made" again when the fuse or plug has been inserted.

Voltmeters and Ammeters

These are not normally repairable outside the maker's factory. The cable connections to the instruments should be examined to ensure that they are correctly, firmly, and securely connected. Any zero error should be corrected by means of adjusting screws where fitted.

Navigation Lights

Are usually so constructed that they can be easily removed from the aircraft when not required. A plug is usually embodied in the base of the lamp, which is inserted into a socket permanently fixed to the aircraft, the socket being connected in the electrical system. The pins should fit the sockets in such a manner as to ensure good electrical contact, and the lamp fitting must be quite secure when fixed in position, the fixing gland nut being lubricated occasionally to prevent tightness. A weather-proof cap should be fitted over the socket when the lamp fitting is removed. The lights, green starboard, red port, and white tail (white head, also, in the case of aircraft under way on water) should be kept clear and unobscured.

Navigation lights must be tested for illumination, alignment, and angle of visibility. If the illumination is doubtful the cause is probably poor electrical connection in the plug and socket fitting or the lamp may be aged. If all lamps show poor illumination it may be due to low voltage at the battery or to a bad switch contact. Navigation lights should always be fitted with the correct lamp bulbs, otherwise the required range of vision may not be obtained.

In craft of less than 65 feet span one or more lamps centrally situated may take the place of those here mentioned.

Identification Lamps and Switchboxes

The glasses of the lamps should be clean. Seating rings should be in good condition. Covers should be secured tightly by their clamps. The switchboxes should be maintained in good working order. Where applicable the key spring should be adjusted as required and the fulcrum of the morse key occasionally oiled with a drop of machine oil. The key contacts should be kept clean and flat; if the points become burned or pitted they should be cleaned with a fine file or emery paper. The switch contacts should be cleaned periodically by wiping with a vaselined rag.

Landing Flares

The ignition circuit must include a double-pole master switch or double-pole firing push buttons with long travel and guarded against accidental operation; or it must incorporate some other approved arrangement that will guard against accidental operation of the flares.

The wiring should be arranged to minimize the risk of its becoming energized by other circuits in the event of an accident.

The flares must be mounted upon proper brackets, the construction and position of which must be such that the glare will not interfere, directly or by reflection in the windscreen, with the pilot's vision, and that the flame will be prevented from overheating the wing or aileron fabric when the aircraft is in flight or standing on the ground. If necessary, metal sheathing must be used as a protective medium.

Flares should be examined for apparent swelling of the content, deterioration of the outer case, and entry of water or any foreign substance through the sealing compound of the fuse element at the top of the flare. An electrical continuity test should be made to ensure that the fuse is intact. Flares or igniters should not be used after the date specified thereon. Flares should be stored under suitable conditions when not in use and should be protected from weather, dampness, and undue heat. Before a flare which has been carried is returned to store, it should be wiped with a dry cloth. The practice of carrying an unused and unprotected flare in its bracket for any considerable period of time is inadvisable;

the effects of damp atmosphere and rain, especially under flying conditions, are harmful, and in an extreme case may result in either dangerously irregular burning or total failure upon attempts of ignition being made. Flares should not, therefore, be fitted to the aircraft until immediately before a particular flight upon which it is anticipated they will be required. Owing to the possibility of accidental ignition it is advisable that flare leads should be disconnected before placing the aircraft in an hangar.

Typical Landing Flare Bracket Used on Seagoing Aircraft

The landing flare bracket is designed to release the flare, when burning, just behind the actual landing point on the water, to avoid risk of the flare igniting oil or fuel under the machine when it comes to rest. The release is only a matter of seconds before landing. To fit the flare, insert the lugs into the contact holder, fit the hook of the wind vane on to the flare loop and pass the release strip through the slot in the guide and secure the end by the wing nut. When burning, the heat will release the strip from the flare, and the wind vane, kept in an upright position by wind pressure, will hold the flare. On losing speed the wind vane will drop forward until, before the machine actually lands, it drops sufficiently to release the flare from the bracket.

Care should be taken when testing these fuses not to use a lamp taking a greater current than .15 of an ampere, otherwise there is a danger of igniting the flare.

Landing Lamps

Are usually of a special design to suit a particular aircraft. They are, of course, on the accumulator circuit to prevent fading as the aircraft loses speed.

Lamp Fittings

The lighting arrangements should be kept clean. Lamp bulbs should be a good fit in their holders. Bulbs which show signs of blackening should be replaced.

Inspection Lamps

Examine the insulation of the wandering lead; the lead should be replaced if showing signs of abrasion.

Dimmer Devices

Where these are fitted, the rheostat should be tested for good contact between the switch arm and the resistance wire. A steady variation in light should be obtained as the dimmer is moved over its range of operation.

Heating Arrangements

Examine the apparatus for general condition. See that the elements are sound. Flexible leads should be in good condition with no signs of abrasion or stress at any of the plugs and socket fittings. The plugs and sockets should fit in a manner that will ensure good electrical contact. Devices which may be incorporated for preventing the accidental pulling apart of the connected plugs and sockets should be in good order. Any signs of over- or underheating should be immediately investigated. The surroundings adjacent to such heating arrangements should be adequately insulated against fire and scorching, and such insulation should be well maintained. No inflammable material may be within the vicinity and no

petrol or the like carried thereabouts whether in pipes, containers, or otherwise.

The various circuits should be tested separately for continuity. The current consumption of each section should be checked if any defect is suspected. If rheostats are incorporated they should be tested to ensure that heating can be reduced as required.

General Tests

The full electrical equipment must be in accordance with the aircraft maker's instruction and diagrams. The installation should be tested from time to time. The tests comprise Insulation, Resistance, Correct connections and continuity, and Functioning.

The results of all tests should be recorded. By logging such periodic tests any gradual deterioration of the insulation can be detected and steps taken to prevent a breakdown. Apparatus which is connected to the fixed wiring of the aircraft such as generators, portable lamps, heaters, etc., should be tested separately for insulation.

The minimum figure for such apparatus is one megohm, for generators a minimum of 40,000 ohms is acceptable. The test must be made with a 500 volt megger or other suitable instrument and the insulation resistance of all circuits must be tested between poles and between each pole and earth. The minimum results to be obtained are, for wire circuits—

$$\text{No. of megohms} = \frac{20}{\text{number of points in the circuit}}$$

The minimum value of the insulation resistance obtained by this formula is to be taken as 2 megohms. Switches (which must be closed in the circuit under test), terminal blocks, and other connected apparatus are to be counted as "points." The tests must be made with all switches in running position and the generators and batteries disconnected. All lamps must be removed from their sockets and all detachable plugs leading to heating units or other apparatus should be disconnected.

The insulation test in each instance must be maintained for not less than one minute.

(*Note.* Should the aircraft not be fitted with a voltage control box the leads stated will be found to be connected to a distribution terminal usually on or near the electrical control panel. The aircraft maker's appropriate diagram will indicate the position of this distribution terminal. The leads should be disconnected and the tests proceeded with as described.)

Test for Insulation Between Poles of all Battery Circuits

All leads normally connected to the red terminal of the voltage control box are brought together and connected to one pole of the megger, the other terminal being connected to the negative terminal at the voltage control box-blue. If the figure obtained as the result of this test is not satisfactory it will be necessary to separate the leads at the voltage control box and test each circuit separately until the faulty one is discovered. Action is then to be taken to trace and remedy the fault.

Test for Insulation Between Poles of the Generator Circuit

This test is similar to the foregoing except that the megger terminals are connected between the bunched leads from the yellow terminal and the bunched leads of the blue terminals of the voltage control box.

Test for Insulation Between Positives

This test is similar to that given "between poles" except that the megger terminals are connected between the bunched leads from the red terminal and the bunched leads from the yellow terminal of the voltage control box. It will be noticed that in this case the leads are components of different circuits and it will be impossible to arrive at a denominator for the formula; the figure 6 should therefore be assumed for the purpose.

Test for Insulation Resistance to Earth

For the purpose of this test all wires connected to all terminals of the voltage control box are bunched together and connected to one terminal of the megger; the other megger terminal is to be placed in good contact with the general earth system of the aircraft. If the result is unsatisfactory it will be necessary to separate the various circuits and test each separately until all faults are located and rectified. It will be understood that for the purpose of the first three of the above tests it is necessary temporarily to disconnect the various leads from the terminals of the voltage control box, which must not be in circuit during testing.

The insulation resistance will vary with atmospheric and other conditions and the standard obtained may be higher than that mentioned.

Testing for Correctness of Connections and Continuity

All wiring should be tested from point to point with a battery and lamp or bell, with suitable leads. The smaller sizes of cable should be placed under slight tension during the course of this test to separate possible broken parts which may be just touching.

Should this test indicate any fault it will not only be necessary to rectify it but the insulation tests must be repeated so far as the affected circuit is concerned.

Functioning Tests

An accumulator of suitable voltage should be temporarily connected to the normal accumulator leads and all switches and other control items on the normal accumulator branch operated several times to ensure that each branch of the system is working satisfactorily and is unaffected by the working of any other circuits; this will test the accumulator side. To test all circuits on both branches, the accumulator should be connected as for the battery branch, but in this case the generator leads should be disconnected at the generator end, and the plunger of the battery cut-out held up by hand. In this test all circuits on both branches should be operative.

General Remarks

Aircraft general electrical systems are Direct current; pressure is customarily limited to 14 volts to minimize fire risk and other dangers attendant upon the use of higher voltages; high current densities, however, occur, and care should be taken therefore that the size of all conductors is ample and that all joints are well made and have generous contact areas, otherwise heating will take place.

For reasons of the nature of the demand, to prevent whole or partial non-availability of essential lighting, etc., and to reduce the heavy discharge from one (the accumulator) in the case of slowing down or failure of the other (the generator) the load is derived from two sources—that of heating, etc., being the generator, and that of the navigation, signalling,

landing lights, etc., and any other service where continuity of supply is vital, being the accumulator. Generators, accumulators, wiring, conduits, runs, layouts, switch and fusing gear, electrolytes, insulation, joint boxes, protective treatment, or anything else should never be changed in type or anything added or taken away from the total system without reference to the aircraft maker. The compass is affected by the nearby presence of electrical apparatus and the possibilities of stray magnetic fields from apparatus or cables interfering with its correct functioning should be borne in mind. For example, the following are considered the minimum safe distances between the compass and such apparatus—

1. Kw. full load generator 6 feet; generator 500 watts full load 4 feet; generator 250 watts full load $3\frac{1}{2}$ feet; voltage regulator 40 amps. battery load $3\frac{1}{2}$ feet; twin cables carrying 40 amps. 1 foot; single cable carrying 40 amps. 8 feet; single cable carrying 20 amps. 6 feet; single cable carrying 10 amps. 4 feet.

Notices and signs concerning the electrical system should never in any circumstances be removed or obliterated.

No manner of work involving the shedding of metal filings, etc., the splashing of metallic paint, or the bestrewing of material which may act as a conductor of electricity, should ever be done in the vicinity of electrical gear without previously covering over such gear with a cloth, etc., which may be afterwards gathered and shaken clear of the aircraft.

Ample protection should be afforded all parts of electrical installation against water, petrol, oil, or spray.

(Figs. 71, 73-80, and 82 in this chapter are reproduced from *A.P.* 1095, by kind permission of the Controller, H.M.S.O.).

APPENDIX I

CERTIFICATE OF SAFETY FOR FLIGHT

I HEREBY CERTIFY that I have this day inspected the above aircraft (including its instruments and equipment but exclusive of the engine(s) and engine installation and of the instruments relating thereto) and that I am satisfied that it is safe in every way for flight, provided that the conditions of loading specified in the certificate of airworthiness are complied with.

The time this inspection was completed was 0900 hours.

Signed HERBERT BROWN.

Ground Engineer "A" Licence No. 10008.

Date: *November 30th, 1933* Time: 1030 hours.

(Extract from *Air Navigation Directions*)



APPENDIX II

Serial No. 745

ADVICE AND RELEASE NOTE
 Issued under Air Ministry Authority
 Reference No. 654321/30

Harry Jones's Aircraft Works, Ltd. NORTHEASTCHESTER ENGLAND

Telephone: 999

Telegrams: "AEROPLANES"

Please note the following have been dispatched—

Contract No.
 Order ref. No. ZA 313

Consignee—
 The Starland Aerial Transport Co., Ltd.
 Lowland Aerodrome,
 Nr. Highover,
 Hants.

Item No. of Contract or Order	Description of Goods including Part and Drg. Nos. and/or Speen. No.	Quantity	Identifica- tion	Remarks
5	STRUT. INTERPLANE 194/AC.531	1	4J21	Order Completo
12	PLATES, WIRING 2001/A3C 211	4	4J33	

CERTIFIED that the whole of the material and/or parts detailed hereon have been inspected and tested in accordance with the conditions of

The Air Navigation Directions

and the general requirements of the Director of Aeronautical Inspection and that they conform with the drawings and specifications relative thereto.

Signed K. N. RICHMOND,
 Chief Inspector, HARRY JONES'S AIRCRAFT WORKS, LTD.

Date : November 23rd, 1933.



APPENDIX III

(1) LIGHT ALLOYS

Material	Form	Specification	Base Alloying Metals	Composition, etc	Tensile Strength tons/sq. in.	Remarks	Used For
Duralumin	Sheet and strip	B.S.S. 3.L.3	Aluminium	Copper Manganese Magnesium	25	Bend radius = 2t. To be anodically treated	Hulls, floats, and fittings. Spars and ribs
"	Bar	B.S.S. 3.L.1	"	"	26	"	Machined fittings
"	Tubes	B.S.S. 3.T.4	"	"	7-8½	"	Fuselago and ribs
Aluminium	Sheet and strip	B.S.S. 2.L.16	"	None		Half hard. Bend radius = 1/2t.	Tanks and fairings
"	Bar	B.S.S. 3.L.4	"	"	5	Bend radius 1/2t.	Tank fittings
"	Tubes	B.S.S. 3.T.9	"	"	10	—	Pipe lines
Alclad	Sheet	D.T.D. 111	Duralumin—coated uniformly on both sides with pure aluminium	"	24	—	Hulls, floats, fittings, spars, and ribs
Alpax	Castings	B.S.S. L.33	Aluminium	Silicon	10½	For sea-going craft	Various fittings
Aluminium copper zinc alloy	Castings	B.S.S. 3.L.5	"	Copper zinc	9	For land machines	Various fittings
Aluminium copper alloy	"	B.S.S. 3.L.8	"	Copper	7	For unimportant parts	Various fittings

(2) STAINLESS STEELS

Material	Form	Specification	Base	Composition Alloying Metals	Tensile Strength tons/sq. in.	Remarks	Used For
12% Chromium steel	High tensile strip	D.T.D. 46A	Iron	Carbon Chromium	Max. stress not specified 0.1% proof stress = 65.	Bend radius = 3t for 24G and thinner material 5t for thicker material.	Spars and ribs
12% Chromium steel	Bar	B.S.S. S.62	"	Carbon nickel Chromium	46-52	Brinell hardness, No. 207-235	Machined fittings
12% Chromium steel	Tubes	D.T.D. 105	"	"	50	—	Struts
12% Chromium steel	Sheet	D.T.D. 23B	"	"	30-40	Bend radius = 1 1/2t.	Fittings
20% Chromium 2% Nickel steel	Sheet and strip	D.T.D. 60A	"	Carbon nickel Chromium	55	Hardened and tempered condition	Fittings
"	"	D.T.D. 146	"	"	40	Softened condition	Fittings
"	Bars	B.S.S. S.80	"	"	55	Brinell hardness, No. not less than 241.	Machined fittings
"	Tubes	D.T.D. 199	"	"	50	—	Struts
"	High tensile strip	D.T.D. 168	"	"	75	Bend radius = 3t.	Spars and ribs
18% Chromium 8% Nickel steel	Sheet and strip	D.T.D. 171A	"	"	35	Bond radii: for material thinner than 10G—closed down flat 10G, and thicker 1/2t.	Fittings. Hull plating.
"	Bar	D.T.D. 176A	"	"	35	—	Machined fittings
"	High tensile strip	D.T.D. 166	"	"	52-70	Bend radius = 1t.	Spars and ribs
"	Tubes	D.T.D. 207	"	"	35	—	Hull plating Struts

(3) PLAIN CARBON STEELS

Material	Form	Specification	Base	Composition Alloying Metals	Tensile Strength tons/sq. in.	Remarks	Used For
Mild steel	Sheet	B.S.S. 2.S.3	Iron	Carbon Manganese	28	Bend radius = 1/2t. Normal-size after welding.	Fittings
"	Bar	B.S.S. 3.S.1	"	"	35-45	"	Machined fittings
"	Tubes	B.S.S. 2.T.1	"	"	35	"	Struts
"	Castings	D.T.D. 17.A	"	"	26	"	Exhaust manifolds
"	Sheet	D.T.D. 12.A	"	"	22	Bend radius = 1t.	Streamline wires
Low carbon steel	Wires	B.S.S. S.W.3	"	"	52-65	Bend radius = 3t.	Streamline wires
High tensile steel							
Manganese steel	Castings	D.T.D. 9.B	(4)	VARIOUS STEELS Carbon Manganese	Not specified	Brinell hardness not less than 241	Skid shoes
Nickel chrome steel	Strip	D.T.D. 54.A	"	Carbon nickel Chromium	Not specified	Bend radii: 24G and thinner = 3t. Thicker than 24G = 5t	Spars and ribs
Nickel chrome steel	Tubes	B.S.S. 2.T.2	"	"	85-110	Must not be heated or drilled	For axles
Timed steel	Sheet	B.S.S. 3.S.20	"	Timed on surface	Not specified	Bend radius = flat	Tanks
High carbon steel for streamline wires and tie rods.							

(4) COPPER ALLOYS

Material	Form	Specification	Base	Composition Alloying Metals	Tensile Strength tons/sq. in.	Remarks	Used For
Copper	Sheet	B.S.S. 2.B.15	Copper	None	14-19	Bend radius— Closed down flat—Half hard	Tanks
Brass	Sheet	B.S.S. 2.B.16	"	Zinc	24-30	"	Tanks
"	Bar	B.S.S. 3.B.1.	"	"	35	"	Machined parts
Gunmetal	Castings	B.S.S. 2.B.2	"	Zinc and tin	16	"	Fittings
"	Bar	D.T.D 155	"	"	35	"	Machined parts
Monel metal	Sheet	D.T.D. 10.A	Nickel	Copper	30	Bend radius closed down flat	Tanks Float plating
MISCELLANEOUS							
Solder (Silver) hard	—	B.S.S. 206/1924	Silver	Copper and zinc	—	—	General
Solder soft	—	B.S.S. 219/1922	Lead Tin	—	—	—	General
Brazing metal	—	B.S.S. 263/1931	Copper	Zinc	—	—	General

APPENDIX IV

GLOSSARY OF AERONAUTICAL TERMS

Abstracted by permission from "British Standard Glossary of Aeronautical Terms," copies of which can be obtained from the British Standards Institution, 28 Victoria Street, London, S.W.1.

Airworthy. Complying with the prescribed regulations for a certificate of airworthiness.

Ground Engineer. An individual authorized to certify the safety for flight of an aircraft or parts thereof in accordance with the regulations for the time being in force.

Nose Heaviness. A tendency of an aircraft to pitch down by the nose in flight.

Tail Heaviness. A tendency of an aircraft to pitch down by the tail in flight.

Flutter. An unstable oscillation due to the interaction of aerodynamic and elastic forces upon the inertia of any structure.

Air Speed. Speed relative to the air, as distinct from speed relative to the ground.

Indicated Air Speed. The product of the air speed and square root of the relative air density (V_i).

Note. This definition will agree with readings taken by a pressure head only until the effect of compressibility becomes noticeable.

Range. The maximum distance an aircraft can travel under given conditions without refuelling.

Streamline. The path of a small portion of a fluid, assumed continuous, moving relatively to a solid body. The term is commonly used only of such paths as are not eddying, but the distinction should be made clear by the context.

Aeroplane. A flying machine with fixed wings.

Amphibian. An aeroplane provided with means for normally rising from and alighting on either land or water.

Landplane. An aeroplane provided with means for normally rising from and alighting on land.

Seaplane. An aeroplane provided with means for normally rising from and alighting on water.

Float Seaplane. A seaplane provided with floats as its means of support on water.

Flying Boat. A seaplane of which the main body or hull is also the means of support on water.

Monoplane. An aeroplane or glider with one main supporting surface.

Multiplane. An aeroplane or glider with two or more main supporting surfaces one above another.

Biplane, Triplane. *Note.* Monoplane, Multiplane, Biplane, and Triplane are also used as adjectives associated with a particular component, e.g. Biplane rudder, Triplane tail, etc.

Pusher Aeroplane. An aeroplane in which the airscrew is mounted in rear of the main supporting surfaces.

Ship-plane. Any aeroplane specially adapted for rising from and alighting on a ship's deck.

Tractor Aeroplane. An aeroplane in which the airscrew is mounted in front of the main supporting surfaces.

Aerofoil. A surface designed to produce an aerodynamic reaction normal to the direction of motion.

Slotted Aerofoil. An aerofoil having an air passage (or slot) rearwardly directed from its lower to its upper surface. This slot is so shaped that the portions of the aerofoil separated by it are themselves of aerofoil section. When the slot is forwardly located the portion forward of the slot forms an auxiliary aerofoil which may be rigidly attached to the rear portion or be capable of movement relative to it.

Slat. An auxiliary aerofoil forming the forward portion of a slotted aerofoil with forwardly located slot.

Aerofoil Section. The outline of the section of an aerofoil in a plane parallel to its plane of symmetry.

Aileron Angle, Elevator Angle, Rudder Angle. The angle between the chord of the movable portion of an aerofoil and the chord of the corresponding fixed surface.

Angle of Incidence (Rigging). The angle between the chord line of the main plane and the horizontal when the aeroplane is in the rigging position.

Note. Not to be confused with the true angle of incidence.

Angle of Sweep-back. The angular set back of the main planes relatively to the fuselage or hull.

Dihedral Angle. The angle at which both port and starboard planes of an aeroplane or glider are inclined upwards or downwards to the transverse axis. The dihedral angle is the acute angle between the span axis of either plane and the transverse axis. If the inclination is upwards the dihedral is positive.

Tail Setting Angle. The acute angle between the chord line of the main plane and the chord line of the tail plane. If the latter is at a greater inclination to the horizontal than the former the angle is said to be positive.

Camber. Curvature of a surface of an aerofoil.

Chord or Chord Length. The length of that part of the chord line which is intercepted by the aerofoil section.

Chord Line. The chord line is the straight line through the centres of curvature at the leading and trailing edges of an aerofoil section.

Gap. The distance between a plane and the one immediately above and below it.

Leading Edge. The forward edge of a streamline body or aerofoil. The structural member there situated.

Overhang. 1. The extent to which the wing tip of one of the two superimposed planes projects beyond the tip of the other.

2. The distance from the outer point of support to the tip of an aerofoil.

Rigging. The relative adjustment or alignment of the different components of an aerodyne.

Rigging Position. The position in which, with the lateral axis horizontal, an arbitrary longitudinal datum line is also horizontal.

Span. The overall distance from wing tip to wing tip.

Semi span. The distance from the tip to the plane of symmetry of an aerofoil.

Stagger. When one of two superposed planes is disposed ahead of the other, the planes are said to be staggered. When the top plane is ahead of the bottom the stagger is said to be positive.

Trailing Edge. 1. The rear edge of a streamline body or aerofoil.

2. The structural member there situated.

Wash-in. Increase of angle of incidence towards the wing tip.

Wash-out. Decrease in angle incidence towards the wing tip.

Airframe. An aeroplane with the engine(s) removed.

Doping. Treatment for the purpose of protecting tautening, strengthening or rendering airtight a surface.

Aero-structure. The supporting and controlling surfaces of a flying boat.

Ailerons. Movable flaps situated at or near each wing tip and designed to impart a rolling motion to the aerodyne by their rotation in opposite senses.

Floating Ailerons. Port and starboard ailerons so connected that, under the action of air moments, alone, they are free to take up an equilibrium without relative angular displacement. They are operated differentially in the normal manner through the control column.

Balanced Surface. A control surface which extends on both sides of the axis of the hinge or pivot in such a manner as to reduce the moment of the air forces about the hinge. The portion of the surface in the front of the hinge is referred to as the "balance" or "balance portion."

Horn Balance. The balance is confined to the tip of the control surface and extends beyond the fixed surface.

Centre Section. The central portion of the main plane (top or bottom).

Elevator. A movable horizontal surface for controlling the motion of an aerodyne in pitch.

Fin. A fixed vertical surface affecting the lateral stability of the motion of an aerodyne. When fitted at the rear end of the body it is termed the tail fin.

Flap. A hinge rear portion of an acrofoil.

Levers. Aileron Lever, Elevator Lever, Rudder Lever. The lever arm by which the control surface is connected to the actuating mechanism.

Planes. Main Plane. A supporting surface of an aerodyne, including ailerons.

Rudder. A movable vertical surface for controlling the motion of an aerodyne, in yaw.

Servo Control. A control devised to reinforce the pilot's effort by an aerodynamic or mechanical relay.

Stub Plane. 1. A short length of plane projecting from the fuselage or hull (usually forming a part thereof) to which the main portion of the plane is connected.

2. Projections from the hulls of flying boats to give lateral stability on the water.

Tail Unit. The combination of stabilizing and controlling surfaces situated at the rear of an aerodyne.

Chine. The extreme side member of the hull running approximately parallel to the keel in side elevation.

Control Column. The lever, or pillar supporting a hand wheel, by which the elevator and aileron controls are operated.

Adjusting Gear for Aileron, Rudder Fin, or Tail Plane. Mechanism provided for altering the trim of the control surface during flight.

Rudder Bar. The foot bar by means of which the rudder is operated.

Rudder Pedals. An alternative device to rudder bar.

Alighting Gear. That part of an aerodyne (other than the hull of a flying boat) provided for its support on land and water, and for absorbing the shock on alighting. In addition to the undercarriage, alighting gear includes subsidiary items such as tail skid, wing tip skids, and floats.

Float. A water-tight body giving buoyancy and stability on the water to a seaplane or amphibian and enabling it to take off and alight.

Flotation Gear. Emergency flotation appliances for landplanes.

Step. A break in the under-surface of a float or hull designed to facilitate take-off.

Tail Skid. A member taking the weight of the rear end of the fuselage on the ground.

Tail Skid Bar. The crosspiece on a steerable tail skid.

Tail Skid Shoe. A replaceable covering on the end of a tail skid to take the wear.

Tail Wheel. A small wheel sometimes fitted in place of a tail skid.

Undercarriage. That part of the alighting gear which embodies the main wheels, skids, or floats.

Acorn. A device introduced at the intersection of bracing wires to prevent abrasion.

Strut. A structural member intended to resist compression in the direction of its length.

Drag Struts. Struts incorporated in the framework of an aerofoil to carry the loads induced by the air forces in the plane of the aerofoil.

Interplane Struts. Vertical or inclined struts connecting the spars of a plane to those of the plane above.

Jury Strut. A strut inserted to provide temporary support for a structure. A common example is the strut used to support the wing structure of an aerodyne during folding.

Wires. *Drag Wires.* Wire or cables the principal function of which is to transfer the drag of the planes to the body or other part of the structure.

Anti-drag Wires. Wires to resist forces in the opposite direction to the drag.

Incidence Wires. Wires or cables bracing the main plane structure in the plane of a pair of front and rear struts.

Lift Wires. Wires or cable the principal function of which is to transfer the lift of the wings to the body or other part of an aerodyne.

Anti-lift Wires. Wires to resist forces in the opposite direction to the lift.

Flying Weight. The total weight of an aircraft at the beginning of a flight.

Gross Weight. The maximum flying weight of an aircraft permissible under the regulations obtaining.

Note. For Civil aircraft this is the maximum authorized weight shown on the Certificate of Airworthiness.

Tare Weight. The weight of an aerodyne complete in flying order with water in the radiators, but no crew, fuel, oil, removable equipment or payload.

Airscrews. 1. Generically, all types of screw with helical blades designed to rotate in air.

2. Specifically, a power driven screw designed to produce thrust by its rotation in air.

Pusher Airscrew. An airscrew designed to produce compression in the airscrew shaft.

Left-hand Airscrew. An airscrew revolving counter-clockwise to an observer behind the aircraft.

Right-hand Airscrew. An airscrew revolving clockwise to an observer behind the aircraft.

Note. In the tractor system the "hand" of the airscrew is the same as that of the engine, but in the pusher system it is the opposite.

Variable Pitch Airscrew. An airscrew whose blades are so mounted that they may be turned about their axis to a desired pitch while the airscrew is in rotation.

Note. This term is not to be used for an airscrew whose blades are adjustable only when stationary.

Blade Angle. The acute angle between the chord of an element of an airscrew blade and the plane of rotation.

Out-of-Pitch. Having the blade angles of one blade different from those of the other(s) at the same radius.

Boss. The central portion of the airscrew by which it is attached to the airscrew hub or shaft.

Diameter. The diameter of the circle described by the tips of the blades.

Disc Area. The area of the circle described by the tips of the blades.

Pitch. Experimental mean pitch. The distance through which an airscrew advances along its axis, during one revolution when giving no thrust.

Sheathing. Thin sheet metal or other material attached to the tips and leading edges of wooden blades to prevent abrasion by water, sand, etc.

Slipstream. The stream of air discharged aft by a revolving airscrew.

Spinner. A streamline fairing fitted co-axially and rotating with the airscrew.

Static Unbalance. An airscrew is in static unbalance if, when concentrically mounted on a spindle supported by knife edges, it will not remain at rest in all positions.

Torque. The moment about the airscrew axis of the air forces on the airscrew.

Windmill. A device which by virtue of its translational motion relative to the air rotates and so develops power.

Air Speed Indicator. An instrument, the reading on which, subject to certain corrections, gives the speed of the aircraft relative to the air.

Altimeter. An instrument graduated to indicate height under specified conditions.

Cross Level. An instrument for indicating the direction of the resultant force on an aircraft in a transverse plane.

Fore and Aft Level. An instrument for indicating the direction of the resultant force on an aircraft in its plane of symmetry.

Pressure Head. A combination of pitot and static pressure tubes for use in conjunction with a differential pressure gauge for determining the speed of a current of air.

Pitot Tube. A tube with an open end facing a current of air.

Static Pressure Tube. A tube with lateral apertures designed to ensure that the pressure in it shall be static.

Turn Indicator. An instrument for indicating the deviation of an aircraft from its course to port or starboard.

Compass. An instrument for indicating, subject to certain corrections, the angle in the horizontal plane between the true or magnetic meridian and the longitudinal axis of an aircraft.

Aircraft Landing Flare. A pyrotechnic flare normally attached to the underside of an aircraft to enable the pilot to illuminate the earth's surface when alighting.

Aircraft Lighting. The system of lighting on an aircraft.

Navigation Lamp. A lamp on an aircraft for indicating its position and direction of motion.

Riding Lamps. Lamps displayed by aircraft at anchor or when moored.

Signalling Lamp. A lamp for making visual signs.

Compass Base. An area provided with means for orientating aircraft to facilitate the compensation of their compasses.

Drogue. A sea anchor consisting of a conical sleeve, open at both ends, used to check the way of an aircraft.



APPENDIX V

THE LAW RELATING TO CIVIL AVIATION

By A. McISAAC

INTRODUCTORY—National Control of Flying—International Control of Flying—Control of Flying in Great Britain—Conditions of Flying—Compulsory Instruments and Equipment—Personnel and Log Books to be Carried—Rules for Air Traffic—Lights and Signals—Customs—Pilots' Licences—Navigators' Licences—Ground Engineers' Licences—Conclusion

Introductory

CIVIL aviation as a factor in the practical everyday life of any community can be said to have been non-existent prior to the Great War, 1914–1918. Any flying which took place before then—the first flight made by Wright, the crossing of the Channel by Blériot, and other flights in the various competitions and demonstrations that were held—can be looked upon as being of the nature of experimental or sports flying.

Immediately following the Great War there was a rapid and intensive development of the use of civil aircraft for the purpose of the public carriage of passengers and goods. From this point of view it may be admissible to look upon the year 1919 as that in which civil aviation as a practical means of transport actually had its birth.

It will be evident that this rapid development very soon rendered urgent the question of control of aviation. Such control can be exercised most effectively by the authorities responsible for the public business of any given community and in this country control is effected by means of Orders and Directions which are based on an Act of Parliament known as the Air Navigation Act.

In the following pages is given an outline of the main points in the law relating to civil aviation that will help the reader to a clearer understanding of those things with which he ought already to be acquainted. No attempt will be made to cover the whole field and it cannot be hoped that the study of the information given here could ever be accepted as a substitute for a study of the various Orders and Directions themselves. A full understanding of the matters involved can only be gained by the detailed study of the official pronouncements. It is useful to think of the very large body of motorists who serenely carry on without any accurate knowledge of the law relating to road traffic. The average motorist's knowledge of that law is confined to those little bits of information he acquires from reading press accounts of prosecutions under the Road Traffic Act, or, in some cases, by means of the more unpleasant way when he himself has been prosecuted and perhaps penalized. Despite the possible serious consequences arising from his ignorance, the motorist does not seem to think it worth while to make a personal study of the Road Traffic Act.

It may be that aviators as a body differ in this respect and do in fact know the provisions of the various air regulations, but in case this should not be so, the attempt is being made here to outline the main requirements that are peculiar to aviation. It should be borne in mind, however, that

League of Nations and is charged with the duties of modifying or amending the provisions of the Convention or its technical Annexes, the dissemination to the contracting States of information of every kind concerning international air navigation, and so on. Modification of the Convention or of its various technical Annexes is effected by means of Protocols, which likewise are subject to the ratification of the various countries subscribing to the Convention.

The subjects dealt with by this Convention are numerous and important. They include airworthiness, certification and registration, marking, personnel, equipment, customs, navigation, lights and signals, meteorology, traffic rules, and other matters connected with aviation which may have an international bearing.

Flying between any two States which are parties to the Convention is more or less straightforward and is governed by the requirements of the Convention itself. On the other hand, flying to or from a country which is not a contracting State may lead to difficulties and the aviator should make himself conversant with any other agreements or rules that may be in existence. Many agreements of such a bilateral nature exist; for example, that between Italy and Spain, and that between the United States of America and Canada.

It will be evident to the reader that international regulation is necessary if international flying is to be undertaken, but it may not be so evident that international requirements must reflect to a large extent the main points in the regulations of the various States. Quite naturally the international reacts back on the national, so that the tendency is towards a standardization of these requirements.

The Convention therefore sets out rules that are more or less in line with those existing in this country. Thus it is seen that aircraft must be registered and in possession of a valid certificate of airworthiness, the personnel (pilots, navigators, and engineers) must be licensed, prescribed log books must be carried, equipment as laid down must be fitted, and the aircraft must be operated in conformity with specific traffic rules and rules as to lights and signals.

The minimum requirements relating to the strength of aircraft have not yet been agreed internationally, and until such has been done these minimum requirements are determined by each of the contracting States according to their own ideas in the matter.

The qualifications required by licensed personnel is a matter on which agreement has been reached. We thus find in the Convention that pilots of private flying machines have to produce evidence of competency by undergoing practical flying tests whilst pilots of public transport machines have to undergo much more severe practical flying tests (including night flying) and to pass a technical examination on machines, engines, traffic rules, and elementary meteorology.

In the fields of meteorology, ground markings and lights and signals, we meet with those points on which international agreement is a *sho gun non*. Meteorology, for example, either from the point of view of its development as a science or that of its practical utilization for flying, is dependent on international co-operation. It is in these branches of the art of flying that the Convention lays down rules codified to the greatest extent.

A detailed examination of some of the requirements operating in Great Britain will be made later, and, as these to a very large extent are similar to the international requirements, no more need be said here regarding the Convention.

These licences remain valid, in the case of males, six months, in the case of females, four months, and are renewable. The fees payable are 5s. for the licence, £3 3s. for an official medical examination (10s. 6d. if the medical examination is for renewal), and, for technical examinations, £5 5s. in the case of first class and £2 2s. in the case of second class licences. The technical examinations in question take place in London usually about March and October each year.

Ground Engineers' Licences

Licences are issued to competent persons for the purpose of inspecting and certifying aircraft and aero-engines as safe for flight, and inspecting and certifying any repairs or replacements that may be made.

**A.N. Order,
Schedule II,
Para. 11**

These are known as ground engineers' licences and are classified in five categories—

- A. Inspection of aircraft before flight.
- B. Inspection of aircraft after overhaul.
- C. Inspection of aero-engines before flight.
- D. Inspection of aero-engines after overhaul.
- X. Other duties required to be performed under the Order (usually specialist duties, such as instrument repair and calibration, magnetto overhaul and test, parachute packing, and so on).

Applicants for these licences are required to be not less than 21 years of age, to have had satisfactory practical experience in the duties for which the particular licence is required, and to pass an examination. These licences remain valid for one year, can be extended, and are renewable. Where the ground engineer is constantly operative renewed licences can be made valid for two years.

**Schedule IV
A.N. Order.**

The fees payable are—

(a) For the issue of a licence—	
In one category	In each additional category
1 1	10
(b) For the extension of an existing licence—	
In a different category from that already held	
1 1	10
In the same category as that already held	
10	5
(c) For the removal of a licence	
If by examination	
1 1	10
If without examination	
10	10

The examinations, which are oral, are held in London weekly, in Croydon monthly, and in Manchester, Bristol, and Glasgow at three-monthly intervals. The qualifications required can be considered under the two headings, experience and knowledge.

The experience that is taken as satisfactory varies with the particular kind of licence required. Thus, for example, experience over a greater length of time may be required in the case of an "A" licence than in that of an "X" licence for parachute packing, whilst a still longer period might be required in the case of an "X" licence for instrument repair and calibration. For the main licences in respect of aircraft or engines, it can be taken that a minimum period of two years' practical experience will be necessary.

The knowledge required is likewise related to the particular kind of licence in question. Thus an applicant for an "A" licence is examined on the rigging and maintenance of aircraft and flying instruments; the applicant for a "C" licence on the daily maintenance and top overhaul of

aviators, like everyone else, are subject to numerous laws, the understanding of all of which would make one the complete lawyer. No attempt, therefore, will be made to deal with common law, insurance law, customs law, or any other of the various special laws that may be involved in aviation. Ignorance of the law cannot be pleaded as a defence in any proceedings, and it is the purpose of the following pages as far as possible to reduce ignorance of the law relating particularly to civil aviation.

National Control of Flying

Control of civil aviation in Great Britain and Northern Ireland has been effected through various Acts of Parliament, several of which were placed on the Statute Book between the years 1911 and 1919. As a result of the large development of civil aviation and other causes following the Great War, a new Act was passed including all the previous provisions, which Act is known as the Air Navigation Act, 1920.

Under the provisions of this Act, Statutory Rules and Orders are issued from time to time by His Majesty's Privy Council. The first of such Orders was the Air Navigation Order, 1922. This was superseded and cancelled by the Air Navigation (Consolidation) Order, 1923. Both the Air Navigation Act of 1920 and the Air Navigation (Consolidation) Order, 1923, are still in force.

Detailed administration of the Act is effected by means of the Air Navigation Directions, which are issued from time to time by the Secretary of State for Air.

Control is similarly effected in British Colonies and Protectorates by means of the Air Navigation (Colonies, Protectorates, and Mandated Territories) Order which differs from the Air Navigation (Consolidation) Order only in such respects as are required for the various local conditions. In turn, the Governments of the various Colonies issue Air Navigation Directions covering the detailed requirements of the Order.

Unlike the Colonies, the Dominions, with their own legislatures, have their own Acts, Orders, and Directions, which are independent of their British counterparts and only related thereto indirectly.

This consideration of national control leads naturally to the question of international control, which is dealt with in the following paragraphs.

International Control of Flying

International control of such things as shipping and communication (postal, telegraphic, wireless) is effected by means of various Conventions which have been the subject of discussion, negotiation, and agreement between the countries concerned. In the same way, aviation is controlled internationally by a Convention ratified by many countries. This Air Convention, dated in Paris the 13th October, 1919, was formulated and signed by plenipotentiaries of the signatory States. It came into force on the 11th July, 1922. The Convention has been ratified by most of the principal nations of the world, notable exceptions being Germany, Russia, Spain, and the United States of America.

The administration of this Convention is vested in a permanent Commission known as the Commission Internationale de Navigation Aérienne (C.I.N.A.) or, in this country, as the International Commission for Air Navigation (I.C.A.N.). This Commission, composed of representatives appointed by the contracting States, is placed under the direction of the

League of Nations and is charged with the duties of modifying or amending the provisions of the Convention or its technical Annexes, the dissemination to the contracting States of information of every kind concerning international air navigation, and so on. Modification of the Convention or of its various technical Annexes is effected by means of Protocols, which likewise are subject to the ratification of the various countries subscribing to the Convention.

The subjects dealt with by this Convention are numerous and important. They include airworthiness, certification and registration, marking, personnel, equipment, customs, navigation, lights and signals, meteorology, traffic rules, and other matters connected with aviation which may have an international bearing.

Flying between any two States which are parties to the Convention is more or less straightforward and is governed by the requirements of the Convention itself. On the other hand, flying to or from a country which is not a contracting State may lead to difficulties and the aviator should make himself conversant with any other agreements or rules that may be in existence. Many agreements of such a bilateral nature exist; for example, that between Italy and Spain, and that between the United States of America and Canada.

It will be evident to the reader that international regulation is necessary if international flying is to be undertaken, but it may not be so evident that international requirements must reflect to a large extent the main points in the regulations of the various States. Quite naturally the international reacts back on the national, so that the tendency is towards a standardization of these requirements.

The Convention therefore sets out rules that are more or less in line with those existing in this country. Thus it is seen that aircraft must be registered and in possession of a valid certificate of airworthiness, the personnel (pilots, navigators, and engineers) must be licensed, prescribed log books must be carried, equipment as laid down must be fitted, and the aircraft must be operated in conformity with specific traffic rules and rules as to lights and signals.

The minimum requirements relating to the strength of aircraft have not yet been agreed internationally, and until such has been done these minimum requirements are determined by each of the contracting States according to their own ideas in the matter.

The qualifications required by licensed personnel is a matter on which agreement has been reached. We thus find in the Convention that pilots of private flying machines have to produce evidence of competency by undergoing practical flying tests whilst pilots of public transport machines have to undergo much more severe practical flying tests (including night flying) and to pass a technical examination on machines, engines, traffic rules, and elementary meteorology.

In the fields of meteorology, ground markings and lights and signals, we meet with those points on which international agreement is a *sine qua non*. Meteorology, for example, either from the point of view of its development as a science or that of its practical utilization for flying, is dependent on international co-operation. It is in these branches of the art of flying that the Convention lays down rules codified to the greatest extent.

A detailed examination of some of the requirements operating in Great Britain will be made later, and, as these to a very large extent are similar to the international requirements, no more need be said here regarding the Convention.

Control of Flying in Great Britain

The aviator in Great Britain is essentially bound by the Air Navigation Act, 1930, the Air Navigation (Consolidation) Order, 1923,¹ and the Air Navigation Directions,² all as amended to date. The Air Navigation (Consolidation) Order will repay careful study from the point of view of the general conditions of flying and the Air Navigation Directions from the point of view of the technical requirements relating to machines and personnel.

In addition to these Orders and Directions, the Air Ministry frequently publishes Notices to Airmen which are of an explanatory or warning character.

It cannot be too strongly urged that all aviators should acquire a knowledge of the Orders and Directions. Without this knowledge infringements may be committed which may lead to serious penalties or consequences. It will suffice here to point out that any infringement of the regulations could lead to the imposition of a fine of £200 or to six months' imprisonment, or both. In addition to these penalties, circumstances may arise where licences may be suspended or cancelled, and, further, an aircraft may even be fired on if it is flown over a prohibited area.

Conditions of Flying

Perhaps the main requirements that must be met before a machine may fly are that—

- | | |
|------------------------|---|
| A.N. Order,
Art. 3 | (a) The machine must have a Certificate of Airworthiness and a Certificate of Registration; the pilot must be licensed; or |
| A.N.D. 11,
Para. 60 | (b) In the absence of the aforementioned certificates, the machine must have a permit to fly, in writing, from the Secretary of State for Air; or |
| A.N.D. 11,
Para. 60 | (c) The machine must be flown under special conditions outlined in the Air Navigation Directions known as the "A" or "B" conditions. |

The first two cases mentioned above are self-explanatory. The case at (c), however, requires some explanation. Formerly it was permissible for unlicensed or unregistered aircraft to be flown provided that the flight took place within three miles radius of a recognised aerodrome. This very elastic condition was open to serious abuse and is no longer in force. The "A" or "B" conditions are designed to allow the same or even greater latitude under proper safeguards. Briefly stated, the "A" conditions permit the flying of an aircraft without a certificate of airworthiness provided that the flight is a *bona fide* test flight under authorised supervision for the purpose of the issue or renewal of a certificate of airworthiness; the "B" conditions relate to experimental flying in such a way that certain people, including most of the established aeroplane constructors, are authorised to fly anywhere in the country machines which are neither registered nor certified as airworthy, the only requirement being that the machines, if not already registered and bearing the normal registration marks, bear a distinguishing mark which is allotted to each such authorised person to show that the machines are being flown under these conditions.

A.N. Order, Schedule I	The Certificate of Registration for any aircraft (fee, £1 1s.) lasts indefinitely and depends only on the continuation of ownership of the machine by one individual.
---------------------------	---

¹ The Air Navigation (Consolidation) Order, 1923, published by H.M.S.O. at 1s. 3d.

² The Air Navigation Directions, 1932 (A.N.D. 11), published by H.M.S.O. at 9d.

The Certificate of Airworthiness lasts for one year and is renewable, the fee for initial issue (in the case of "subsequent" aircraft) and for renewal being £5 5s. on each occasion.

The issue of a certificate of airworthiness for a new type of aircraft depends on official approval of design, official inspection of construction and official flying trials.

A.N. Order,
Schedule II

It is to be noted here that the modification of an existing aircraft likewise requires official approval of design and official inspection, but official flying trials are not always required in such cases.

A.N.D. 11,
Para. 36

The fees payable for a "type" certificate of airworthiness vary with the tare weight of the machine and are specified in the Air Navigation Order.

The issue of a certificate of airworthiness for a subsequent aircraft (i.e. a replica of a type already approved) follows a recommendation made by approved constructors or, where the constructor is not approved for the purpose of such recommendations, by the Aeronautical Inspection Directorate, Air Ministry.

A.N. Order,
Schedule II,
Para. 2

Aircraft are always certified as airworthy (i.e. a certificate of airworthiness is issued) in one or more of three categories: "Normal," "Acrobatic,"

A.N.D. 11,
Paras. 37 & 38

"Special"; and in one or more of a number of subdivisions as: "Subdivision (a), Public Transport for Passengers," "Subdivision (d), Private," "Subdivision (f), Racing or Record." It is the responsibility of the pilot to see that the machine is not used for any purpose for which it is not certified.

Renewal of the certificate of airworthiness if dependent on the inspection and recommendation of an authorised inspector. "Hire and Reward"

A.N. Order,
Schedule II,
Para. 3

machines (i.e. machines engaged regularly in what is best described for this purpose as fare-paying passenger carrying) are inspected and recommended for renewal by the Aeronautical Inspection Directorate. All other machines are inspected and recommended for renewal by the Joint Aviation Advisory Committee, which is an organisation composed of two older bodies, Lloyd's Register and the British Corporation Register of Shipping and Aircraft. The Joint Aviation Advisory Committee has been specially approved by the Air Ministry for such activities. It will be noted from the foregoing that a subsequent machine may be built, certified as airworthy and its certificate of airworthiness renewed without any official intervention.

There are other general conditions of flying, amongst which may be mentioned the following—

A.N. Order,
Art. 4

A flying machine may not land in nor fly over any prohibited area at a lower altitude than 6,000 ft. The prohibited areas are defined in the Order.

A.N. Order,
Art. 15

Every flying machine must carry the prescribed documents. In all cases these include the certificates of airworthiness and registration and a journey log book kept up to date.

A.N. Order,
Art. 13

Dropping of articles from aircraft in flight is strictly prohibited except in the case of ballast allowed by the Order, i.e. fine sand or water, or as permitted in writing by the Secretary of State.

**A.N. Order
Art. 9** An aircraft may not be flown over any city or town except at such an altitude as will enable it to land outside the city or town without means of propulsion.

An aircraft must not be used to carry out any trick flying or exhibition flying over any populous area or over any concourse of people, such as a regatta or a race meeting, without the written permission of the promoters, nor may it be flown at such a low altitude as to cause unnecessary danger to persons or property.

**A.N. (Amendment) Order,
1933** An aircraft may not be used for wing-walking or any other such exhibition purpose for which the structure has not been designed, unless permission in writing for such purpose has been obtained from the Secretary of State.

**A.N. Order,
Art. 14** Every aircraft must carry the prescribed instruments which must be maintained in working order.

**A.N. Order,
Art. 18** An aircraft engaged on international flying must not be used for the carriage of explosives, arms, or munitions of war.

**A.N. Order,
Art. 22 and
Schedule VIII** Every aircraft flying to or from this country must land at or take off from a Customs aerodrome and must pass between such points as may be prescribed.

The foregoing conditions are applicable in all cases, but in addition to these there are certain further conditions applicable to hire and reward machines. These include the following—

Any aircraft plying for hire and reward is not permitted to fly unless it has within twenty-four hours been inspected and certified as safe for flying. This inspection and certification must be made

**A.N. Order,
Schedule II** by licensed ground engineers. The certificate, which lasts for twenty-four hours, is made out in duplicate,

one copy being carried in the journey log book and one copy retained by the owner for six months.

The pilot of any such hire and reward machine must satisfy himself that the aircraft is satisfactorily loaded for safety in flight.

For the purpose of so satisfying the pilot in the case of any flying machine which may be employed on a regular line or service of public air transport, a load sheet containing the prescribed particulars must be completed and submitted to the person in charge of the aircraft. This load sheet must be kept by the owner of the aircraft for six months.

Compulsory Instruments and Equipment

The pilot of an aircraft is responsible for seeing that it is furnished with the prescribed instruments and equipment. What these must be depends on the classification of the machine and the purpose of the given flight. The main points to be remembered in this connection are set out in tabular form opposite.

**A.N. Order,
Schedule II,
Para. 9** It will be seen that certain equipment is essential in all machines during all flights and that the additional compulsory equipment can readily be ascertained for flights in the special circumstances enumerated.

Personnel to be Carried

In addition to any other specified members of the crew, every flying machine used for the international carriage of passengers or goods for hire

or reward must carry a navigator with first or second class licence if flying—

A.N.D. 11, Para. 78 more than 100 miles over inhabited regions or more than 100 but not more than 625 miles over the high seas or uninhabited regions or, by night, more than 16 miles but not more than 625 miles.

In the same circumstances a navigator with a first class licence must be carried if the machine is flying—

A.N.D. 11, Para. 79 more than 625 miles over the high seas or uninhabited regions or, by night, more than 625 miles.

In certain circumstances the pilot who holds the necessary navigator's licence may, even if he is alone on board, fulfil the duties of navigator in the former case.

	Classification of Aircraft	Nature of Flight	Compulsory Instruments and Equipment
A.N.D. 11, Para. 23	All flying machines	All flights	Air speed indicator Altimeter Revolution indicator, and Such gauges as are considered essential (usually approved as a part of the type design of the aircraft) Safety belt for each person in an open cockpit and for the pilot(s) whether in open cockpits or not
A.N.D. 11, Para. 63	All flying machines	Flight by night	Navigation lights Illumination for instruments and equipment
	Amphibian flying machines	All flights	Indicator of position of landing wheels
	Hire and reward flying machines	All flights	Fire extinguisher (if 10 or more seats are fitted, one for each main compartment, with a minimum of two extinguishers) Wireless apparatus (if 10 or more seats are fitted)
	Hire and reward flying machines	Flights extending beyond 20 miles from point of departure	Compass Watch Turn indicator (if more than 5 seats are fitted)
	Hire and reward flying machines	Flights at any point of which the machine is more than 10 miles from land	Lifebelt for each person on board
	Hire and reward flying machines	Flight by night	Landing lights (lamps or wing-tip flares)

Log Books

Every aircraft must carry a journey log book. In addition every aircraft engaged in hire and reward flying must be provided with an aircraft

A.N.D. 11,
Sect. X

log book and an engine log book for each engine. Where aircraft and engine log books are not compulsory, a suitable book is to be kept in which repairs, replacements, and like matters may be recorded.

Rules for Air Traffic

A.N. Order,
Schedule IV,
Para. 21

Flying machines (i.e. power-driven heavier-than-air craft) must always give way to airships and to balloons whether fixed or free.

The rules regarding risk of collision between power-driven aircraft may be summarised as follows—

A.N. Order,
Schedule IV,
Paras. 26 *et seq.*

When two aircraft are meeting end on, or nearly end on, each must alter its course to the right.

When two aircraft are on courses which cross, the aircraft which has the other on its own right side must keep out of the way of the other.

An aircraft overtaking another must keep out of the way by altering its own course to the right and must not pass by diving.

Every aircraft following an air traffic route, which has been officially recognised, must keep such route at least 300 yards on its left.

These may be said to be the main points to be observed whilst in flight and away from the aerodrome. There are many other points involved whilst the machine is at, leaving, or approaching the aerodrome. As these do not lend themselves to simplified description and as any failure in their observance might involve litigation or other heavy expenses in connection with third party damages or insurance, the interested reader is advised to refer directly to the appropriate section in the Air Navigation Order.

Lights and Signals

Navigation lights are compulsory for all aircraft flying by night. The lights to be shown are as follows—

A.N. Order,
Schedule IV,
Sect. 1 (A)

On the right side: a green light,

On the left side: a red light,

At the rear: a white light,

all of which lights are to be visible over a prescribed distance and in prescribed angles.

If the maximum span of a flying machine is less than 65 ft., one lamp placed centrally and combining these three requirements may be used.

In addition to the lights mentioned above, every flying machine which is under way on the surface of the water, under control and not being towed, is required to display a white light to show forward and be visible at a prescribed distance and in a prescribed angle.

An aircraft wishing to land at night on an aerodrome having ground control must make intermittent signals either with a lamp or projector

A.N. Order,
Schedule IV,
Sect. II

other than the navigation lights, or with any sound apparatus. In addition it must signal in Morse code by the same means the two-letter group composed of the first and last letters of its five-letter registration mark.

Permission to land will be given by the same two-letter sign from the ground in green light, followed by intermittent signals of the same colour.

The firing of a red light or the display of a red flare from the ground is to be taken as an instruction that the aircraft is not to land.

An aircraft compelled to land at night must, before landing, make with its navigation lights a series of short and intermittent flashes.

Customs

Any aircraft going abroad or coming from abroad must leave or land at a Customs aerodrome, and, in addition, must cross the frontiers between specified points. Where circumstances beyond the control of the pilot force it to cross frontiers elsewhere, the machine must be landed at the nearest Customs aerodrome, and if it is forced to land before reaching such an aerodrome, the pilot is required to report the matter immediately to the nearest police or Customs authorities. In either case the machine may leave again only with the permission of these authorities.

A.N. Order,
Schedules VIII
and IX

In every case of export, the consignors are required to make a detailed Declaration of the goods in question, and, in addition, a Manifest or general declaration of cargo is to be provided for each such journey of every aircraft. Both these forms are prescribed by the Commissioners of Customs and Excise.

Clearance by the Customs authorities is required before the aircraft may leave a Customs aerodrome and for this purpose the pilot has to produce to the Customs officer—

- (a) The Journey Log Book,
- (b) The Manifest and Declaration mentioned above, and
- (c) An application for clearance on a prescribed form in which is to be stated the Customs aerodrome or aerodromes at which it is intended to land.

These documents, when signed and stamped by the Customs Officer, constitute the clearance.

On landing at any Customs aerodrome from abroad, the pilot is required to make a report to the Customs Officer, produce the journey log book, manifest and declaration of cargo properly cleared at departure, and to land all passengers for examination of baggage. Unloading of goods may not be commenced until this report has been made and the authority of the Customs Officer obtained.

Pilots' Licences

Licences for pilots of flying machines are of two kinds —the "A" licence, which is required by a pilot of a private machine, and the "B" licence, which is necessary before a pilot may fly a machine for hire and reward.

Licences may be obtained at any time, there being no fixed periods or places at which tests or examinations are to be undertaken.

"A" licences remain valid for twelve months and are renewable. The fee payable is 5s., but a further £1 1s. is payable if an official medical examination is needed and another £1 1s. if an official flying test is required. Proofs of competency, medical fitness, and recent flying experience are called for. These requirements are usually met by submitting a certificate as to competency, obtained from the Royal Aero Club, and a certificate as to medical fitness made out on C.A. Form 61 by a duly qualified medical practitioner. Three hours solo flying experience during the preceding twelve months is required before such a licence is issued or renewed.

"B" licences remain valid in the case of males for six months and in the case of females for four months, and are renewable. The fees payable are 5s. for the licence, 5s. for a technical examination, £3 3s. for an official medical examination (10s. 6d. if the medical examination is for renewal), and £10 for an official flying test (if required).

Proofs of competency, medical fitness, and recent flying experience are called for. With regard to competency, the applicant must be possessed

of an "A" licence or undergo the tests required in that case, and, further, undergo the following tests—

A left-hand and right-hand spin.

Two cross-country or oversea flights of at least 200 miles each, during one of which a height of at least 6,500 ft. above the point of departure must be maintained for at least one hour, and including two landings (at points fixed beforehand by the examiners) and terminating with a landing at the point of departure.

A night flight of at least 30 minutes made between two hours after sunset and two hours before sunrise at a height of at least 1,500 ft. above the ground.

A cross-country or oversea flight of at least 200 miles with an examiner on board, and including three forced landings at points selected by the examiner.

General flying for about half-an-hour with an examiner on board and including five landings.

For the two latter tests the flying machine is provided by the Secretary of State.

The technical examination is designed to elicit that the candidate has a satisfactory knowledge of the general construction, functioning and assembly of the aircraft and aero-engines concerned, of his knowledge of rules as to lights and signals, general and special rules for air traffic, and elementary meteorology.

With regard to medical fitness, special examinations are conducted by specially appointed medical officers under the authority of the Secretary of State, and it is to be noted that this medical examination must be undergone before a licence is renewed, after illness or accident, or when a licence holder has performed a total of 125 hours flying as a pilot within any period of 30 consecutive days.

Flying experience amounting to 100 hours as pilot in sole charge of a flying machine, including at least 30 landings, during the preceding two years is required before such a licence is issued. For renewal it is necessary to produce proof of reasonable flying experience during the preceding six months.

Navigators' Licences

Navigators' licences are of two kinds, known as first class and second class. The applicant for a second class licence is required to be competent

A.N.D. 11, in the theory and practice of the calculation of course
Para. 103 and distance, the reading of maps and charts, compasses,
flight by dead reckoning, navigation by radiogoniometry,
international air legislation, signalling, and meteorology.

In addition he is required to have had at least two years' air experience during which he must have spent at least 300 hours as an operative member of the crew of an aircraft in flight.

The applicant for a first class licence is required to have a more advanced knowledge of the subjects already indicated, and also of tides and astronomical navigation. In addition, he must have had four years air experience during which he must have spent at least 600 hours as an operative member of the crew of an aircraft in flight, including 100 hours navigating in the air and not less than 15 hours night flying.

In both cases a medical examination, to the same extent and under the same conditions as apply to class "B" pilots' licences, is required to be undergone before the issue or renewal of a navigator's licence.

These licences remain valid, in the case of males, six months, in the case of females, four months, and are renewable. The fees payable are 5s. for the licence, £3 3s. for an official medical examination (10s. 6d. if the medical examination is for renewal), and, for technical examination, £5 5s. in the case of first class and £2 2s. in the case of second class licences. The technical examinations in question take place in London usually about March and October each year.

Ground Engineers' Licences

Licences are issued to competent persons for the purpose of inspecting and certifying aircraft and aero-engines as safe for flight, and inspecting and certifying any repairs or replacements that may be made. These are known as ground engineers' licences and are classified in five categories—

A.N. Order,
Schedule II,
Para. 11

- A. Inspection of aircraft before flight.
- B. Inspection of aircraft after overhaul.
- C. Inspection of aero-engines before flight.
- D. Inspection of aero-engines after overhaul.
- X. Other duties required to be performed under the

Order (usually specialist duties, such as instrument repair and calibration, magneto overhaul and test, parachute packing, and so on).

Applicants for these licences are required to be not less than 21 years of age, to have had satisfactory practical experience in the duties for which the particular licence is required, and to pass an examination.

These licences remain valid for one year, can be extended, and are renewable. Where the ground engineer is constantly operative renewed

A.N. Order,
Schedule IV

licences can be made valid for two years.
The fees payable are—

	£	s.	d.
(a) For the issue of a licence—			
In one category	1	1	—
For each additional category		10	—
(b) For the extension of an existing licence—			
In a different category from that already held	1	1	—
In the same category as that already held			
if by examination		10	—
if without examination		5	—
(c) For the renewal of a licence			
If by examination	1	1	—
If without examination		10	—

The examinations, which are oral, are held in London weekly, in Croydon monthly, and in Manchester, Bristol, and Glasgow at three-monthly intervals.

The qualifications required can be considered under the two headings, experience and knowledge.

The experience that is taken as satisfactory varies with the particular kind of licence required. Thus, for example, experience over a greater length of time may be required in the case of an "A" licence than in that of an "X" licence for parachute packing, whilst a still longer period might be required in the case of an "X" licence for instrument repair and calibration. For the main licences in respect of aircraft or engines, it can be taken that a minimum period of two years' practical experience will be necessary.

The knowledge required is likewise related to the particular kind of licence in question. Thus an applicant for an "A" licence is examined on the rigging and maintenance of aircraft and flying instruments; the applicant for a "C" licence on the daily maintenance and top overhaul of

aero-engines and all instruments and equipment related thereto in the aircraft; the applicant for a "B" or "D" licence is examined on the construction of the complete aircraft or engine respectively from raw material to finished product, including workshop processes, heat treatments, and, in the case of the "D" category, engine testing.

A syllabus of the examination is issued to each applicant showing the subjects dealt with in each separate category, and it will be seen therein that for all categories a knowledge of the Air Navigation Order and Directions is required. This is important from the point of view of the duties and responsibilities to be undertaken by ground engineers. An "A" licence authorizes its holder to certify as safe for flight the aircraft named in his licence and to replace parts or components which have already been approved and require assembly only, but it does not permit him to certify any repair work involving workshop processes on the same machine; whilst a "B" licence holder, though authorized to certify such repair work, or even the complete construction of the machine, is not permitted to certify it as safe for flight. In the same sense, a "D" licence holder can certify the complete overhaul and testing of an aero-engine but no one who is not the holder of a "C" licence can certify that the engine is properly installed and functioning correctly in an aircraft and is safe for flight.

Ground engineers must never issue certificates unless their licences clearly cover the matériel in question. Thus a person who holds an "A" licence valid for an aircraft but excluding compass, turn indicator, and electrical services, should not "sign out" a machine in respect of any flight for which these are compulsory.

Being in a position of trust, the ground engineer is frequently appealed to by owners for guidance as to the regulations. In any case, he himself must know the steps that must be taken to ensure the embodiment of compulsory modifications and the use of nothing but approved materials, the equipment and instruments that must be fitted in varying conditions of flight, the kinds of log books that must be carried, the kinds of certificates that must be issued by him, and other matters that are all additional to his "trade" knowledge. It is, therefore, clear that a knowledge of the Order and Directions is imperative in so far as they are concerned with ground engineering, inspection and conditions of flight.

Conclusion

These then are the main points in the law relating to civil aviation. It is not, however, to be taken that these constitute a complete statement in the matter, but it is felt that the grouping, arranging and wording adopted here are altogether suitable as an explanation or as a reminder to the reader.

There are other points which have not been dealt with because the circumstances in which they arise are infrequent. For example, the use of wireless on aircraft and the compulsory equipment that is required for making the prescribed signals when night flying or when inadvertently flying over a prohibited area. The use of wireless apparatus on aircraft is highly specialized, and is, in fact, a complete subject in itself, whilst the signalling equipment mentioned varies with the circumstances of the case.

This statement on the law relating to civil aviation might have been concluded with a list of "Don'ts" addressed to pilots, ground engineers, or operators generally. Perhaps, however, this is best left to the reader and he or she, whether engaged as pilot or ground engineer, is strongly urged to study the sections herein dealing with the activities in which he may be engaged and to construct such a list of "Don'ts" for himself.

