

# MINERAL OILS

AND THEIR

BY-PRODUCTS

# MINERAL OILS

AND THEIR

BY-PRODUCTS

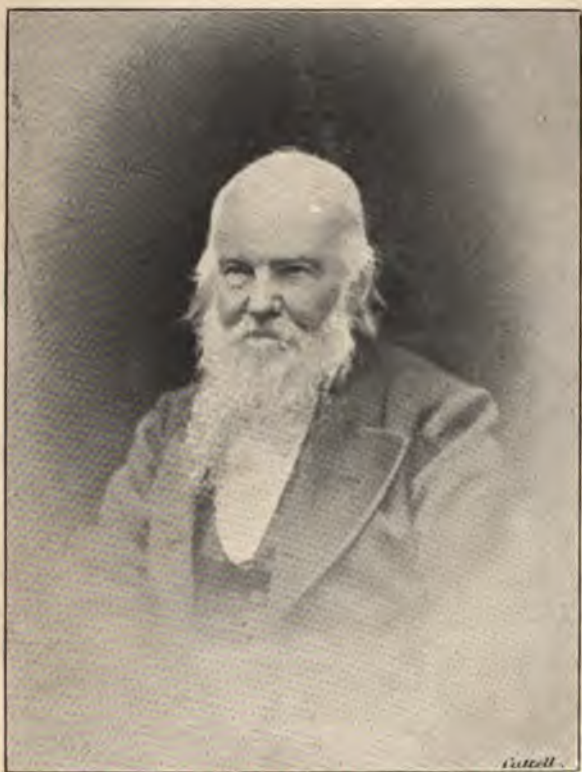

THE LATE JAMES YOUNG, ESQ.

PIONEER OF THE MINERAL OIL TRADE

A PRACTICAL TREATISE  
ON  
MINERAL OILS  
AND THEIR  
BY-PRODUCTS

INCLUDING

A SHORT HISTORY OF THE SCOTCH SHALE OIL INDUSTRY,  
THE GEOLOGICAL AND GEOGRAPHICAL DISTRIBUTION  
OF SCOTCH SHALES, RECOVERY OF ACID AND  
SODA USED IN OIL REFINING,

AND

*A LIST OF PATENTS RELATING TO APPARATUS AND PROCESSES  
FOR OBTAINING AND REFINING MINERAL OILS*

BY

ILTYD I. REDWOOD

ASSOCIATE MEMBER AMERICAN SOCIETY OF MECHANICAL ENGINEERS;  
MEMBER SOCIETY OF CHEMICAL INDUSTRY (ENGLAND);  
AUTHOR OF 'THEORETICAL AND PRACTICAL AMMONIA REFRIGERATION'



NEW YORK  
PUBLIC  
LIBRARY

London:  
E. & F. N. SPON, LIMITED, 125 STRAND  
New York:  
SPON & CHAMBERLAIN, 12 CORTLANDT STREET  
1897

P.V.

THE NEW YORK  
PUBLIC LIBRARY  
72321  
ASTOR, LENOX AND  
TILDEN FOUNDATIONS.  
1897.

NY Y V 34  
JUN 4  
1911

THE AUTHOR

**Dedicates this Book**

TO THE MEMORY OF HIS GREATLY-ESTEEMED FRIEND

**ALEXANDER LUMSDEN**

MINING ENGINEER



## P R E F A C E.

---

THE local importance of the Scottish Shale Oil Industry has received recognition in practical treatises on petroleum, and in the most recent of such works particulars are given of the processes of manufacture which have been successively adopted. There is, however, so much that is instructive in the hitherto unpublished details of the development of an industry in which, under the stimulus of keen competition, remarkable technical skill has been exhibited, that the Author has been encouraged to attempt to deal with the subject more fully than there has been opportunity for in works of a comprehensive character. In former years the Author felt the want of such a source of information as that which he has endeavoured to supply, and he therefore ventures to hope that the result of his labour will be found of value not only by those who are about to become actively engaged in the industry, but also by the large number who are already directly or indirectly interested in it.

The Author feels greatly indebted, and wishes to express his thanks, to many friends and strangers



who supplied him with historical and other information, and more especially to his colleagues, Messrs. JOHN GALLETLY and the late ALEXANDER LUMSDEN, who most generously placed information regarding apparatus, &c. (in use before the Author was connected with the trade) at his disposal.

BROOKLYN, 1897.

# CONTENTS.

CHAPTER	PAGE
I. HISTORICAL . . . . .	1
II. GEOGRAPHICAL AND GEOLOGICAL . . . . .	38
Shale . . . . .	41
III. THEORETICAL . . . . .	46
IV. PRACTICAL . . . . .	54
Retorts . . . . .	57
Refining . . . . .	110
Distilling . . . . .	110
Treating . . . . .	125
Treatment and Distillation of Oils in various stages . . . . .	131
Pressing . . . . .	146
Wax Refining . . . . .	160
V. AMMONIA WATER . . . . .	169
Use and Impurities of Sulphate of Ammonia . . . . .	170
Sulphate of Ammonia Manufacture . . . . .	171
Ammonia Still . . . . .	173
Cracker Boxes . . . . .	176
Settling Tanks . . . . .	178
Evaporating Boxes . . . . .	179
Working Details . . . . .	179
Chemistry of Sulphate of Ammonia Manufacture . . . . .	183
VI. DISTILLING DATA . . . . .	191
Pressure Stills . . . . .	195
Continuous Distillation . . . . .	198
Condensers . . . . .	199
VII. TREATING DATA . . . . .	203
Air <i>versus</i> Mechanical Agitation . . . . .	203
Recovered Acid . . . . .	205
Soda Recovery . . . . .	206

x *MINERAL OILS AND BY-PRODUCTS.*

CHAP.	PAGE
VII. TREATING DATA— <i>continued.</i>	
Soda Tars . . . . .	206
Soda Coke . . . . .	210
Treatment of Waste Water from the Works . . . . .	210
VIII. LABORATORY . . . . .	214
Solidifying Point . . . . .	214
Setting Point . . . . .	215
Relation between Cold Test and Percentage of Wax . . . . .	217
Flash Point . . . . .	218
Viscosity . . . . .	220
Melting Point . . . . .	223
Oil in Wax . . . . .	228
Dirt in Wax . . . . .	228
Water in Wax . . . . .	229
Burning Oil . . . . .	229
Compounded or Mixed Oils . . . . .	230
Testing Ammonia Water . . . . .	233
Testing Sulphate of Ammonia . . . . .	234
Sulphate of Ammonia Liquor . . . . .	235
Determination of Boiling Points . . . . .	236
Purification of Crude Oil . . . . .	237
Reporting Results . . . . .	245
Distillation <i>versus</i> Treatment . . . . .	248
Difference between Laboratory and Works Results . . . . .	249
Analyses of Coke, Gas and Sacking . . . . .	249
Specific Gravity of Waxes . . . . .	250
Chrysene . . . . .	251
Extraction of Phenols . . . . .	253
Extraction of Oily Bases . . . . .	256
Preparation of Normal Paraffins . . . . .	257
Comparison of Specific Gravity, Beaumé & Twaddell . . . . .	261
PATENTS RELATING TO THE SCOTCH MINERAL OIL	
INDUSTRY :—	
INDEX OF SUBJECTS AND PATENTEES . . . . .	263
PATENTS . . . . .	269
INDEX . . . . .	326

## ILLUSTRATIONS.

FIG.		PAGE
1	General Plans of Retorting Department . . . . .	54
2	Shale Breaker . . . . .	56
3	Bell's Retort . . . . .	60
4	Cowan's „ . . . . .	60
5	Large-sized D Retort . . . . .	60
6	Setting for Horizontal Retorts . . . . .	61
7	Front sectional view, Kirk's Vertical Retort . . . . .	65
8	Side „ „ „ . . . . .	65
9	McBeath's Retort . . . . .	70
10	Side sectional view, Henderson's Retort . . . . .	72
11	Plan of Henderson's Retort . . . . .	73
12	Side sectional view, Beilby's Retort . . . . .	82
13	Young and Beilby's Shale Retorts, front view partly in section . . . . .	85
14	„ „ side section . . . . .	87
15	„ Coal Retort, side section . . . . .	88
16	End elevation of Air Condenser . . . . .	95
17	Plan „ „ . . . . .	95
18	Side elevation „ „ . . . . .	95
19	Section of Separator . . . . .	98
20	Plan „ . . . . .	98
21	Cheap form „ . . . . .	99
22	Coke Tower, partly in section . . . . .	100
23	„ Apparatus, general plan of . . . . .	101
24	„ „ elevation of . . . . .	103
25	„ „ Naphtha Condenser . . . . .	105
26	„ „ Still elevation . . . . .	105
27	„ „ „ plan . . . . .	105
28	„ „ Heater . . . . .	105
29	Cooling Pond for Spent Shale . . . . .	109

FIG.		PAGE
29A	First forms of Stills . . . . .	111
30	Side section of Crude and Heavy Oil Still . . . . .	113
31	"    Burning Oil Still . . . . .	120
32	End "    " . . . . .	120
33	Plan of "    " . . . . .	120
34	Plan of Worm House . . . . .	122
35	End section " . . . . .	122
36	Centrifugal Stirrer and Agitator . . . . .	127
37	Acid Egg in section . . . . .	129
38	Gasoline Still . . . . .	144
39	Young's Cooling Drum . . . . .	147
40	"    " . . . . .	147
41	Cylinder Cooler . . . . .	149
42	Beilby's " side section . . . . .	151
43	"    " end " . . . . .	151
44	McCuthon's Cooler, side section . . . . .	154
45	Hydraulic Press . . . . .	156
46	Filter " . . . . .	157
47	"    " construction of Plates . . . . .	158
48	Section of Filter Press Plates . . . . .	158
49	Ammonia Sulphate Apparatus, general view . . . . .	172
50	"    " Still, Beilby's . . . . .	175
51	Plan of Cracker Box . . . . .	177
52	Sectional side view of Cracker Box . . . . .	177
53	Oil Injector . . . . .	187
54	" . . . . .	188
55	Soda Recovery Cylinder . . . . .	207
56	"    " . . . . .	207
57	"    Tower . . . . .	208
58	End section of Oil Trap . . . . .	211
59	Side "    " . . . . .	211
60	Plan of "    " . . . . .	211
61	Side section of "    " wrongly designed . . . . .	211
62	Cold Test Apparatus . . . . .	216
63	"    " . . . . .	217
64	Boiling-point . . . . .	236
65	Laboratory Still . . . . .	238
66	"    Cold Press . . . . .	240
67	Apparatus for Preparation of Normal Paraffins . . . . .	258

## TABLES.

NO.	PAGE
I. List of Oil Companies, with dates. &c. . . . .	20
II. Shale distilled per annum . . . . .	29
III. Loans and Debentures compared with original Capitals . . . . .	31
IV. Depreciation in Share values . . . . .	32
V. Yield of Crude Oil from various Shales . . . . .	43
VI. Chemical composition of Shale . . . . .	45
VII. " " spent Shale . . . . .	45
VIII. Yield of Crude Oil for Horizontal and Vertical Retorts . . . . .	62
IX. " finished products from ditto . . . . .	63
X. Hourly yield of Crude Oil and Ammonia from Henderson Retorts . . . . .	77
XI. Henderson's <i>v.</i> Vertical Retorts, yields of Crude Oil, &c. . . . .	79
XII. " " " " finished products . . . . .	80
XIII. " Beilby's " " Crude Oil, &c. . . . .	83
XIV. " " " " finished products . . . . .	84
XV. " { Young & } " " Crude Oil, &c. . . . . { Beilby's }	90
XVI. " " " " finished products . . . . .	90
XVII. " " " " Scale and Lubri- cating Oil . . . . .	91
XVIII. Yield of Naphtha by compression <i>v.</i> absorption . . . . .	107
XIX. Specific Gravities of Crude Oils from various Retorts . . . . .	123
XX. Life, &c., of Stills . . . . .	192
XXI. Effect of Steam in Stills on yield of Coke . . . . .	192
XXII. Quantity of Steam used in Stills . . . . .	193
XXIII. Capacities of Stills, Fuel, Steam and Labour items . . . . .	194
XXIV. Showing fallacy of cracking Oil Column . . . . .	197
XXV. Boiling Points, Latent and Specific Heats and Vapour . . . . .	200

NO.		PAGE
XXVI.	Loss caused by Air Agitation . . . . .	203
XXVII.	Acid left in treated Oils . . . . .	204
XXVIII.	Relation between Cold Test and Percentage of Wax .	218
XXIX.	"                    "                    Viscosity . . . . .	221
XXX.	Viscosities at Various Temperatures . . . . .	222
XXXI.	Melting Points of Mixtures of Wax and Stearine . .	225
XXXII.	"                    "                    "                    " . . . . .	225
XXXIII.	"                    "                    "                    " . . . . .	226
XXXIV.	"                    "                    "                    " . . . . .	226
XXXV.	"                    "                    "                    " . . . . .	227
XXXVI.	"                    "                    "                    " . . . . .	227
XXXVII.	Illuminating Power of Burning Oil Distillates . . .	230
XXXVIII.	Strength of Sulphate of Ammonia Liquor . . . . .	235
XXXIX.	Treatment v. Distillation . . . . .	248
XL.	Specific Gravities of Waxes . . . . .	251
XLI.	Boiling Points, &c., of Normal Paraffins . . . . .	259
XLII.	Chemical Formulæ of " . . . . .	260
XLIII.	Comparison of Specific Gravity, Beaumé and Twaddell	261

# MINERAL OILS

AND

## THEIR BY-PRODUCTS.

---

### CHAPTER I.

#### HISTORICAL.

THE important part that the paraffin oil trade plays in Scotch manufacturing industries makes it deserving of a short history of its origin and subsequent development being recorded.

The late Mr. James Young, of Kelly, was the first to manufacture paraffin oil on a commercial scale; it might not therefore be out of place to deviate slightly here, and, in taking a passing glimpse at his early life, to note the immediate cause of his starting this important industry.

Born in the year 1811, in humble circumstances, Mr. Young at an early age was apprenticed to his father—who was a carpenter and cabinet maker by trade, in the city of Glasgow. While at this employment he attended Professor Graham's evening lectures on chemistry, and in a short time became so proficient in that science that he was appointed demonstrator to the Professor. He held this appointment ten years, and after that went as manager



to Muspratt's Chemical Works at Newton, near Liverpool, where he remained for four and a half years.

About the year 1843 he accepted an appointment at Tennant's Works at Manchester, and while there Dr. Lyon Playfair acquainted him of the fact that petroleum was oozing out of cracks in the sandstone roof of the Riddings Colliery, at Alfreton, Derbyshire, which belonged to his (Playfair's) brother-in-law. After a careful examination, Young advised his employer to work the petroleum with a view to converting it into a profitable business ; but his employer thought it would be too small a business for him to interest himself in, so Young took a lease of the oil-bearing portion of the mine himself, and, with Meldrum (whom he had met at Professor Graham's classes) as partner, started work in the year 1848 manufacturing paraffin oils. At that time only two kinds of oil were made by Young and Meldrum—one a thin oil for burning in lamps, and the other a heavy one for lubricating purposes. Meldrum had charge of the oil work, and Young continued his duties in the employment of Tennant.

The supply of the crude petroleum was at any time liable to become exhausted—as it did in 1851 ; and Young, being fully alive to this fact, and being of opinion that the oil was a product from coal that had been subjected to subterranean heat, he experimented off and on for over two years on the "artificial" production of petroleum. English coal that came to Tennant's yard for consumption in the furnaces was the first to be experimented with, with varying results, but at last a liquid which contained solid paraffin was

obtained from cannel coal. About this time (1850) Bartholomew, of the City and Suburban Gas Works, Glasgow, showed Young a piece of Boghead coal or "Torbanehill Mineral"; as it proved to be very rich in oil, Messrs. Young and Meldrum immediately experimented with all the different varieties of Scotch coals they could obtain, and they found a number of the Fifeshire coals gave results that compared very favourably with those obtained from the Boghead coal.

On the occasion of a meeting of the British Association in Edinburgh in 1850, Messrs. Young and Meldrum spoke to Mr. Benney on the subject of manufacturing paraffin oils from Scotch coals, and the outcome of the conversation was that the three gentlemen decided to erect a work at Bathgate, Linlithgowshire, for the manufacture of oil from Boghead coal. They had serious thoughts as to whether it would not be better to start on the Fifeshire side, but as Boghead coal was the cheaper they decided on Bathgate, and commenced building the works in 1850 and manufacturing oil in 1851. The contract of co-partnery between Young, Meldrum and Benney was signed in October 1851.

Having thus shortly traced out the origin of the Scotch mineral oil industry as regards "Boghead coal," it is now interesting to see what incident led to the manufacture of oil from "shale." According to an article entitled 'Struck Ile, or the Scotch Petrolia,' which appeared in the *Glasgow Weekly Herald* of November 18, 1865, a poor miner of the historic name of Douglas, who had charge of boring operations for some coal-masters, one day instructed the borers in his

charge to keep samples of all the different minerals through which the boring instruments passed. Among the samples were some pieces of "Scaly Blaes" which arrested his attention and set him thinking. Taking a clean clay tobacco pipe, and filling the bowl with the broken blaes, he cemented the top with soft clay and then placed the bowl in the fire. In a short time gas poured out in miniature volumes from the pipe stem, and then a black fluid began to drop from the orifice. After repeating this experiment over and over again, he suspected this "black fluid" contained paraffin, but had no means of testing it; and, rather than take into his confidence somebody who would have been able to help him, and make his discovery of pecuniary value to him, this canny Scot preferred to keep his knowledge to himself, and consequently the results of his experiments did not come to light until too late to be of any value to him.

Robert Bell, Esq., of Clifton Hall, Linlithgowshire, kindly furnished the author with the following statement: "In the year 1859 I took a lease of the Broxburn minerals, and shortly afterwards, while searching for coal, came across large quantities of shale. When I saw the manner in which this shale burned, I determined to experiment on it, and had experimental retorts erected at Wishard, where large numbers of samples of the shale were distilled. The results were so encouraging that I immediately made arrangements for working the Broxburn minerals on a large scale, and thus started the manufacture of mineral oils from shale in the year 1862."

As we have already seen, 1850 was the red-letter

year of the Scotch mineral oil industry, as at the latter end of that year Messrs. Young, Meldrum and Benney commenced building the famous Bathgate Oil Works, which were completed early in the year 1851.

In the contract of co-partnery Young agreed to supply the process for manufacturing the oil (which process he had protected by patent rights before setting up the retorts), Meldrum undertook to take charge of the works and personally superintend the manufacturing details, while, in Scotch phraseology, Benney "put up the rocks"—not the shale rocks, but that medium of commerce more generally known as pounds, shillings and pence.

The retorts that were first erected at Bathgate were of the ordinary horizontal gas-retort type, which gave an oil of such poor quality that Young felt very dissatisfied, and after the lapse of about two years he instituted the use of vertical retorts. The quality of the oil and expeditiousness with which the coal could be handled, resulting from this change in the form of retort, was so satisfactory that—according to James Taylor, one of Young's first employés—when Young entered the works one morning, about a fortnight after the new retorts had been in operation, and had made his usual simple tests of the crude oil, he suddenly rushed over to where Meldrum stood, and, after nearly capsizing that gentleman in his enthusiasm, caught hold of his hand, and, whilst vigorously shaking it, gasped out, "Meldrum! I congratulate you, for our fortunes are made."

The first contract made by Young and Co., for Bog-

head coal was in October 1850, at the rate of 13s. 6d. per ton, but at the latter end of August 1860 the price had risen to 26s. per ton. One ton of this coal yielded about 22 lbs. of solid paraffin (0·098 per cent.), which substance was considered troublesome, and as much as possible was sent away in the different grades of oils, while that which separated from the oils of its own accord was removed and burnt.

In 1854, Young commenced to separate the solid paraffin—by artificially cooling the oil—and stored it up in large quantities in the works, but it was not until 1858 that a practical process was discovered for refining it. It was greatly due to the inexhaustible energies of John Galletly, Young's chief chemical adviser, that paraffin wax became a commercial article in 1859.

Great curiosity was, of course, manifested by all inhabitants in the neighbourhood, and for miles around the Bathgate Oil Works. To prevent too inquisitive people from learning or seeing too much of the methods and machinery used in making and refining the crude oil, a massive stone wall, calculated to withstand an attack of artillery, was built round the works; and the two heavy wooden gates, which afforded the only means of ingress and egress, being constantly guarded, caused the works to be generally spoken of as "the secret oil works." Young was fully aware that even the above precautions were not wholly adequate to prevent men, who might gain admittance in the guise of workmen, from learning his secrets; and therefore, to make his secrets doubly secure, he adopted names for the various products, which, to the uninitiated, gave no clue what-

ever as to the stage in refining to which any of the products belonged. For instance, he called crude oil Black Liquor; crude oil after distillation, Green Liquor; lubricating oils after the extraction of the wax, and before the acid and soda treatment, Blue Oil; and refined lubricating oil, when ready for the market, was termed Finished Liquor.

In 1851 two oil works were in existence in Scotland, one being the Bathgate and the other a small work at Crofthead; which latter was of small account, and only did business for barely a year, thus leaving only the Bathgate work in existence in 1852.

In 1853 the Clydesdale Chemical Company, often erroneously called the Cambuslang Oil Company, started in the oil business, and its operations led to one of the most famous lawsuits ever tried by jury. The trial commenced on November 1, 1860, and lasted over a week, during which time the services of Great Britain's most eminent chemists were brought into requisition by either one side or the other, their testimony being taken with a view to determining the line of demarcation between shale and coal. The Clydesdale Chemical Company's works were built at Cambuslang by Brown Brothers and Co., with Bain (on whose estate the works were situated) as sleeping partner. When operations were first commenced, crude oil was produced from Parrot coal, but the company eventually resorted to the use of Boghead coal, which they retorted by the process known as the Continuous Distillation in Ovens, obtaining by this process a yield of 85 to 90 gallons, of 880 specific gravity, crude oil per ton of coal. Refining

operations were also carried out at these works, and everything went along prosperously for about seven years. As the company was using an infringement of Young's patent, it very naturally made every endeavour to prevent the nature of the work it was engaged in being made public; but notwithstanding every precaution being taken, word reached Young's ears of what was going on in those works, and he immediately started the law plea above referred to; and, being awarded a favourable verdict by the jury, he stepped in and relieved the Clydesdale Co. of 6000*l.* and 3*d.* or 3½*d.* on every gallon of crude oil manufactured by it. The result was disastrous to the company, which was completely ruined, and Brown Brothers withdrew from the business in 1862; but Bain took Carlile (who had previously been acting as chemist for the company) into partnership, and the new firm carried on the business under the name of Thomas Carlile and Co. until the year 1867, when the work was finally abandoned.

In 1857 three oil works were in existence, when Miller and Sons had started their work at Aberdeen, where crude oil was produced from Boghead coal. This work did a flourishing business in both crude and refined oils until the year 1864, in which year the work was closed, owing partly to the high price of Boghead coal, but perhaps more particularly to the fact that Young discovered that Miller and Sons were infringing his patents.

In 1860 Sir James Simpson started a work at Oakbank, Mid Calder, Midlothian, and, after receiving fairly good returns from his investment for three years, he formed a private company which was very success-

ful, and led to the oil work and mineral fields finally becoming the property of a limited liability company which was floated in the year 1869.

Dougal and Brothers' oil work was also started in this year, near Blackburn House, Blackburn, Linlithgowshire. The work might have been in operation to this day had the supply of shale held out, but, as it was, the supply of that commodity only fed the thirty retorts for two to three months, and, after spending 8000*l.* in a fruitless search for more shale, their retorts to the query "How's the oil business?" were cold indeed.

Simpson started a work at Benhar in this year, and it was in operation until about 1874, when it became the property of a limited liability company floated by Simpson; but before the company had a chance to get started they found the capital had all been absorbed.

In 1861 five new works sprang into existence, some of which only lived for a year, and some for eight to nine years. The longest-lived was the Harthill Oil Work, owned by Paul and Grey, who had a ready buyer for their crude oil in the Inverkeithing Oil Works Company, when the latter started refining in 1864.

In 1862 seven more works were started, of which the West Calder Oil Company's (also known as Fell's) Work, situated about half a mile from West Calder village, was the most important. This work was originally intended for the crude oil business only, but after a few years of prosperity, the company launched out into the refining business also. This move was the principal cause of the downfall of the company, because the market value of finished products



fell to such an extent, just when the refinery was ready to start, that the anticipated returns from the money invested in the erection of the refining plant were never realised. The company failed in 1879, and its work was bought by Young's Paraffin Light and Mineral Oil Company, Limited, who pulled down all the apparatus that was of any worth and transferred it to their Bathgate and Addiewell Works.

In this year Bell sublet a portion of his shale fields to Fauld, under the condition that a stipulated quantity of shale be retorted per annum, and failing that the work was to be abandoned. Fauld built a work just north of Broxburn village, and set up thirty-six horizontal and thirty-two vertical retorts, but in a year or two found his inability to comply with the terms of the lease and had to confiscate his work to Bell, who about 1865 let it to Steel, together with a lease of the shale fields, under the same conditions as Fauld had it. Steel found his level with Fauld after a very few months' practical work, and therefore the Broxburn Oil Work (under which name the work had gone) again reverted to Bell, who then carried on the crude oil business himself, until he eventually disposed of the work and shale fields to what turned out to be one of the most successful of the Scotch oil companies, namely, the Broxburn Oil Company, Limited.

The year 1863 brought forth eight more works, but only one of those needs special note, and it was the Addiewell Works. The fast approaching exhaustion of the Boghead coal mines about the year 1859-60, caused Young to look around elsewhere for a new supply of oil-

yielding material. As burning oil was at that time in greater demand and more profitable than the lubricating oils, or even wax, and as the Addiewell shales were known to yield a larger percentage of burning oils than any of the other shales, Young took a lease of those shale fields and concluded to build a new work in their vicinity. The corner stone of the oil refinery was laid by Young's intimate friend, Dr. Livingstone (the noted African explorer), and the works were completed about the latter end of 1865. This work will be referred to more particularly under the year 1866.

In the year 1864 no fewer than thirty-eight new works sprang into existence. One of these, started by Messrs. R. Carrick and Arnott, was known by the name of the "Methyl Paraffin Oil Works," and was situated at the north-east corner of Methyl "old" harbour, in Fifeshire. The crude oil was made from a gas coal found in the Pirnie Parrot Coal Seam, which later on was found to the north-west at a depth of only twelve feet from the surface. The crude oil was refined and sold in the neighbourhood for 3*s.* 6*d.* per gallon; but a year or so later a contract was made to supply a Newcastle merchant with the oil at the rate of 2*s.* 6*d.* per gallon. The tanks in which the oil was stored while in course of purification were made of brick and cement; but this method of storage led to such a large loss by leakage that the firm failed in 1868, and the members had to leave the country in order to escape arrest. Mr. Benney (on whose estate the work was situated) carried on the business until 1870, when he gave it up as unprofitable.

John Nimmo and Sons started a work at Thirlstone, near Grange Pans, at the east end of Boness. It contained forty-two retorts in all, twenty-seven of which were round in cross section, and made at Inverkeithy, while fifteen were of the flat type, made by Ballantine at the Grange Foundry. The original intention of the proprietors of this work was to manufacture oil from waste Parrot coal, but finding it unprofitable, they used Boghead Parrot and finally Methyl coal. The latter was shipped to them in sloops from the north side of the Forth, and yielded about 40 gallons of 880 specific gravity crude oil per ton. Although a refinery was erected it was never put into use, and was eventually pulled down and sent to Slammanon. The work was closed in the year 1867.

In 1865 the number of new works that appeared on the scenes was eleven. Of these, the one built by the North British Oil and Candle Company, and situated at Lanark, where the crude oil brought from Shott's Oil Work was refined, has perhaps received more public notice than was either anticipated or wished for. This company is noted as being the first of the Scotch companies to manufacture candles; but it did not make a success of even that, and, after struggling along for a number of years, it was finally reconstructed in the year 1883.

1866 is noted as being the year in which the much-heard-of Young's Paraffin Light and Mineral Oil Company, Limited, came into existence. It was started with a capital stock of 600,000*l.*, of which about 400,000*l.* was paid to Young for his Bathgate and Addiewell Works, together with the leases of the shale

fields, &c., while Young retained a large holding in the company, and acted on the board of directors.

Although this company was fairly prosperous for some years, and had an output equal to about one-third of the total production of the Scotch works combined, it cannot be said to have been a financial success of late years; due, firstly, to its having been handicapped, as a large dividend payer, by the burden of carrying such an excessively large capital, and secondly, being the first company of any importance, the works were necessarily fitted up with expensive apparatus and machinery that proved in a few years to be unsuitable for refining the oils so as to suit the more exacting requirements of the later-day trade, and consequently extensive and expensive alterations in the plant were constantly being made. While this company was spending thousands of pounds on experiments and new apparatus, outsiders were carefully watching the results, and when new companies were formed they reaped the benefit of Young's company's experiences and built their works on more systematic plans, and adopted the use of only such apparatus as experience had proved was efficient, thus escaping the necessity and heavy expense of making radical changes.

Had Young's company adopted the policy of patenting its improved apparatus, &c., instead of relying on its employés to keep such matters secret, it would be in a decidedly better financial position to-day than it is, and some of the younger companies would be paying royalties to it instead of using its improved processes and apparatus *ad lib.* Thirdly, Young's

company met with a serious loss in the withdrawal of Mr. Young from the board of directors, as he was the only man on the board who had had any really practical experience in the manufacture.

Sixteen other works, besides Addiewell, were started in this year, and of these only four will be specially noticed. One, the Uphall Oil Work, started by Messrs. Meldrum, McLagan and Simpson, had a successful run for some years. Meldrum supplied the necessary funds, McLagan the shale, as the work was on his estate, and Simpson took the management. This work became the property of the Uphall Oil Company, Limited, in 1871, and of Young's company in 1884.

Another work was the Coatbridge Oil Work, which was locally known as the Waterford Oil Work, on account of most of its officials and workmen being Irishmen. The work was situated at Kirkwood, near Coatbridge, and consisted of 109 Griffiths' patent retorts, and a refinery that was capable of handling the crude oil produced by the other works in the district as well as its own—the total amount of crude oil it refined averaging 2,746,000 gallons per year. The gas coals of the district, bonnets and shales of different kinds, were retorted, and yielded about 40 gallons of crude oil per ton of mineral. This work was sold in the year 1878, but, owing to the purchasers failing to obtain a lease of the minerals, it was closed after that date.

Another notable company was the Glasgow Scottish Oil Company, which was a private concern that erected a work at Burngrange, West Calder, and went out of

existence the same year—after making 10,000 gallons of crude oil at a cost of 10,000*l*.

Lastly, the Hermand Oil Work, started by Dennit and Brown near West Calder, was noteworthy on account of the seam of shale worked by this concern—and named after Dennit—afterwards turning out to be one of the most valuable seams in the West Calder and Addiewell districts. The work was abandoned in 1873.

In 1867 one new work, the Sterlaw Oil Work, was started. It was situated at Sterlaw, near Bathgate, and was built by Meldrum, McLagan and Simpson, for the production of crude oil, which latter was sent to the Uphall Work to be refined.

The year 1868 was fruitless, while

In 1869 only one new work and one company put in an appearance. The company was registered under the name of the Oakbank Oil Company, Limited, and had a capital of 60,000*l*. It took over the Oakbank Oil Work, built by Simpson in 1860, and which was the property of the Mid Calder Oil Company in 1863. The Oakbank Company was very successful at the start, but the constantly decreasing prices for finished products, together with the adoption of a bad form of retort, brought it to the verge of bankruptcy in 1886, and necessitated its reorganisation. The extension to the works and general reorganisation were completed in May 1887, after an expenditure of 30,236*l*., and the company was then placed once more on an equal footing with its competitors.

In 1870 two new works were started, but were of no special note, and

In 1871 two more new works started operations and one old work changed hands.

Of the new works, that of the Dalmeny Oil Company, Limited, will be specially referred to. This company has been a phenomenal success, and as it has always been a crude oil work only, and has not had any special advantages as regards shale fields, &c., it points to the fact that there is not much profit in refining unless done on a sufficiently large scale; and if some of the other ventures had followed the Dalmeny Company's example, and stuck to the crude oil business, and left the refining to those more capable of doing it, it would have been better for all concerned.

The new company formed this year was the Uphall Oil Company, Limited, capitalised at 170,000*l.*, which bought the Uphall and Sterlaw Oil Works, built by Meldrum, McLagan and Simpson, 1866-67. The company eventually met with insurmountable reverses, and being unable to do any better, finally amalgamated with Young's company.

In 1872 two small new works were started, one near Paisley and the other at Benhar.

In 1874 a limited liability company was formed to take over Simpson's "Benhar" work, but the capital was all absorbed, and Simpson suddenly found a change of climate necessary for his health.

In 1877 the famous Broxburn Oil Company, Limited, was floated, with a capital of 180,000*l.* This company bought up the oil work and shale fields acquired by Bell in 1862. Bell, besides being a large stock-holder, also took an active interest in the management of the

company, which latter has been one of the greatest successes in the history of the Scotch oil industry.

The Straiton Oil Company also started in this year, with a capital of 50,000*l.* It was anything but a booming success, and will be again noticed in 1882.

In 1880 the Walkinshaw Oil Company, Limited, with a capital of 120,000*l.*, bought up the Abercorn Oil Work (which had been built near Inkerman in 1871), and also a work built by Jas. Greenshields and Co. near Johnstone in 1866. This company, like many others, was more heard of in the Liquidation Court than elsewhere.

The Clippens Oil Company, Limited, with a capital of 360,000*l.*, bought up the Clippens Oil Work (started by Benney in 1871), together with the Pentland Oil Works.

In 1881 the Burntisland Oil Company, Limited, was floated, with a capital of 20,000*l.*, and took over the Binnend Oil Work.

In 1882 the Straiton Oil Company, Limited, got into such straitened circumstances that it had to be either financially reconstructed, or give up business. As there still appeared to be plenty of people with more money than brains, ready to rush blindly into the oil business, sufficient capital was soon raised to buy out the Straiton Oil Company, and carry on its business under the name of the Midlothian Oil Company, Limited—see 1884.

In 1883 the oil craze seemed to take a fresh spurt, no less than six new companies appearing on the field:—

The Bathgate Oil Company, Limited, capitalised at 50,000*l.*, and works at Seafield.



The Pumpherston Oil Company, Limited, with a capital of 70,000*l.*, and works at Pumpherston.

The Westfield Oil Company, Limited, with a capital of 25,000*l.*, bought the old Capeldrae Oil Work.

The Westlothian Oil Company, Limited, with a capital of 100,000*l.*, erected a crude oil works at Deans, and bought Simpson's old Benhar work and used it as a refinery.

The Philipstoun Oil Work, started by the private company "Jas. Ross & Company," two miles east of Linlithgow, with, it is said, a capital investment of 60,000*l.*

Last—but not least as far as trouble goes—the Lanark Oil Company, Limited, which spent 80,000*l.* on improvements at the old Lanark work of the late North British Oil and Candle Company. The company also acquired Fernie's tumbled-down Cobbinshaw Oil Work, at which latter work they produced the crude oil and distilled it, sending the distilled oil to the Lanark work to be refined. After running two years, the directors found it advisable to reduce the original capital of 10,000 shares of 10*l.* each to 10,000 shares of 6*l.* each!

In 1884 oil companies were harder to float, but notwithstanding that fact three new companies were formed and two changes of ownership took place.

The new companies were:—

The Linlithgow Oil Company, Limited, with a capital of 200,000*l.*, and works at Champfleurie, Linlithgow.

The Holmes Oil Company, Limited, capitalised at 100,000*l.*, and having a work at Holmes, Uphall.

The Millburn Oil Work, owned by the private company of Smith Brothers and Murling.

The changes in ownership were, the amalgamations of the Uphall company with Young's company, and the Midlothian company with Clippens' company.

In 1886 the Hermand Oil Company, with a capital of 265,750*l.*, built a crude oil work at West Calder, and did a fair business until it took the Walkinshaw Oil Company into amalgamation in 1890. The principal reason for the amalgamation was to secure the Walkinshaw company's refinery, which had been standing idle since 1886. It of course entailed the expenditure of a very large sum of money to put the refinery into working order, not to speak of the new and improved machinery that was bought "to enable the company to manufacture or refine oil as cheaply as its competitors;" and, when everything was ready to start, the company concluded that, as market values had taken a sudden drop, they would close up both their works until the market improved again. Both works are still closed!

The year 1887 was a black one for the Scotch oil trade generally, as will be seen later, but notwithstanding that, it was only too apparent the backbone of the trade was broken.

In 1889 the Caledonian Mineral Oil Company, Limited, was floated, with a capital of 120,000*l.*, and acquired the mineral fields of Tarbrax, Greenfields and Cobbinshaw, together with the crude oil work at Cobbinshaw and refinery at Lanark, formerly the property of the Lanark Oil Company (then in liquidation). The purchase price was 45,000*l.* This company paid one 5 per cent. dividend, but since then has kept quiet on the subject of dividends.

TABLE I.

H. Rs. = Horizontal Retorts.

V. Rs. = Vertical Retorts.

Name of Work or Company.	Original Proprietors.	Location.
Abercorn Oil Work . . .	Abercorn Oil Co. . .	Near Winchburgh, I man
Aberdeen " . . .	Miller & Sons . . .	Near Aberdeen . . .
Addiewell " . . .	Jas. Young . . .	Addiewell, West C Midlothian
Airdrie Mineral Oil Co. . .	" . . .	Airdrie . . .
Albyn Oil Work . . .	Fernie . . .	Broxburn . . .
Arden " . . .	Trustees of John Wil- son of Dundyan	Near Caldercruix, near drie
Armadales " . . .	P. Scott. . . .	Near Armadales . . .
Auchenheath Oil Work . . .	J. & J. Baird . . .	Lesmahagow . . .
Avonhead " . . .	Douglas & Boag . . .	" . . .
Bankhall " . . .	" . . .	" . . .
Bathgate " . . .	Young, Meldrum & Benney	Bathgate . . .
Bathgate Oil Co. . . .	" . . .	Seafield . . .
Bathville Oil Work . . .	Wm., John & Thomas Watson	Bathville . . .
Bellsquarry " . . .	" . . .	Bellsquarry, nr. W. C
Benhar " . . .	Simpson . . . .	" . . .
" " . . .	Thornton . . . .	" . . .
" " . . .	? . . . .	" . . .
Binnend " . . .	? . . . .	Fifeshire . . .
Birkenshaw " . . .	Allen Craig & Sons . . .	1½ miles from Larkha
Blackburn " . . .	Dougal Bros. . . .	Blackburn, near Blac House
Blackston " . . .	Blackston Mineral Co. . .	Blackston, near Paisle
Blackstoun " . . .	Allen Craig & Co. . .	Linwood, near Joh Paisley
Bridesholme " . . .	" . . .	Uddingston . . .
Broxburn " . . .	Fauld . . . .	" . . .
" " . . .	Liddle . . . .	West end of Broxburn
" " . . .	McClintock . . . .	Roman Camp " "
" " . . .	Pointer. . . .	S. side of canal, Brox
" " . . .	Steele . . . .	N. " "
Broxburn Oil Co., Ltd. . . .	" . . .	Broxburn . . .

*HISTORICAL.*

**TABLE I.**

**D. Rs. = D-shaped Retorts.**

**S. G. = Still Going.**

Abandoned or Changed Hands.	Remarks.
1880	H. Rs. to end of 1871, and then 240 V. Rs. ; crude oil only ; 1880, Walkinshaw Oil Co.
1864	H. Rs. ; crude and refining.
S. G.	Afterwards Young's Paraffin Light and Mineral Oil Co., l
1874	
1866	Fauld's Work rebuilt ; V. and H. Rs. ; reverted to Bell.
1870	12 Bell and 12 Cowan Rs. ; stood a year or two, then rented J. Kirk for short time.
1867	24 H. Rs. ; crude only ; gravity 895 to 902.
1868	
1871	
1870	
1887	First Scotch Oil Work ; Young's P. L. & M. O. Co. in 1866 ; and 1887, sulphuric acid manufactory only.
1892	Bankrupt 1887, and handed over to sequestration under control
1873	[J. Pender.]
1871	
1874	Bought by West Lothian Oil Co. 1874, and worked until 1883.
1875	
1876	
1881	Bought by Burntisland Oil Co. ; now in hands of Receiver.
1871	20 D. Rs. ; crude oil only.
1860	30 H. Rs. ; " "
1879	
1886	44 V. Rs. ; crude oil only.
1873	
1862	Afterwards Albyn Oil Work.
1867	30 H. Rs.
1868	12 H. Rs. ; about 1865 Fraser's property, and then 75 H. Rs. and
1867	30 H. Rs. ; crude oil. [small refinery.]
1868	30 H. Rs. and 50 V. Rs. ; crude only.
S. G.	

Name of Work or Company.	Original Proprietors.	Location.
Buckside Oil Work . . .	McLagan . . .	Near Pumpherston
Burntisland Oil Co., Ltd. . .	.. ..	Burntisland, Fifes
Caledonia Oil Work . . .	Geo. Simpson . . .	Paisley
Caledonian Mineral Oil Co. . .	.. ..	Cobbinshaw and I
Capeldrae Oil Work . . .	.. ..	Cardenden, Lochg
Capputhall Bog Oil Work . .	Ferris, Fernie & Co. . .	Near Cobbinshaw
Carlowrie Oil Work . . .	.. ..	.. Kirkliston
Clippens Oil Co., Ltd. . .	.. ..	Paisley
Clippens Oil Work . . .	Robt. Binney & Son . .	Near Johnston, Pa
Clydesdale Oil Co. . .	Brown Bros. & Co. . .	Cambuslang
Cobbinshaw Oil Work . . .	Brand & Hislop . . .	Cobbinshaw
.. ..	Fernie . . .	Tarbrax, South Co
.. ..	John & Alex. Mungle . .	Half way on no Cobbinshaw Lo
Coneypark Oil Work . . .	.. ..	..
Craigie .. ..	.. ..	Kilmarnock
Crofthead .. ..	.. ..	Crofthead . . .
Crown Point .. ..	Palmer & Co. . . .	..
Dalmeny Oil Co., Ltd. . . .	.. ..	Dalmeny . . .
Drumcross Oil Work . . .	Lester & Wyllie . . .	..
Dryflat .. ..	J. Robertson, Jun. & Co.	..
Drumgray .. ..	J. Rankin . . . .	Greengairs
East Fulton .. ..	Jas. Greenshields & Son	Near Johnston . .
Fergushill .. ..	.. ..	Dreghorn, Kilmar
Forth and Clyde Oil Work . .	.. ..	..
Glasgow Scottish Oil Co. . .	Bryden, managing part- ner	Burngrange, West
Glenture Oil Work . . .	Robinson, Donald & Co.	..
Grange .. ..	J. P. Raeburn . . . .	Gungreen Toll, V
Greendykes .. ..	Robt. Bell . . . .	..
Greengairs .. ..	Thornton . . . .	Greengairs
Harthill .. ..	Paul & Gray . . . .	Hartwood Estate,
Hermant Oil Co. . . .	.. ..	Breich, West Cald
Hermant Oil Work . . .	Thornton . . . .	..
.. ..	Dennit & Brown . . . .	$\frac{3}{4}$ mile east of We south side of ra
High Possil .. ..	Walker . . . .	..
Holmes Oil Co., Ltd. . . .	.. ..	Holmes, Uphall
Hurlford Oil Work . . .	.. ..	Kilmarnock

Abandoned or Changed Hands.	Remarks.
1867	Formerly Binnend Oil Work.
1895	
1871	
..	Successors to Lanark Oil Co.
1868	Afterwards Westfield Oil Co.
1878	
1877	
S. G.	Formerly Binney's Clippens Oil Work. ; 1881, refinery only.
1873	After 1873, Binney only ; 272 Rs. ; crude and refinery.
1862	After 1862, Thos. Carlisle ; continuous distillation in ovens ;
1871	[crude and refinery.
1873	41 H. Rs. ; sold to Black in 1873 ; Lanark Oil Co.'s in 1883.
1873	36 D. Rs. ; crude only.
1870	
1876	
1851	
1867	
S. G.	
1870	Bought by Oakbank Oil Co., and pulled down.
1871	
1874	
1873	20 H. Rs., crude and refinery to 1873 ; then Jas. Liddle & Co. ;
1878	[Walkinshaw Oil Co. in 1880.
1867	
1867	Crude only.
1877	
1876	
1871	100 Rs.
1867	
1869	
..	Shut down—waiting for better times !
1870	
1873	150 H. Rs. ; crude only.
1871	
S. G.	
1876	

Name of Work or Company.	Original Proprietors.	Location.
Hutchinson's Oil Work	Hutchinson . . . .	.. ..
Inverkeithen "	Andrew Munro, manager	.. ..
Kilrenny "	.. ..	Fife . . . .
Kilwinning "	.. ..	Ayre . . . .
Kirkwood "	Coatbridge Oil Co. .	Kirkwood, near Coatbr
Lanark Oil Co., Ltd.	.. ..	Tarbrax and Lanark .
Lanemark Oil Work .	.. ..	New Cummock . . . .
Leavenseat "	Gray & Thornton. .	Crofthead . . . .
Limerigg "	.. ..	Slammanon . . . .
Linlithgow Oil Co. .	.. ..	Champfleurie, Linlithg
Lochgelly Oil Work .	.. ..	.. ..
Low Possil "	Peter Drummond . .	.. ..
Methyl Paraffin Oil Co.	R. Carrick & Arnot .	N.E. corner of Methyl Harbour
Mid Calder Oil Co. . .	.. ..	Oakbank, Mid Calder.
Midlothian "	.. ..	.. ..
Milburn Oil Work . .	Smith Bros. & Murling.	Larkhall . . . .
Nettlehole "	.. ..	Airdrie . . . .
North British Oil and Candle Co.	.. ..	Lanark . . . .
Oakbank Oil Co., Ltd.	.. ..	Oakbank, Mid Calder.
Oakbank Oil Work . .	Sir James Simpson .	" "
Old Monkland Oil Work	.. ..	.. ..
Over Possil "	Drummond & Bain .	.. ..
Page & Co.'s "	Page & Co. . . . .	.. ..
Paraffin "	.. ..	Mandell . . . .
Pathhead "	.. ..	Fife . . . .
Pentland "	Clippens Oil Co. . .	Loanhead, near Edinbu
Philipstoun "	Jas. Ross & Co. . . .	Philipstoun, nr. Linlith
Port Dundas "	.. ..	.. ..
Pumpherstoun Oil Co., Ltd.	.. ..	Pumpherstoun, near Up
Riggend Chemical and Oil Work	.. ..	.. ..
Roachsoles Oil Co. . .	Law & Son . . . .	Raebog . . . .
Rosewell Oil Work . .	.. ..	Whitehall, Peebles Ros
Ross "	.. ..	Fauldkirk . . . .
Rougheraig "	.. ..	.. ..
Rowatt and Yooll Oil Work	Jas. Spence & Co. .	Anstruther. . . .

med.

d.	Abandoned or Changed Hands.	Remarks.
4	1866	
1	1869	Refinery only ; supplied with crude from Harthill Oil Work ; had twelve 1500-gallon stills made of malleable iron, and double
4	1869	[riveted concave bottom.
4	1871	[refined 2,500,000 gallons per year.
6	1878	109 Griffiths Patent Rs. ; crude and refinery ; also bought crude ;
3	1886	160 Young and Beilby Rs. at Tarbrax ; refined at Lanark ; after-
4	1867	[wards property of Caledonian Mineral Oil Co.
4	1870	
4	1872	
4	..	
4	1869	
4	1872-3	
4	1868	40 H. and V. Rs. crude and refinery ; sold to Binney, 1868, then 16 Rs. and crude only ; stopped 1870.
3	1869	After 1869 property of Oakbank Oil Co., Ltd. [1884.
2	1884	Formerly the Straiton Oil Co. ; amalgamated with Clippens Co.,
4	..	Crude only ; made chiefly from dross of main seam of common coal.
5	1875	
5	1883	Refinery only ; made candles 1866 ; property of Lanark Oil Co. 1883.
9	S. G.	Formerly Mid Calder Oil Co. ; been reconstructed number of times.
0	1863	Property of Mid Calder Oil Co., 1863, and of Oakbank Oil Co.,
6	1870	[1869.
4	1869	
4	1871	
4	1873	
7	1876	
0	S. G.	See Clippens Oil Co., Ltd.
3		
6		
3	S. G.	
5	1874-5	
4	1872	
4	1871	
4	1865	
4	1871	
5	1870	



Name of Work or Company.	Original Proprietors.	Location.
Sevinhill Oil Work . . .	.. ..	Dalserf, Lanark.
Shand's " . . .	Geo. Shand & Co. . .	Stirling . . .
Shettleston Oil and Chemical Co. . . .	.. ..	East Glasgow . . .
Shotts Oil Work . . .	Geo. Gray & Alex. Dick	Dykehead, Hillhouse Shotts . . .
Stanrigg " . . .	Black . . . . .	New Monkland, Airdrie
Sterlaw " . . .	Meldrum, McLagan & Simpson	Sterlaw, near Bathgate
Sterlaw Oil Co. . . .	.. ..	.. ..
Stewartfield Oil Work . . .	.. ..	.. ..
" " . . .	Robt. Bell . . . . .	.. ..
Stewart's " . . .	Stewart . . . . .	Stewart Estate, W. Cal
Straiton " . . .	Straiton Oil Co. . . .	Loanhead, near Edinbu
St. Rollox " . . .	Cairns & Co. . . . .	.. ..
Struther's " . . .	Struther . . . . .	.. ..
Taylor's " . . .	Taylor & Co. . . . .	Leith . . . . .
Thirlstane " . . .	Jno. Nimmo & Sons . .	Boness, east end of Gr Pans . . . . .
Uddingston Oil Co. . . .	Newall & Co. . . . .	Kirkwood . . . . .
Uphall Oil Co., Ltd. . . .	.. ..	Uphall . . . . .
Uphall Oil Work . . . .	Meldrum, McLagan & Simpson	" . . . . .
Vulcan " . . . . .	.. ..	Port Dundas . . . . .
Walkinshaw Oil Co. . . .	.. ..	Inkerman and Johnsto
West Calder " . . . .	Fell . . . . .	West Calder . . . . .
Westfield Oil Co., Ltd. . .	.. ..	Fife . . . . .
Westlothian " " . . . .	.. ..	Deans and Benhar . . .
Whiterigg Oil Work . . .	Jas. Pattison . . . . .	New Monkland . . . . .
Young's Paraffin Light and Mineral Oil Co., Ltd.	.. ..	Addiewell, Bathgate Uphall . . . . .

*HISTORICAL.*

L.

Abandoned or Changed Hands.	Remarks.
1870 1871 S. G.	
1871 S. G.	30 H. Rs. ; crude only ; supplied crude to North B Candle Co. and Uphall Oil Co.
1875	Became property of Uphall Oil Co. in 1871.
1872 1866 1871 1865 1882 1865 1869 1871 1867	60 H. Rs. 100 H. Rs. After 1882 property of Clippens Oil Co. Distilled Straiton shale. 27 Round, 15 Flat Rs. ; crude only ; refinery built, but not r
1870 1886 1871	Locally known as Nackerty [with Young's Co. in 186 Formerly Uphall Oil Work and Sterlaw Oil Work ; amalgamat Became property of Uphall Oil Co. in 1871.
1866 1890 1879 .. .. 1870 S. G.	[and East Fulton Oil Works Amalgamated with Hermand Oil Co. in 1890 ; formerly Abercor. Bought by Young's Co. in 1869, and then puiled down. Formerly Capeldrae. Bought Simpson's Benhar Work for a refinery. Formerly Young, Meldrum and Benney, and also Uphall Oil Co. Ltd.

The tabular statement (Table I.) shows the dates, as nearly as could be ascertained, of the starting and closing of the various works, together with other information of interest that could be obtained.

It is certain that within the forty-five years' life of this industry 117 works have been built, and this number may possibly have been greater, as there is a liability that one or two unimportant and small works may have existed for a short time and have escaped the Author's investigations. Some of the 117 works changed hands three and four times, and altogether there were twenty-four changes of ownership that are known of, and therefore, practically speaking, 141 different proprietors have tried their hands at the business.

In 1850—52	oil works	were in operation.
„ 1860—67	„	„
„ 1870—61	„	„
„ 1880—19	„	„
„ 1890—14	„	„
„ 1895—12	„	„

It will be seen by referring to Table II. that the shale distilled in late years shows a great increase over former years. The companies engaged in the crude oil business only have earned and paid very fair dividends, whereas those engaged in the crude and refining business have been sorely tried.

As the price of crude has fallen proportionately with the fall in price of finished products, it is very evident that far greater strides have been made towards

TABLE II.

Year.	Tons of Shale Distilled.		
	East Scotland.	West Scotland.	Total.
1873	439,615	84,480	524,095
1874	277,210	84,700	361,910
1875	377,108	46,314	423,422
1876	454,892	86,381	541,273
1877	581,351	102,767	684,118
1878	535,626	110,313	645,939
1879	624,912	87,516	712,428
1880	730,777	63,060	793,837
1881	840,259	71,912	912,171
1882	898,754	93,733	994,437
1883	1,043,499	87,230	1,130,729
1884	1,365,157	104,492	1,469,649
1885	1,665,667	76,083	1,741,750
1886	1,655,427	43,717	1,699,144
1887	..	..	1,368,704
1888	..	..	2,026,779
1889	..	..	1,962,715
1890	..	..	2,154,824
1891 to 1895	Averaged	each year about	2,000,000

cheapening the cost of retorting shale than in refining the crude oil. The refining is still carried on with the use of the small apparatus used years ago, or with but very little increase in size, so that but slight reduction in the cost of labour, steam, repairs, &c., has been effected, and

the refiners have been unable to do a profitable business in competition with the "go-ahead" foreign manufacturers; and from a once prosperous and thriving industry the Scotch oil trade has now dropped to a virtually unremunerative one, with but few good prospects ahead.

The year 1886-87 was undoubtedly the worst the Scotch trade ever experienced, and all the companies were more or less sufferers.

Young's company headed the list with a year's working loss of 42,325*l.* 16*s.* 8*d.*, without allowing anything for depreciation.

The Linlithgow Oil Company came next with a loss of 3904*l.*, and then the Pumpherston company with a loss of 1160*l.*, making a total loss in one year of 47,389*l.* 16*s.* 8*d.*

Broxburn, instead of declaring its usual 25 per cent. dividend, only had 15 per cent. to declare; Burntisland gave its shareholders only 7 per cent., as against 20 per cent. of the year before; and Holmes company's shareholders had to be satisfied with 5 per cent., as against the previous year's 8 per cent.

In these days, holders of the regular shares in the Scotch oil companies stand a poor chance of sharing in the profits (if there are any) of the companies, owing to the latter having burdened themselves with enormous sums in debentures, loans and preference shares, on which interest must be paid, and by the time that is paid but little, if anything, is left for the shareholder.

Tabular statement No. III. shows the amounts of loans and debentures compared with the original capitals of

TABLE III.

Name of Company.	Original Capital.		Loans and Debentures.	
	1886.	1887.	1886.	1887.
	£	£	£	£
Broxburn . . . .	199,750	199,750	64,608	85,106
Burntisland . . .	119,450	144,950	51,500	55,200
Clippens . . . .	247,650	247,650	103,184	122,051
Holmes . . . . .	35,000	35,000		
Linlithgow . . . .	159,374	160,000	..	43,816
Pumpherstons . . .	76,500	107,270	52,345	48,040
West Lothian . . .	82,314	74,898*	10,466	7,400
Young's . . . . .	605,625	605,625	435,548	526,262

\* After reduction in capital.

the various companies in 1886 and 1887. It will be seen that the Holmes is the only company that has kept itself free from this burden, while the other companies have involved themselves to an extent of from  $\frac{1}{10}$  to  $\frac{5}{8}$  their original capital, making a total increase of liabilities of 190,705*l.* over the year 1886.

Since 1884 the depreciation in the value of the shares has been ruinous to investors, as will be seen by referring to Table IV.

The above depreciation in share values means a total loss to investors of 1,124,044*l.*, in two years.

From 1887 to 1891 the companies had a hard struggle for existence, and notwithstanding that the beginning of 1891 showed no brighter prospects for the oil trade than the previous years, yet a new concern

consultations between the American and Scotch oil representatives was the formation of the Scottish Mineral Oil Association in 1887. At the start this Association did not comprise the whole of the Scotch manufacturers, owing to the perverseness of certain directors of the companies; but after a while these men gradually commenced to come to their senses, and the companies they represented joined in with the others, with a view to regulating and maintaining prices. Things then moved along smoothly for a while, until one of the companies found it had more products ready for the market than the Association saw its way to relieve the company of, and so, rather than curtail its manufacture until the demands of the market increased, it withdrew from the Association and placed its products on the market at a greatly reduced figure, thus lowering market values and upsetting what benefit to the companies the Association had been able to achieve in a short time. By dint of hard work and much persuasion, the Association finally won the recreant company back to its fold, but had hardly done so before another withdrew and upset calculations again.

It is therefore not surprising that after a chequered career of about five years the Scottish Mineral Oil Association finally disbanded in November 1892, and the companies went back to their old tricks of trying to undersell and otherwise ruin each other; while at the same time they were busy looking around for feasible excuses to give their shareholders for not being able to pay a dividend, or having to decrease its amount.

Another very serious cause of the almost bankrupt

condition of some of the companies, is the fact that the heads that govern them are men entirely devoid of practical experience. It is undoubtedly very important that every company should have a good financier, but because it is fortunate enough to possess one is no excuse for giving him full sway in matters not pertaining to the financial part of the business. Most of the managing directors in the Scotch oil trade have had no practical experience whatever; and not only that, but although they almost invariably have thoroughly practical men under them, they are often too dignified to consult and take the advice of those who are subservient to them, and rather prefer to give arbitrary orders that sometimes do, but more often do not, give the desired results. Sometimes the works managers are so far ignored that the directors will bring in a stranger to value their works plant and report on it. Of course the reason for such action is obvious, as a stranger cannot possibly obtain an accurate knowledge of the actual condition of the plant by a few superficial examinations that he may make, and consequently he enables the directors to tell the shareholders that they (the directors) are proud to be able to say that a "perfectly disinterested engineer" who has examined the plant, reports that it is in perfect condition and values it at so much. Had the works manager, who knows exactly what the condition of the plant is, been called upon, as he should be, to make a report on the condition and value of the plant, he would give a very different tale, and his report, therefore, would be unsuitable—for what it was wanted! If the shareholders, instead of quietly



believing all that their company's directors tell them, would take the matter into their own hands, and appoint a committee to see that there were properly qualified men in the proper places, and more particularly that the said qualified men are allowed to make use of their experience, discretion and knowledge for the benefit of the company, without being interfered with by a man or men who know nothing about the practical manufacture, they would be taking a most important step in the direction of placing the industry on a paying basis once more; and until they so act but little improvement can be looked for.

Another cause of great loss of money is the adoption by the board of directors—who, as before stated, are generally men of no practical experience—of patented “theoretical” apparatus or processes. The word theoretical is used on account of the fact that sometimes the practical working of the plant has never been properly determined, and its adoption is liable to result in a loss of many “bawbees” to the company, while the patentee gets the benefit of the experience of the practical experiment with his apparatus, &c., at no cost to him. Before these experiments are tried, the company's practical men are either entirely ignored, or sometimes their opinion is asked for, and if they give an adverse criticism they are considered prejudiced, and the experiment goes merrily on.

One or two of the companies that have been amongst the biggest dividend-payers, besides being in the best financial condition in these critical times, have a number of practical men on the board of directors,

do not waste money on outsiders' theoretical patents, but rather encourage their own employés to improve the processes and apparatus; and above all, consult the practical men of the different departments and act on their advice.

It is only too apparent that unless a unanimous and harmonious combination of the companies soon takes place, together with radical changes in the management wherever needed, we shall in a few years be left to mourn the loss of one of Scotland's most important industries.

## CHAPTER II.

## GEOGRAPHICAL AND GEOLOGICAL.

A LARGE number of the oil works were outside the shale limits, and the crude oils that they manufactured were products of Parrot and cannel coals, coaly shale or bastard Parrot, and also colliery dross. Those works that make the true shale oils are confined in a comparatively small area of the country extending from Straiton and Burntisland in the south-east and north-east, to Cobbinshaw and Linlithgow in the south-west and north-west, or a distance of about twenty-five miles east and west by twelve miles north and south.

Of course there are shales found in other sections of the country, but the section between the points just named is the only one that has been really of any great commercial value.

The Author is greatly indebted to his old friend the late Mr. Alex. Lumsden, mining engineer to Young's company, for being able to give an accurate diagram showing the geological positions of the various seams of shale. It will be seen from this diagram (No. 1) that the shales of Midlothian are found in the calciferous sandstone series lying between the Mountain and Burdiehouse Limestones. The thickness of the section is very variable, and ranges from 300 fathoms

## SECTION.

## DIAGRAM I.

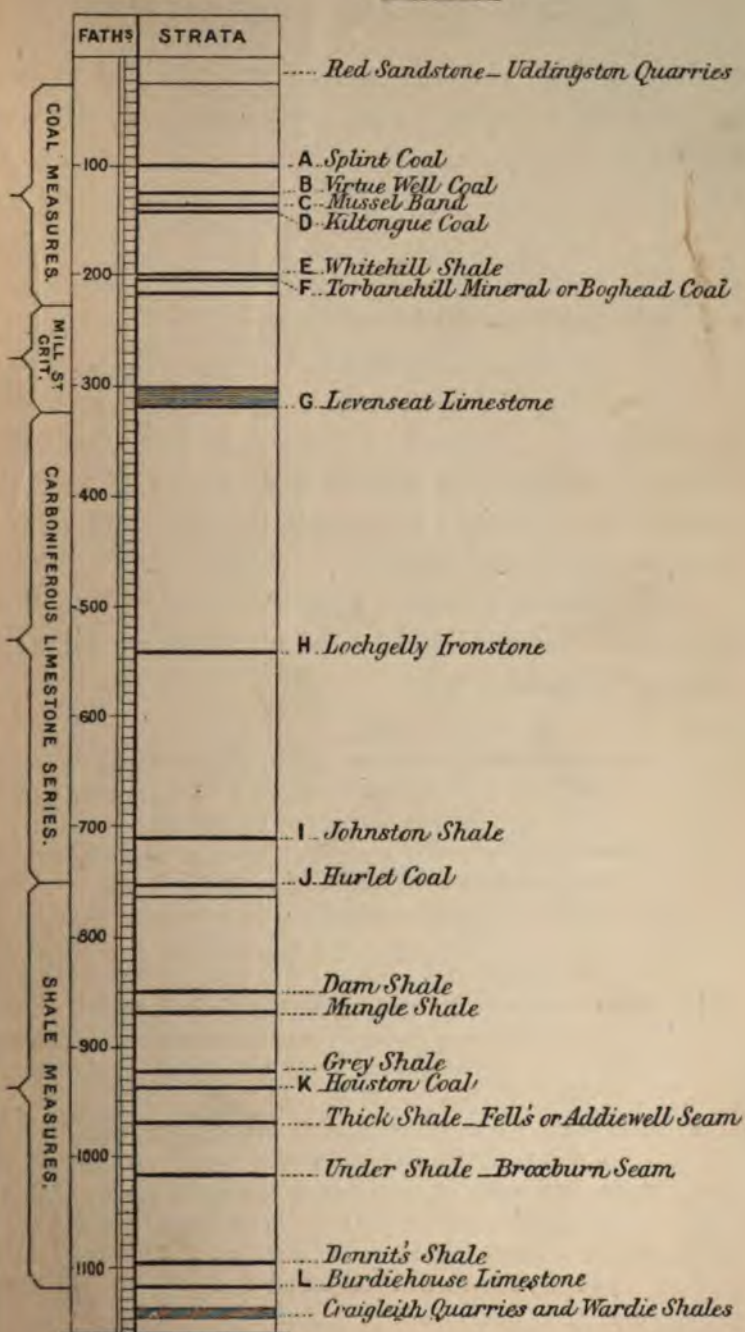

at Addiewell to 150 fathoms at Straiton. The section contains many different seams, but the principal commercial ones are—

Fell's,  
Broxburn,  
Dennit's,

and their respective thicknesses are—

3 feet.  
5 „  
9 „

The rest of the shale section is made up of several thin and unimportant shale seams, together with sandstones and indurated clays.

The following reference matter adds greatly to the value and interest of Mr. Lumsden's diagram, and was prepared by him :—

Ref. Letter.

- A. Associated with this seam is a third-rate Parrot coal, 9 inches thick, which yields on distillation 32 gallons of crude oil per ton, and was wrought at Provanhall, Coatbridge.
- B. Immediately over this seam is a seam of shale 8 inches thick, wrought at Arden, Airdrie.
- C. In this position is a seam of true shale, 8 inches thick, and yielding 50 gallons crude oil per ton. Extensively wrought around Airdrie.
- D. The top part of this seam consists of a kind of gas coal, which yields 32 gallons crude oil per ton. Wrought near Airdrie.
- E. This is the seam that is found at Westfield, Fifeshire. Yields 40 gallons crude oil per ton.
- F. This seam is now exhausted. It was the first mineral used in the production of paraffin oil.
- G. Above this seam of limestone is a seam of shale yielding 29 gallons crude oil per ton. Wrought at Leavenseat.
- H. Associated with this ironstone is a seam of a kind of shale yielding 32 gallons crude oil per ton.

Ref. Letter.

- I. All the Renfrewshire oil works are supplied from this seam. Gives 45 gallons crude oil per ton.
- J. It is between this seam and the Burdiehouse limestone that the best and most profitable shale seams are found.
- K. Associated with this seam is an earthy kind of gas coal. Wrought at Drumcross, near Bathgate.
- L. Over this limestone a shale is sometimes found. It was wrought in a quarry between Livingston and Bathgate. No shale has yet been found under the Burdiehouse limestone.

### SHALE.

Bituminous shale, from which Scotch oils are derived, might at first sight be mistaken for coal, but on close examination distinct differences will be noted.

In the first place, shale lacks the intense blackness of coal, varying in colour from a grey to dark clove brown, and, unlike coal, it does not dirty the fingers when handled.

Secondly, a lump of bituminous coal may be easily broken into small pieces by striking it with a hammer, but a piece of shale would require ten times the exertion before it could be similarly broken; and the pieces of shale thus broken would display a conchoidal fracture, whereas the fracture of the coal would be laminated.

From a structural point of view shale may be divided into three classes, viz. :—

Plain shale.

Curly „

Leafy „

The first mentioned, as its name implies, has a plain appearance, such as an ordinary piece of broken rock. The curly shale has a wavy or curly structure, and gives one the impression that it has been subjected to an enormous lateral pressure during the early stages of mineralisation. Leafy shale, which might also, perhaps, be termed scaly shale, consists of semi-loose scales which can easily be separated with the blade of a knife. It is usually of light brown colour, and is found almost solely at "outcrops," and therefore this structural peculiarity is doubtless due to the action of the weather on what was previously, perhaps, plain shale. Leafy shale is of little or no value as an oil-yielding medium, and is of no commercial value, but is often sought after by collectors of natural curiosities, as it usually contains fine specimens of fossil ferns, &c., which are more easily separated and prepared for exhibition than those found in the other shales.

A curious feature in regard to shales is the very widely diverging character of the same seam in different districts. To such an extent does the same seam vary in character, that seams that are very profitable to work in one district are entirely unprofitable in another, although the two districts may be only one or two miles apart; and this diminution in the value of a seam is always in a westerly direction.

Table V. gives the yields of crude oil from different kinds of shales and coals from various sources. Some of the shales that show the smaller yields of crude oil are often far more valuable to the companies than the shales that give twice or thrice the quantity of crude

oil. This is due to the fact that the crude oil resulting from shales or coals that give a large yield, generally contains very little paraffin wax and large amounts of burning and lubricating oils, and the latter of low specific gravity and poor lubricating quality. It is, therefore, necessary to make a careful examination of the crude oil before any definite opinion can be formed of the value of a shale.

TABLE V.

Name of Mineral.	Gallons of Crude Oil per Ton of Mineral.
Addiewell Thick Shale . . . . .	27·38
Asiatic           " . . . . .	22·40
Auchenlea       " . . . . .	50·00
Auchenheath   " . . . . .	39 to 78
Boghall         " . . . . .	26·22
Boghead Coal   . . . . .	85 to 128
Burnside "St. Andrew" Shale . . . . .	26·97
Cairney Hill     " . . . . .	10·88
Capeldrae (first quality)   " . . . . .	70 to 81
" (second quality)   " . . . . .	41 to 65
Canadian       " . . . . .	54·00
Cobbinshaw (Ferne's)   " . . . . .	44·80
" (Mungle's)   " . . . . .	33·77
Cockmydron     " . . . . .	31·58
Dalmeny        " . . . . .	34·60
Denbrae        " . . . . .	10·90
Denhead        " . . . . .	14·25
Doura or Patterson   " . . . . .	36·45
Fortneuk       " . . . . .	29·81
Gorebridge     " . . . . .	74·66
Grey            " . . . . .	24·39



TABLE V.—*continued.*

Name of Mineral.	Gallons of Crude Oil per Ton of Mineral.
Inkerman Shale . . . . .	45·63
Kirkcaldy „ . . . . .	32·49
Knightswood „ . . . . .	36·00
Ladedda „ . . . . .	74·95
Lesmahagow „ . . . . .	39·00
Limefield (West Calder) Shale . . . . .	28·30
Lochgelly „ . . . . .	28·70
Methyl Brown Coal . . . . .	65 to 90
Methyl Black „ . . . . .	49 to 52
Mid Calder Oil Company's Shale . . . . .	28·70
Midhill „ . . . . .	50·00
Muttonhole „ . . . . .	43·00
Newliston „ . . . . .	23 to 32
Overton „ . . . . .	64·00
Omoa Gas „ . . . . .	47·70
Rochsoles Coal . . . . .	72·00
Seafeld Shale . . . . .	36·40
Turva Mineral . . . . .	69·00
Uphall Shale . . . . .	29 to 34
Wellwood Coal . . . . .	46·00
Wemyss „ . . . . .	60 to 70
Westfield Shale . . . . .	18·50
Westwood „ . . . . .	29·30

The specific gravity of shales does not vary very greatly, and usually ranges between 1·713 and 1·877. The specific gravity of the Boghead coal or Torbanehill mineral was 1·224.

The average composition of a good shale is given in

Table VI., while Table VII. gives the analyses of spent shales taken from the old form of Vertical and the Henderson retorts.

TABLE VI.

Constituent.	Per Cent. by Weight.
Moisture (at 240° F.) . . . . .	2·67
Volatile matter . . . . .	24·31
“ Fixed ” carbon . . . . .	12·50
Ash . . . . .	60·50
Total . . . . .	99·98

TABLE VII.

Constituent.	Per Cent. by Weight.	
	From old Vertical.	From Henderson.
Carbon . . . . .	18·40	3·61
Silica . . . . .	49·14	56·49
Oxide of iron . . . . .	10·45	12·81
Alumina . . . . .	18·37	22·72
Lime . . . . .	1·68	1·77
Magnesia . . . . .	0·99	0·95
Sulphur . . . . .	1·05	1·15
Total . . . . .	100·08	99·50

## CHAPTER III.

## THEORETICAL.

SHALE, in the form in which it is mined, does not contain any oil or oily matter, and no oil can be obtained from it until it has been subjected to a sufficiently high heat to bring about its decomposition or the breaking up of its chemical constituents, so as to allow the latter to rearrange themselves and produce oil, &c. That oil does not exist in shale as such can be easily proved by reducing the shale to a fine powder, and then mixing it with any solvent of oil, such as benzol, naphtha, ether, &c., when it will be found that these solvents fail to extract any oily matter whatever. Therefore a shale has to be subjected to heat, or to what is known as a destructive distillation, in order to obtain oil from it.

The oil which shale yields is chemically known as a hydrocarbon, because its constituent parts are hydrogen and carbon. There are two series of these hydrocarbons, one the paraffin and the other the olefine series.

When a hydrocarbon is heated, the oil first begins to boil and then to vaporise or distil, and if the vapours are further heated by passing them through a highly heated (bright red hot) tube, they will be decomposed into a permanent gas. We therefore see that the shale should be distilled at as low a heat as possible in order

to obtain as much oil and as little gas as possible. It would be comparatively easy to distil shale so as to produce but a small quantity of gas, if the oil were present in the shale as oil; but it not being so necessitates the shale being heated to a considerably higher temperature than that necessary to merely distil the oil, in order to overcome the chemical affinities that hold the hydrocarbons in the peculiar state in which they are present in the shale, and in order to accomplish the commercial necessity of rapid working. When these chemical affinities have been overcome, and the hydrocarbons freed, the latter are subjected to a high heat before they are able to escape, and are consequently partly decomposed into permanent gas; but the amount of decomposition that takes place varies greatly with the form of retort used and the method of working the retorts.

It is evident that to accomplish the distillation of shale, and obtain the best results, the heating surface of the retort should be as large as possible in comparison with the area of the internal cross section, so that the retort need not be excessively heated in order to distil the shale that is farthest away from the heating surface; and that the oil vapours should be removed from the retort as soon as possible, and be protected as much as possible (while in the retort) from the excess of heat. The oil resulting from vapours that have not been sufficiently quickly withdrawn from the retort, or sufficiently protected from the heat, is very liable to have what is technically called a "burnt" smell.

Since ammonia water became such a valuable by-product of shale distillation, another needed condition in the distillation presented itself, and that was that scientific experiments demonstrated that the whole of the nitrogen in the shale is not eliminated until the spent\* shale has been freed of all its carbon, and in order to burn out all the carbon the shale has to be subjected to a nearly white heat.

We therefore see that in theory the shale should be distilled at a low heat in order to obtain the maximum yield of oil with production of as little gas as possible, and that it should also be subjected to a very high heat in order to obtain the maximum yield of ammonia; while at the same time precautions must be taken to prevent the oil from becoming "burnt." Also, the retort should be constructed so that it can be charged, and the spent shale withdrawn, as easily, expeditiously, and with the aid of as little labour as possible. Under the heading "Retorts" we shall see how, by gradual steps, these conditions have finally all been combined in one retort, which retort is about as near theoretical and practical perfection as it is possible to get.

Having obtained the crude oil, it is then necessary to refine and separate it into its various products. The crude oil, as it comes from the retorts, is of a dark greenish-black colour, and when cold, of about the consistency of soft butter. Its principal constituents are paraffin and olefines contaminated with oily bases

\* After all the volatile matter has been volatilised.

and phenols, and more or less spent shale dust, &c. The dust and other suspended solid matter is easily separated by allowing the oil to settle in the storage tanks, but the oily bases and phenols have to be removed by the use of acid and alkalies.

When the oil is shaken up with acid, the latter combines with the oily bases, and also with the lower members of the olefines, forming a heavy black tarry mass, known as "acid tar," that settles to the bottom on allowing the mixture to stand at rest for some hours. It has been found in practice that it is not possible to remove the whole of the bases by one or even two acid treatments, and that a number of treatments are necessary.

The lighter oils are more susceptible to the action of the acid than the heavier ones, and too much or too strong an acid is liable to "burn" them and make their subsequent refining difficult, besides wasting acid; therefore, as is explained under the heading "Treating," considerable judgment has to be used in regard to determining the strength and quantity of acid to use in the various stages of refining.

It is, of course, hardly necessary to state that all kinds of acid have been tried for the treatment of oils, and the results of numberless experiments have proved sulphuric acid to be the only one practically suitable for the work.

In the alkaline treatment of the oil, caustic soda is principally used, but in certain stages it is often found advantageous to use carbonate of soda. The alkali, besides neutralising any free acid that may

remain in the oil after it has received its acid treatment, attacks the phenols, and forms a thin tarry-looking mass which settles to the bottom of the oil.

It must be remembered that the oily bases which the acid extracts are not decomposed by the acid, but form a simple chemical combination, and should the acid tar be neutralised with soda or any other alkali, the bases will be at once set free and come to the surface in the form of an oil. Therefore it is of the utmost importance that an acid-treated oil be allowed to settle until as thoroughly freed from acid tar as is practicable, because any acid tar that it may contain when it receives its soda treatment will be neutralised, and the oily bases thus liberated will at once go back into solution in the oil.

The same caution also applies to the soda tars, but as the oil after the soda treatment does not usually receive another acid treatment until after a distillation, there is little or no danger of the phenols being set free and redissolved by the oil.

The oily bases are perhaps the most detrimental impurity to have in the oil, owing to their objectionable smell and the quickness with which they oxidise and turn red, and finally reddish black, thus preventing the manufacture of an oil that will keep its colour if any oily bases are present.

The phenols also oxidise and redden, but not as rapidly as the oily bases, and they have not such a disagreeable smell. Of course both impurities must be removed from an oil before we can have a properly and thoroughly refined oil.

There is another important operation that the oil has to undergo in the process of refining, and that is a distillation. The distillation performs three functions, namely—

First, it enables the oil to be separated into various grades or products, such as naphtha, burning oils, heavy oils containing wax, &c.

Secondly, it separates soluble impurities in the oil that cannot be removed by a judicious application of chemicals.

Thirdly, it brings about a crystalline condition of the higher members of the paraffin group that were previously in a gelatinous or amorphous condition.

The specific gravities at which the distillates are separated from the various products vary according to requirements, as will be explained under "Refining."

The impurities that are separated by the distillation are certain carbonaceous, earthy and sulphurous matters. The largest amount of the carbon or coke that remains in a still after the distillation is finished, is the result of the decomposition or "cracking" of the oil rather than the presence of actual impurities; and this fact can be easily demonstrated by taking a quantity of thoroughly well refined oil—water-white burning oil for instance—and distilling it in a glass flask over an Argand burner. A few per cents. will distil off at the start without much change being noticeable, but the oil is in reality all the time assuming a brown colour, which very gradually gets darker and darker until, after becoming noticeable, it has become a decidedly dark brown; and as the distillation approaches completion the colour is



almost or quite black; and when the distillation is finished a deposit of carbon will be found in the bottom of the flask, and perhaps more or less on the sides.

The cause of coke being formed in the still is due to the decomposition of the lower members of the paraffin into olefine hydrocarbons, and as olefines contain less carbon than paraffins, it is necessary that when this decomposition takes place there should be a rejection or deposition of carbon. It is therefore plain that every time a hydrocarbon is distilled it causes a decrease in the percentage of paraffins and increase in the percentage of olefines; and for this reason, and because paraffins are more valuable products than olefines, it is obvious that a hydrocarbon should not be distilled more times than is absolutely necessary.

The fact that a distillation brings about the crystalline condition of a paraffin—provided it contains solid paraffins—can be well demonstrated by taking a quantity of vaseline (which is really a wax in the amorphous condition) and distilling it very slowly. When the distillation is finished, it will be found that on cooling the distillate there are distinct signs of crystalline formation; and if this distillate is re-distilled two or three times, the crystals will finally be so well developed on cooling, that the distillate may be placed in a cloth and pressed, so that a cake of wax will remain in the cloth after the oil has been expressed. This result could not possibly be accomplished by pressing the original vaseline.

In this process of promoting the crystallisable quality of the paraffin, decomposition of course takes place, and

the higher members of the paraffin group are decomposed to the next lower members, or, in other words, the higher melting point waxes are reduced to lower melting point ones, and therefore every distillation lowers the melting point or chilling point of the oil distilled.

A wax obtained from the heavy or latter end of a distillation has very fine close crystals as compared with the wax obtained from a very much lighter or lower specific gravity oil, and therefore, as the heavier oil gives the higher melting point wax, the higher melting waxes always have the smallest crystals.

There is another condition that greatly affects the crystalline condition of a wax, and that is the method adopted in cooling it. If a melted wax, or mixture of wax and oil, is suddenly brought in contact with a cold surface, it will at once congeal and show scarcely any crystalline formation; whereas, if the same wax or mixture be allowed to cool very slowly, the crystals will be large and well defined. This is a most important point to remember, because in the stage of refining where the wax is extracted from the oil, great difficulty is often experienced in pressing and making a thorough separation, and this difficulty is often due to too quick cooling—but, of course, may be also partly or wholly due to the need of another distillation.

## CHAPTER IV.

## PRACTICAL.

IN order that the details of the manufacture may be more easily followed, it will be as well to first outline the course that has to be pursued in order to obtain the crude oil and by-products.

The shale as it is received at the mine head is loaded into side or bottom dumping railway wagons, and is then transferred to the retort department along the overhead railway track A (Fig. 1). The contents of the wagons are then dumped into the shale breaker B, and, after passing through the latter and into small trucks, are hauled up the incline C to the level of the top of the benches of retorts D, and, their contents having been discharged into the retorts, the process of destructive distillation commences. The vapours and gases pass out of the retort through the connections E and into the mains F and G, which latter conduct them to the air condenser H. In the air condenser the separation of the gaseous and liquid products takes place; the latter, which consist of a mixture of crude oil and ammonia water, are pumped to their respective storage tanks, while the former passes on through the connection I to the exhauster house J, and from there is forced through K into the coke tower M, where any

volatile oil that it may contain is extracted. The gas, thus robbed of its last traces of oil, continues along through L and back to the retorts, where it is burned as fuel in the furnaces. The volatile oil extracted in the coke tower is dealt with in the apparatus N.

Having thus shortly outlined the process of destructive distillation, we will now proceed to follow the process in all its details.

On account of the shale being in the form of large irregular masses, when it arrives at the works, it is necessary to reduce its size in order to charge it into the retorts. In the early days, when Boghead coal was used, a gang of men, supplied with long-handled hammers, used to be kept busy breaking up the coal to the requisite size, but when shale supplanted Boghead coal, it was found that even a quadruplication of the number of men did not enable the supply of broken shale for the retorts to equal the demand—so difficult was the shale to break—and therefore it was found necessary to devise some other and cheaper means of doing the work. This necessity led to the invention of a mechanical device, the construction and working of which will now be explained. It consists of a large wooden hopper B (Fig. 2), constructed of heavy timber, and lined on the inside with iron plates securely bolted to the wood. The upper portion of the hopper, and on the side on which the shale is received, is built at an angle, so as to prevent the shale falling directly on breakers *cc*, and causing undue strain to the machinery, but at the same time the angle is such that the shale cannot remain on it, and has to slide down. The

breakers are cast-iron discs, provided with coarse teeth on their periphery. These discs are about 3 feet in diameter and about 3 inches thick, while their teeth are about 3 inches long by  $1\frac{1}{2}$  inch wide, by 3 inches high, and the centre of the disc is cored square to fit a shaft with a square cross section of 6 inches. A sufficient number of these discs are placed on two shafts to form what are practically two toothed rollers, about 9 feet long, with their teeth running diagonally across them. They are placed parallel to each other

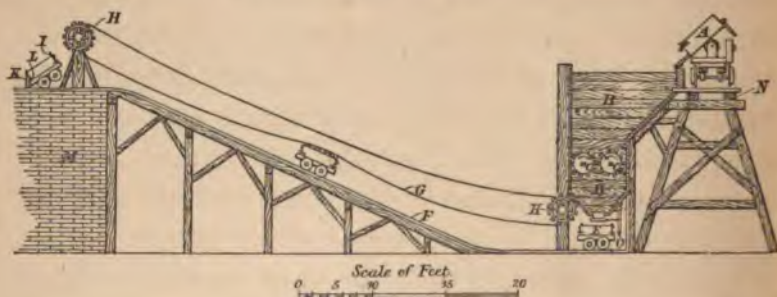

FIG. 2.

in the hopper, with a tooth clearance of about an inch, and are connected by means of heavy gears so as to revolve towards each other and thus draw down the shale and crush it as it passes between them to the lower hopper D. The lower hopper acts as a reservoir for broken shale, and is closed on the bottom by an iron slide actuated by the lever O.

As the side-dumping wagons A arrive along the elevated track N they are dumped into the hopper, and the small trucks or "hutches" E are then filled and pushed to the foot of the incline F, where the

endless chain G engages in the projection I on each end of the truck and hauls it up the incline. The axles of the wheels of these trucks are set as close together and as near the centre (lengthways) of the truck as possible, so that the attendants who charge the retorts can, with a slight effort, easily tip the truck and discharge its contents, after loosening the catch L that holds the swinging ends K in place. Each truck is constructed so as to hold just sufficient shale to charge one retort. When a truck is emptied it is run on to the down track of the incline, and its projections, I, engage in the endless chain that is travelling in the direction of the breaker, and it is by this means prevented from "running away." The whole of the machinery and gearing connected with this part of the work is not shown in Fig. 2, as it would be more or less confusing, and it is sufficient to say that the endless chain G is set in motion by sprocket-wheels or sheath-pulleys geared from the engine that runs the breakers.

#### RETORTS.

In the infancy of the trade only two forms of retorts were in vogue, namely, the horizontal and plain vertical. When the late James Young first started his oil work at Bathgate, he used ordinary D-shaped horizontal gas retorts, each of which was fitted with a screw running lengthways through the centre and worked from the back end by "tooth and pinion" wheels. The coal (Boghead) was fed into the retort from a hopper (placed above the front end of the

retort) and was carried along by means of the rotating screw and discharged into a water lute or trough of water at the back end. About two years after Young started, he erected three cylindrical cast-iron retorts vertically in a fire chamber that was common to the three ; their tops were surmounted by hoppers, while the bottoms were sealed by dipping into troughs of water. Either Mr. Young or Mr. Meldrum was in constant attendance during the first week of the working of those vertical retorts, and by the end of the week the retorts had proved so satisfactory that Young told Meldrum that their fortune was made. The horizontal retorts were then almost entirely superseded by the vertical retorts, which latter were cylindrical cast-iron pipes about 18 inches in diameter by 10 to 11 feet high.

Owing to the tendency of Boghead coal to swell and the broken pieces to stick together when heated, considerable trouble was experienced in manipulating these straight cylindrical retorts, as the spent coal would not readily pass downwards, and the lumps had to be separated and pushed down with iron bars. In order to overcome this difficulty, Young had some tapered cylindrical retorts cast, and set them in brickwork with their larger end downwards and sealed in water the same as the former ones. Each retort was fitted internally with a helical screw, the shaft of which projected upwards and was surmounted by a gear. A main shaft that ran the length of the retort benches supplied power to the screw gears and kept the screws moving at a very low rate of speed, which was just

sufficient to keep the contents of the retorts in constant motion—and that in a downward direction—and prevent them from sticking together. This method of construction and working proved highly successful, and was continued for about eight years, when, owing to the introduction of a radical change in the shape of the retort, the use of the screws was discontinued. The erection of a set of screws to work out the shale from the water troughs, and thus save labour, had been completed, but some experiments in that line showed that it did not greatly decrease the manual labour, while any saving in labour that was effected was more than offset by the cost of keeping the machinery in repair.

The change in the shape of the retort that led to discontinuing the use of the screws was instituted by A. C. Kirk, who constructed a retort with an elliptical cross section and very much larger at the bottom than the top. The motive for giving the retort an elliptical form was to give a larger surface for the fire to play on, and less depth of material in the retort for the heat to penetrate, which conditions were expected to improve the yield and quality of the crude oil and reduce the amount of fuel used in heating the retorts. The anticipated results were fully realised, and the elliptical shape has been retained in all retort construction since then.

The shapes and sizes of the horizontal retorts that were used by the small works that sprang into existence in large numbers in the early days of the trade were various. If of large dimensions, they were usually cast



in two portions, consisting of the bottom and sides in one portion, and the top or cover in another. Fig. 3 is a cross section of Bell's patent retort, which was about 12 feet long by 1 foot, and 3 feet high. Cowan's retort, represented in cross section in Fig. 4, was 9 feet long by 5 feet 6 inches wide, and 1 foot 6 inches high. The cross section of another form of horizontal retort that found great favour is shown in Fig. 5. This retort was built in



FIG. 3.



FIG. 4.

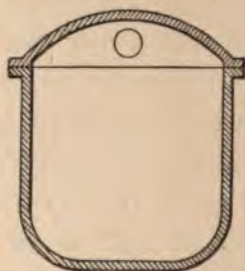

FIG. 5.

various sizes, but its average capacity was about 50 cwt. One furnace usually supplied heat for three horizontal retorts which were set over the fire, as shown in Fig. 6. The charges of shale or coal placed in the horizontal retorts usually weighed from 5 to 8 cwt., but, as above mentioned, some of the retorts had a capacity of 50 cwt. and over.

The value of the two forms of retorts (i.e. vertical

horizontal) as regards their respective yields of crude and cost of production of the same, together with the

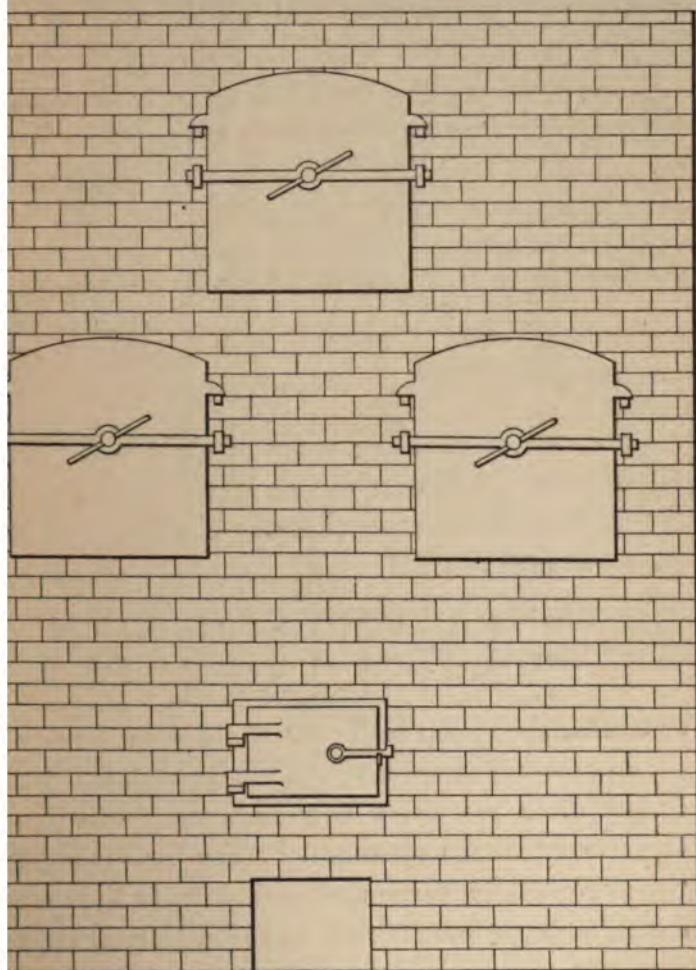

FIG. 6.

of refined products, will now be looked at, and the reason why the vertical eventually entirely superseded horizontal retort will then be easily seen.

Table VIII. shows the yields of crude oil from a ton of shale, and the figures are the average of a large number of determinations made on the working scale.

TABLE VIII.

Crude Oil per Ton of Shale.				Ratio of Yield of Crude Oil.	
Horizontal.		Vertical.			
Gallons.	Sp. Gr.	Gallons.	Sp. Gr.	Horizontal.	Vertical.
34·20	·870	39·79	·890	100	116·34

The cost of distilling a ton of shale in the horizontal and vertical retorts was respectively, 157·38*d.* and 157·56*d.*; and therefore the cost per gallon of the respective crude oils was :—

$$\text{Horizontal} . 157\cdot38 \div 34\cdot2 = 4\cdot60d.$$

$$\text{Vertical} . . 157\cdot56 \div 39\cdot79 = 3\cdot96d.$$

or 0·64*d.* per gallon in favour of the vertical retorts.

In proceeding to consider the marketable products derived from the above two crude oils it will be advisable to compare the horizontal "crude" with the vertical "once run oil," because the vertical crude had to receive a distillation before its acid and soda treatments, which the horizontal crude did not have to. The cost of this distillation was 0·5*d.* per gallon, and as the loss due to distillation was 8 per cent., the 39·79 gallons of vertical crude equalled 36·61 gallons of "once run oil," making a total cost of 4·46*d.* per gallon.

Table IX. shows the yields of finished products calculated on the above basis.

TABLE IX.

Horizontal.			Vertical.	
Product.	Yield.		Yield.	
	Gallons.	Per cent. by Volume on Crude.	Gallons.	Per cent. by Volume on Once Run Oil.
Naphtha . . .	0·855	2·50	0·863	0·99
Burning oil . .	15·903	46·50	14·831	40·51
Crude scale . .	1·953	5·71	3·108	8·49
Lubricating oil .	8·461	10·12	3·822	10·44
<b>Total .</b>	<b>22·172</b>	<b>64·83</b>	<b>22·124</b>	<b>60·43</b>

The above yields of products figured at the market values of those days realised the following amounts :—

	Horizontal.		Vertical.
	d.		d.
Naphtha . . .	10·046	. . .	4·265
Burning oil . .	272·498	. . .	254·129
Crude scale . .	63·277	. . .	110·699
Lubricating oil .	51·915	. . .	57·330
<b>Total .</b>	<b>397·736</b>	. . .	<b>426·423</b>

We obtained 34·2 gallons of horizontal "crude oil" from a ton of shale at a cost of 4·6*d.* per gallon = 157·38*d.*; and 36·61 gallons of vertical "once run oil" from a ton of shale at a cost of 4·46*d.* per gallon = 163·646*d.* If we deduct these costs from

the above values of finished products, we have:—  
 $397.736 - 157.38 = 240.356d.$  for horizontal products ;  
 $426.423 - 163.646 = 262.777d.$  for vertical products ;  
which shows an increase in value of products from a ton of shale of  $22.421d.$  in favour of the vertical retorts.

By referring back to Table IX. it will be seen that the horizontal retorts produce more naphtha and burning oils, but only five-eighths the amount of crude scale that the vertical retorts give ; and these figures, taken in connection with the fact that the horizontal crude oil does not need a distillation before it is treated, go to prove that the oil vapours are decomposed in the horizontal retorts, or are broken up into lighter and less valuable products than the vertical retorts yield.

Another important feature in favour of the vertical retorts was, that if the current of steam passing through the retort was regularly kept up, great uniformity of production was the result, and the quality of the oil was not greatly at the mercy of the fireman. On the other hand, if the horizontal retorts were not very carefully attended to, the yield of crude oil was liable to be greatly decreased, and its quality was always at the mercy of the fireman.

It being obvious that horizontal retorts are unsuited for the production of crude oil, we will not discuss them any further, but will turn our attention to the development of the vertical retort.

The vertical retorts in which the experiments to determine the respective merits of horizontal and vertical retorts were made were of the "Kirk" type, and their construction is shown in front sectional elevation

in Fig. 7, and in side elevation in Fig. 8. Referring to these two figures, A, the body of the retort, is provided with a hopper B; the hopper is composed of four separate castings which are, the funnel-shaped piece C, the short cylindrical piece D, and another funnel-shaped piece E, closed by the bell-valve F. To the flange at the bottom of the retort body is bolted a short casting G, that continues down under

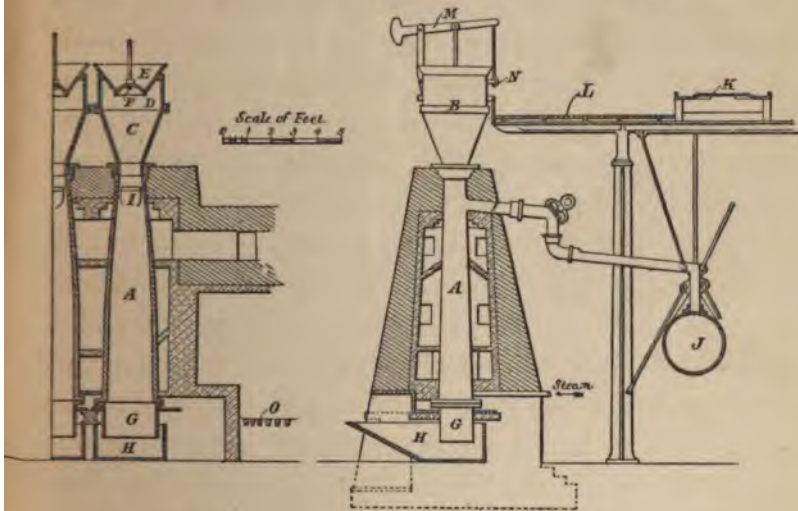

FIG. 7.

FIG. 8.

the surface of water contained in the trough H. The products of distillation passed out through the connection I and into the vapour main J. The shale to be charged into the retorts was brought in "hutches" along the elevated track K, and dumped on to the iron platform L. One furnace, O, supplied heat for six retorts—three on each side.

After the furnace fires had been started and the heat

of the retorts had reached an incipient red, the bell-valve F was lowered by the lever M (after the catch N had been loosened), and then the shale lying on the platform L was shovelled into the retorts; when the latter were filled the lever M was raised, the catch N replaced, and the joint between the bell-valve and upper hopper E was made gas and vapour tight by means of a little moist clay. When sixteen or seventeen hours had elapsed since the first charging of a new set of retorts, the shale was sufficiently "spent," or exhausted of volatile matter, to allow of the periodical charging and discharging to be commenced. Therefore, after, say, sixteen hours, a small portion of the spent shale was raked out from the water trough every half hour, and the quantity thus removed was regulated so that at the end of three hours it equalled the quantity of shale to be charged into the retort. The removal of the spent shale from the water trough allowed a corresponding quantity of shale to fall from the retort and fill its place, and at the end of every third hour there was sufficient room in the top of the retort to accommodate the 4 cwt. of fresh shale that constituted the charge. As the capacity of the retorts were from 20 to 22 cwt. it therefore took from fifteen to sixteen hours for the shale to travel from the top to the bottom of the retorts.

The heat from the furnace was first conducted around the lower third of the retorts, and then passed through pigeon-holed brickwork up around the middle third, and then through another set of pigeon-holes to the upper third, and from thence through a flue to the chimney. There was, therefore, a gradual increase in

the heat of the retort in a downward direction, and the shale entering the top had ample time to have its volatile matter distilled off before it was subjected to the higher heat of the lower portion of the retort, at which latter point a large amount of the ammonia was produced. As all the products of distillation were removed from the retort at a point near the top, and as nearly all the volatile matter was distilled from the shale before the latter reached the hottest part of the retort, it would appear that there was not much probability of undue decomposition of the oil vapours taking place. However, it was thought that the introduction of a small quantity of superheated steam at a point near the bottom of the retort might possibly aid the distillation and improve the quality of crude oil, and the results of experiments in this direction were (much to the surprise of the instigators) an increase of nearly fifty per cent. in the yield of crude oil. Ever since those experiments were made (in the year 1860) the distillation of shale has always been conducted with the aid of steam—if upright retorts were used. Steam in a horizontal retort resulted in no benefit, as it simply passed along over the *surface* of the shale.

The water trough H—which always had to be kept well filled with water—besides acting as a seal or lute to prevent the escape of oil vapours or gas, also quenched the hot spent shale as it fell into it, and when the shale was removed from the trough there was no danger of its setting fire to anything, and could therefore be loaded without further manipulation on to railway wagons and taken to the spent or waste shale bank.



These spent shale banks are monuments to the good old days gone by, and can be seen in all directions in the shale districts, and some of them reach quite extensive proportions, being nearly one-third mile long by three or four hundred yards wide and eighty to one hundred feet high.

The amount of coal necessary to heat the vertical retorts was 5 cwt. per ton of shale distilled. The average life of the retorts was about four and a half years, but even at the end of that time only the bottom third—where the fire had the most direct play—was seriously distorted and cracked, and the rest was usually in perfectly sound condition. To obviate the replacing of the whole of the retort, John Galletly suggested having it cast in two portions, so that that part which was most liable to be distorted by the heat could be easily replaced at a comparatively small cost. However, the suggestion was never put into practical use, and eventually this form of retort was superseded by others.

The first advances made towards improving the distillation of shale were :—

1. The adoption of a vertical retort.
2. The construction of a vertical retort with an elliptical cross section.
3. The introduction of steam amongst the distilling shale.

It is not intended to refer at present to the forms of retorts that have only been in use in limited numbers, and our attention will rather be confined, with one exception, to the consideration of the forms that may be said to have been of really commercial

importance. This exception is the McBeath retort, which was in operation at the Bellsquarry oil work about the year 1867, and is shown in section in Fig. 9.

A is the retort proper, hung up in the brickwork B by the lugs *a*. The upper casting *a*<sup>1</sup> was provided with an outlet pipe G and an opening F into which the hopper F<sup>1</sup> fitted. G<sup>1</sup> was supplied with a steam injector *g*, which, aided by the fan blower K, caused a constant current of vapours to pass along through G<sup>2</sup> to the main H leading to the condenser, and in that way helped to exhaust the retort of the oil vapours as soon as they were formed. The retort was operated by filling it with shale through the hopper F<sup>1</sup>, and then lighting coal fires on the portion of the grate-bars I near the furnace doors *d*. After the requisite heat had been attained, and the distillation had commenced, small portions of the spent shale were raked out from under the lower extremity C of the retort, and allowed to burn on the bars where the coal fire was started, and the products of combustion surrounded the retort in their passage through the oven C<sup>1</sup> to the flue C<sup>2</sup> leading to the chimney. The air supplied for the combustion of the spent shale was admitted through the perforated iron boxes *d*<sup>2</sup>, which were secured to the furnace doors *d*. The "burnt" shale dropped through the grate-bars into the ashpit E, and some were also occasionally removed through the furnace doors. This retort being circular in shape and large in diameter was a backward step in economical retorting, but the principle of its working embodied the principles on which the Henderson retort and the coal or heating retort of Young and

Beilby's shale retorts were later constructed. As must be apparent, McBeath's idea was to distil the shale by

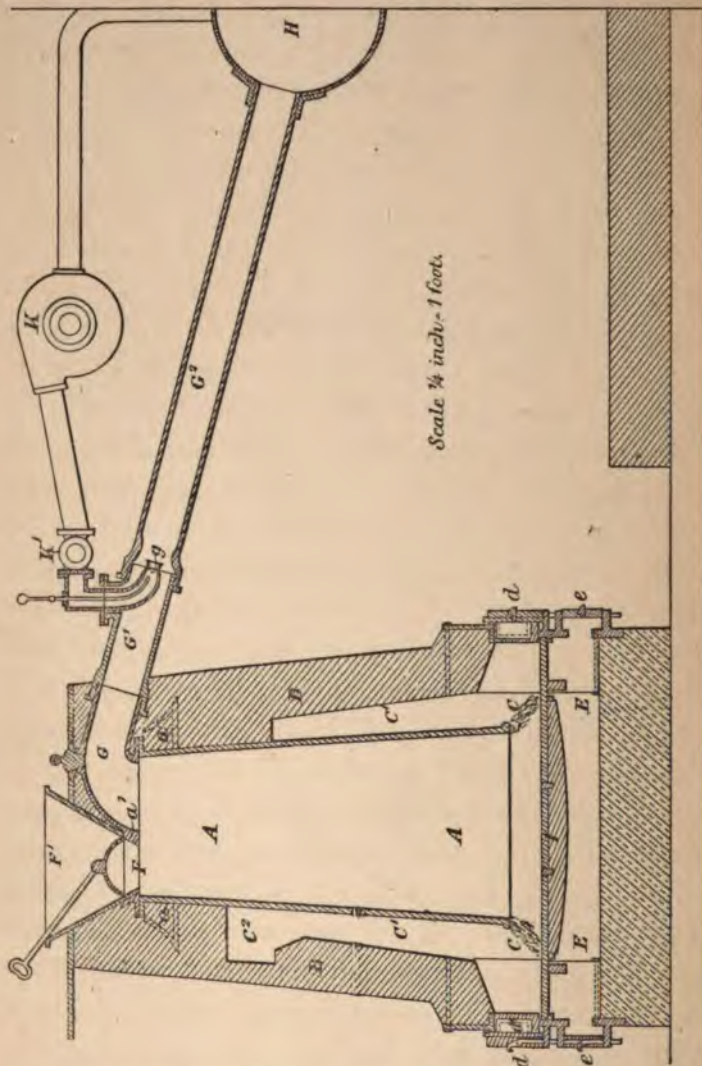

means of the heat derived from the combustion of the carbon left in the spent shale. He saw that in order

to accomplish this with his apparatus, there was a probability that the products of distillation would be drawn downwards by the draught of the chimney and be consumed in the furnace, and therefore he introduced the steam injector and fan blower with a view to counteracting this draught. Knowing that too great a suction on the vapour pipe would be as detrimental to the yield as an uncounteracted draught towards the chimney, by causing the fire to be drawn up into the retort, he had the vapour pipe G cast with an opening on the top into which fitted an iron plug. The periodical removal of this plug and introduction in its place of a water gauge showed how the suction there compared with the known draught of the chimney, and if there was any difference it was easily corrected by means of either the injector or blower.

Having noted this special step towards economy in shale distillation, we will now look at the construction and working of the "Henderson" retort, which type enjoyed a full share of patronage for many years.

The principal features of the Henderson retort are the utilisation of the carbon in the spent shale and the gas resulting from the distillation as fuel, and, also, the adoption of a downward distillation. As the natural tendency of oil vapours is to rise, it was considered that making them travel in a direction contrary to their natural one—by driving them downwards through the shale contained in the retort—would have the effect of partially purifying them and giving a better quality crude oil; how far this theory was correct will be shown shortly. (See p. 80.)

The retorts A, Fig. 10, were made of cast iron with an elliptical cross section, and were placed in a vertical position in an oven B that was common to four of them.

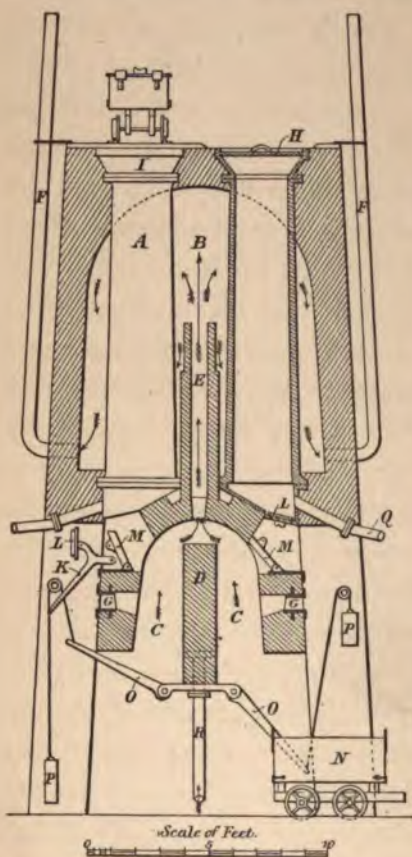

FIG. 10.

through the furnace doors G—and when the retorts had attained the proper heat, one of them was filled with shale by removing the cast-iron cover H of the hopper I. After the lapse of four hours, another—of the set of four

The oven was heated by the two furnaces C, and each furnace was common to two retorts. The two furnaces were separated by the dividing wall D, and the products of combustion were conducted upwards through the flue E and discharged into the oven at a point about half-way up the retorts, and then had to take a downward course before they could escape through the iron chimneys F. To start these retorts it was first necessary to light a coal fire in the two furnaces—supplying the fuel

retorts—diagonally opposite to the first \* was charged, and so on until the four retorts were filled, and every five hours thereafter one of the set was emptied and recharged in the order in which it was filled. In that way the shale remained sixteen hours in the retort before the time for recharging that retort came round again, and after that time had expired a tool K, called “the monkey,” was placed so that its short arm engaged in the plate L that closed the bottom of the retort, and, while being held in this position by an upward hand-pressure on its long arm, the iron wedges that held the plate in place were loosened and removed, and then, by lowering the long arm of the monkey, the plate was carried over to the position shown on the left-hand side of Fig. 10. But before the plate was thus lowered, the upper furnace door M was placed under control by means of a long-handled hook, and as the plate was being removed from its place it was closely followed by the door M, which latter, in its new position, acted as a guide for the shale descending from the retort to the furnace below.

Supposing that (1) in Fig. 11 was the retort just recharged, then the time for recharging (3) would be eight hours later, and as the retort could not be discharged until the furnace below it was emptied, it follows that the spent shale from a retort acted as fuel for a space

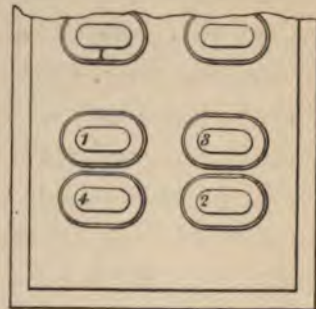

FIG. 11.

\* See plan of the retorts, Fig. 11.

of eight hours. In order to empty the furnace, an iron truck N, called a "hutch," was run under it, and then the long arm of the grating O was pulled down and the burnt shale allowed to fall into the hutch. After the furnace had been thus emptied, the grating was carried back to its former position by the counter-balance weight P.

The products of distillation left the retort through the connection Q, and after the gas had been freed from oil, &c., it was returned through the pipe R and burned in the furnace for fuel.

These retorts effected a great saving in labour over the old form of vertical retorts. In the first place, instead of dumping the shale on a platform, and then shovelling it by hand into the retorts, the latter were so constructed that a set of rails could be permanently laid over the top of them, and hutches containing the shale travelled along these rails and simply had to be tipped over an open retort in order to charge the latter. The discharging of the furnace was equally expeditious, and the hutch full of burned shale was removed by an endless chain and required but little manual labour.

Ten men were able to put through 65 tons of shale with the Henderson retorts, while the same amount of shale required 14.5 men with the old vertical retorts; or about two men for the former, for three for the latter.

The coal required for working the Henderson retorts was about 2.5 cwt. per ton of shale distilled, and of this about 1.5 cwt. was used in the retort fire chamber and the other 1 cwt. in raising the steam (in the boilers) used in the retorts and driving the

machinery in connection therewith. Therefore, the amount of coal necessary to run the Henderson was only about one-half that needed for the old vertical retorts, and was due to the use as fuel of the gas given off during the distillation; and it was also supposed to be largely due to the utilisation as fuel of the carbon left in the spent shale. Of course the spent shale from the old vertical retorts could not be used as fuel, owing to it having been drawn through the water trough at the bottom of the retorts and rendered too wet to burn; but even the utilisation of the spent shale from the Henderson retorts as a heating medium was certainly, in the manner in which it was done, a backward step in economy rather than otherwise. As shown in Fig. 10, the gas for combustion was distributed in the furnace close to the bottom, and had to burn its way upwards through the shale. It is quite evident that here was a weak point in the heating arrangements, because the spent shale when dropped from the retort was comparatively cold, that is, it was not above a black heat, and therefore it required a large amount of the heat evolved by the combustion of the gas before it imparted any heat itself to the retorts. It is therefore apparent that if the gas was led into the furnace at a point above the spent shale, the whole of the heat that had been required for heating the spent shale to combustion point would be saved and utilised for heating the retorts, while, at the same time, the spent shale lying in the furnace would impart considerable heat to the air, necessary for the combustion of the gas, as it passed up through it. The author examined the gas burned under the



retorts with a view to determining whether its calorific power was sufficient to maintain the required heat for the retorts if utilised in the manner just referred to. The results of a larger number of determinations proved conclusively that the calorific power of the whole of the gas from one retort was a good deal more than sufficient to maintain a distilling heat on that retort for the required period of sixteen to seventeen hours, but as the retorts are not touched, as regards charging, from Saturday afternoon until Sunday afternoon, the shale has by that time ceased to give off gas, and therefore coal would require to be burned in the furnaces for about twelve hours, starting at midday Sunday. By adopting this method of burning the gas, the coal consumed in the retort furnaces could be reduced to 0·5 cwt. per ton of shale distilled.

The one objectionable feature in the construction of these retorts was the constant emitting of noxious gases from the short chimneys, thus seriously polluting the atmosphere in which the retort attendants had to work. At some of the works, these short chimneys were connected into a flue common to them all, passing along the side of the retort bench and leading to a tall brick chimney. There is one thing in favour and one against this latter method of disposing of the noxious gases, and, looking at it in a favourable light, it is at once apparent that it rids the atmosphere in the immediate neighbourhood of the retorts of the sulphurous and carbonic acid gases, and therefore makes it healthier for the men employed at the retorts; but, looking at it in the other light, we see that the purpose for which the

short chimneys were meant—to prevent overheating by having too great a draught—was practically frustrated, because the draught of a tall stack is far more liable to variations than that of a short one, owing to its high altitude, and necessitates the employment of extra attendants to watch the heat and regulate the dampers.

TABLE X.

Hour after Charging.	Hourly Yield of Crude Oil in Gallons.		Hourly Yield of Ammonia (expressed as Sulphate) in lbs.	
	No. 1 Shale.	No. 2 Shale.	No. 1 Shale.	No. 2 Shale.
1st	Nil	0·993	4·010	2·137
2nd	0·96	1·325	2·811	1·441
3rd	1·85	1·987	0·561	0·701
4th	2·69	3·200	0·463	0·420
5th	3·16	3·646	0·330	0·343
6th	3·50	3·706	0·464	0·449
7th	4·06	3·500	0·515	0·547
8th	2·81	2·750	0·739	0·633
9th	2·25	2·090	0·980	0·601
10th	2·03	1·250	0·932	0·525
11th	1·94	1·250	0·572	0·759
12th	1·22	0·500	0·586	0·712
13th	0·86	0·385	0·462	0·569
14th	Nil	Nil	0·364	0·528
15th	Nil	Nil	0·405	0·448
16th	Nil	Nil	0·387	0·416
17th	Nil	..	0·165	..
<b>Total</b>	<b>27·33</b>	<b>26·582</b>	<b>14·746</b>	<b>11·229</b>

The shale charged into a Henderson retort weighed 17 cwt., and by referring to Table X. we can follow the progress of the distillation of that weight of shale from the start to the finish.

We see by this last table that the shale yields up all its oil by the end of the thirteenth hour, and that the further continued retorting results in the production of ammonia only. As stated some pages back, the whole of the ammonia is not obtained from the shale until the carbon in the latter has been entirely eliminated, and therefore the shale in a Henderson would continue giving off a small quantity of ammonia for some days, because the heat is not sufficient to eliminate the nitrogen (that forms the ammonia) rapidly enough to exhaust the supply any sooner. The value of the ammonia obtained by continuing the retorting after sixteen hours have elapsed, is small as compared with the extra cost and outlay of apparatus that would be necessary, and therefore it is cheaper to content oneself with a smaller yield of ammonia, and confine the shale in the retort for only sixteen hours.

The life of the Henderson retorts of course largely depends upon the usage they get, and the practice of some companies of working their retorts by contract cannot be too strongly condemned. The man who has the contract, being paid according to the yield, increases the heat on the retorts (as soon as the oil has distilled off) in order to obtain as large a yield of ammonia as possible, and by so doing he greatly shortens the life of the retorts, and cases are known where they have only lasted for three years where the work has been done

by contract. On the other hand, retorts that have received careful handling have been known to be in as good condition after five years' constant use as when first erected.

A comparison of the yields, &c., of the products from the old vertical and Henderson retorts will here be of interest, and is shown in Table XI.:

TABLE XI.

Henderson.			11-foot Vertical.			15-foot Vertical.		
Crude Oil.		Lbs. Sulph. Ammon.	Crude Oil.		Lbs. Sulph. Ammon.	Crude Oil.		Lbs. Sulph. Ammon.
Sp. Grav.	Gallons.		Sp. Grav.	Gallons.		Sp. Grav.	Gallons.	
872	23·29	13·07	874	20·92	16·24	877	27·17	18·91
869	23·21	10·32	876	22·70	19·20	873	21·86	15·81
869	22·96	10·12	879	21·10	17·80	877	27·00	19·30
867	20·78	6·93	881	23·14	19·12	876	23·79	20·44
869	20·84	8·46	876	22·66	20·21	875	24·52	17·50
870	23·88	10·34	884	24·56	23·26	875	24·33	18·19
874	22·41	12·81	881	23·49	20·97	872	23·21	12·33
872	21·34	10·09	883	21·74	21·88	877	26·71	22·54
870	23·57	11·65	880	21·97	18·10	875	27·01	16·18
Aver.	22·47	10·31	..	22·47	19·64	..	25·06	17·91

The shales used in obtaining the above tabulated results were charged into the retorts, so that both the Henderson and vertical received practically the same shale in each test, and we therefore see that while the Henderson gave the same average yield of oil as the

11-foot vertical retort, it gave only about one-half the yield of ammonia. Also, an increase in height of 4 feet in the vertical retorts, while beneficial to the yield of oil, seemed to be disadvantageous for the production of ammonia. These figures appear to be decidedly in favour of the regular 11-foot vertical retorts, when we consider that sulphate of ammonia is one of the most valuable products; but we shall see that the use of the Henderson in place of the vertical retorts yields larger profits. Henderson claimed that his retort gave a purer oil and therefore larger yield of finished products, and by turning to Table XII. we see that that claim was a decidedly correct one.

TABLE XII.

Finished Products.	Crude Oil.		Crude Oil.	
	Vertical.	Henderson.	Vertical.	Henderson.
Naphtha . . . .	Nil	1.50	5.00	5.00
Burning oils . . .	41.45	44.36	33.30	36.83
Intermediate oil . .	4.59	1.64	6.00	3.00
Crude scale. . . .	11.64	13.00	9.26	10.48
Lubricating oil . .	16.66	17.12	15.40	17.26
Total per cent.	74.34	77.62	68.96	72.57

Not only did both the above comparative results from two kinds of shale\* show an increased total yield of finished products, but there was also a large increase

\* The yields of crude oil from both the Henderson and vertical retorts were practically the same.

in the percentage of crude scale in the Henderson crude oil over the vertical, and this was a most important point in favour of the former.

A short summary of the foregoing facts shows :—

1. That the Henderson retorts required only one-half the fuel that the vertical needed.
2. That the Henderson retorts required only two-thirds of the labour that the vertical required.
3. That the Henderson gave only one-half the yield of ammonia that the vertical retorts gave.
4. That the yield of crude was practically the same from both retorts.
5. That the yield of finished products was 3 per cent. larger from the Henderson than from the vertical crude oil.
6. That the yield of crude scale was 1·3 per cent. larger from the Henderson than from the vertical crude oil.

Taking all the above facts under consideration, we find that, from a "profit" point of view, there is a decided balance in favour of the Henderson retorts.

The next retort that came into prominent notice was Beilby's, and its general construction can be followed by referring to Fig. 12, in which the side elevation of two retorts is shown. The chamber B, surmounted by the hopper A, was common to four of the cast-iron retorts B<sup>1</sup>, and the lower ends of the latter were jointed to the fire-clay cylinders C and D, while the lower end of D was jointed to a short cylindrical iron casting E, which continued down below the surface of water contained in the trough F. The retorts were heated by

means of a furnace, not shown in the illustration, and the furnace fires first passed into the chamber G and then up into the intermediate chamber H, from which they escaped to the chimney. The upper chamber I

was heated partly by radiation from the one below, and partly by burning sufficient gas in it to maintain the "upper" retort B' at an incipient red heat. The products of distillation passed away to the main L through the connection K.

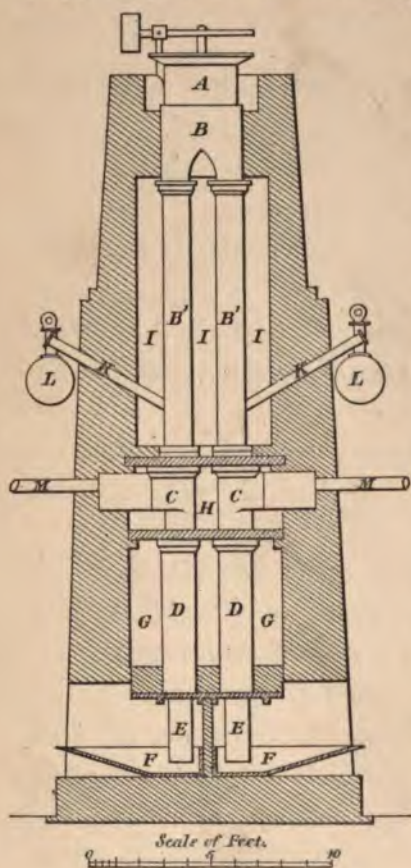

FIG. 12.

of its nitrogen was there eliminated. Of course the dropping of the shale from one portion of the retort to the other was done progressively, and in much the same manner as in working the old vertical retorts.

In working these retorts the fire-clay portion was at a bright red heat and the iron portion at a low red or almost black heat. The shale was deprived of its volatile matter in the iron retort, and when it passed down into the highly heated clay retort the greatest portion

By the use of the Beilby retort the oil was distilled from the shale at a low heat, and the most of the ammonia was produced by subjecting the spent shale to a very high heat, and thus the conditions required for the conjoint production of maximum yields of both oil and ammonia were to a large extent obtained. However, the adoption of these retorts was nearly the ruin of some of the oil companies. The fire-clay portions not being capable of withstanding the sudden alteration of temperature caused by a comparatively cool shale, from the iron retort, being brought in contact with their highly heated surfaces, resulted in their never being long at work before they cracked, and, as soon as that happened, the furnace fire was not long in finding its way into the retort and causing explosions. This form of retort, therefore, could not be called a "working" success, and, as it could not be worked economically as regards labour, it went entirely out of use about the year 1883. The average yield of products from the Beilby retorts as compared with the Henderson and old vertical was lower as regards crude oil, but very much higher as regards ammonia, as will be seen by looking at Table XIII.

TABLE XIII.

Product.	Yield from		
	Vertical Retorts.	Henderson Retorts.	Beilby Retorts.
Crude oil (per ton) .	23·49 gals.	23·27 gals.	21·05 gals.
Sulphate of ammonia } (per ton) . . . }	20·97 lbs.	11·57 lbs.	30·36 lbs.



Table XIV. shows how the yield of finished products from the Beilby crude oil compared with the other two, and from it we see that the results are very much in favour of the former, which, although giving one per cent. less total finished products, gave nearly 2·5 per cent. more crude scale than the Henderson crude gave.

TABLE XIV.

Finished Product.	Vertical Crude.	Henderson Crude.	Beilby Crude.
Naphtha . . . . .	5·00	5·00	2·00
Burning oil . . . . .	33·30	36·83	33·86
Intermediate oil . . . . .	6·00	3·00	5·00
Crude scale . . . . .	9·26	10·48	12·94
Lubricating oil . . . . .	15·40	17·26	17·36
Total per cent.	68·96	72·57	71·16

While Henderson and Beilby were designing retorts, William Young was also working in the same direction, and produced a retort that was constructed on very much the same principle as Beilby's, only that it was made of cast iron throughout. The lower casting that was subjected to the high heat was soon burned through and rendered useless, and the retorts, therefore, were never used except experimentally.

Seeing good points in each other's retorts, Young and Beilby put their heads together and conjointly produced a retort \* that has practically superseded all other

\* Often called the Pentland retort.

forms. The front elevation of these retorts is shown in Fig. 13, while Fig. 14 is a side elevation of the shale retorts, and Fig. 15 a side elevation of the coal retort and steam superheater. The distilling chamber A (Figs. 13 and 14), which is made of cast iron, is common to four oil retorts B, which latter are also made

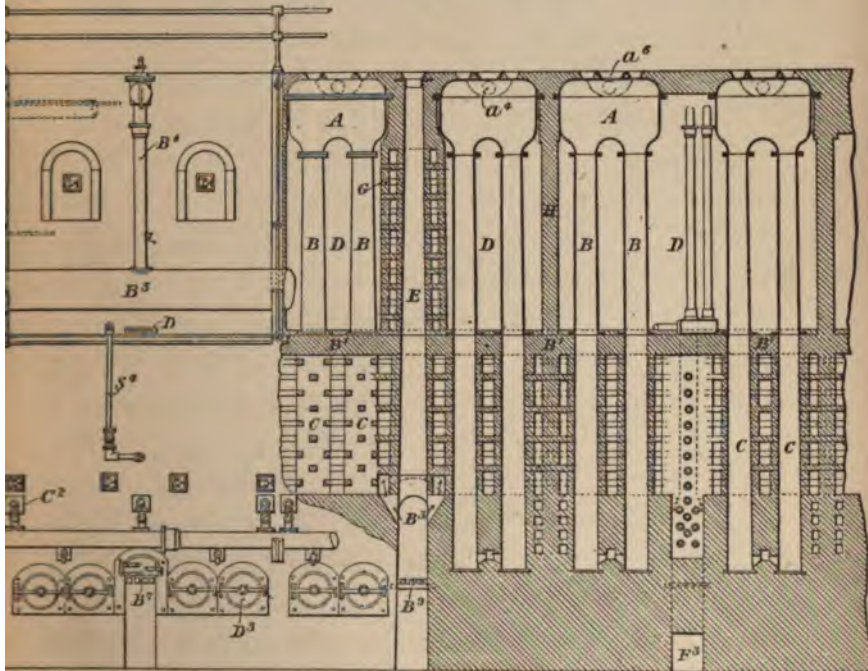

FIG. 13.

of cast iron and are jointed at their lower ends to the ammonia retorts C, which latter are built of fire-brick.

It is claimed by the patentees, that by using this composite form of retort the crude oil receives a partial purification in the distilling chamber A, which renders the first, or crude oil distillation, unnecessary, and thus

effects a large saving in cost of refining. This partial purification is said to be effected thus :—

“The superheated steam, gases and ammonia pass from the high-heated retort up through the shale or low-heated retort, assisting in the destructive distillation and the elimination of the oil in the form of vapour. The whole of the combined oil, water vapour, gas and ammonia pass up through the cold shale in the chamber above, causing the condensation of the oil vapours, and at the same time heating the shale. This condensation continues so long as the temperature of the shale remains sufficiently low, and the shale being covered with the oil vapours, entangles all mechanical impurities which would be carried forward with the oil. As the temperature of the shale in the chamber gradually increases by the continuous flow of the heated gases and vapours through it, the more volatile of the previously condensed oils revolatilise, and as the temperature goes on increasing, the less and less volatile of these oils are evaporated, until by the time the distillation of the shale in the low-heated retort is completed, the last traces of the previously condensed oil are revolatilised and the shale heated to a temperature approaching the point of decomposition.”

The above extract from Young and Beilby's specification exactly explains what takes place in every form of vertical retort, but it has been found in practice that crude oil from even the Young and Beilby retorts cannot be properly refined unless it receives the preliminary distillation, and therefore the cost of that part of refining is not saved.

The most novel thing about the retorts is the heating arrangements. Sixteen of the composite retorts are inclosed in two ovens D, and between the latter is placed the coal retort E (Figs. 13 and 15). This coal retort is constructed of fire-brick and its lower half is provided with a number of pigeon-holes that open into the two ovens, and its lower extremity ends on grate-bars, and is provided with a furnace door. Supposing everything to be in working order when the coal retort is charged, the coal coming in contact with the hot sides of the retort and the superheated steam and gases (which are kept constantly passing upwards) immediately begins to produce gas and ammonia, and these together with the other gases, and steam, are

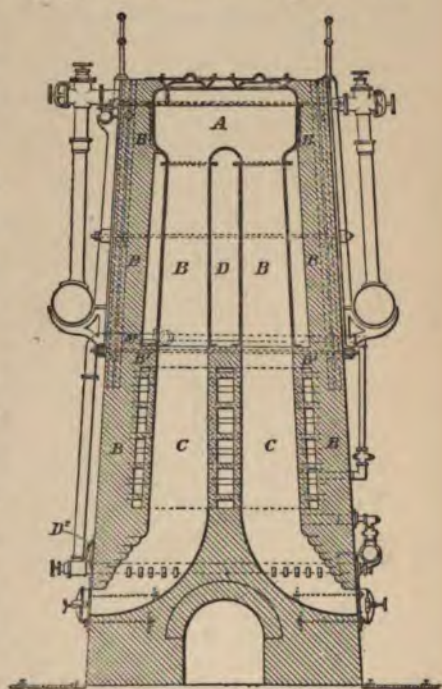

FIG. 14.

drawn off at the top of the retort into a main B (Fig. 15), and after the ammoniacal steam has been condensed and separated from the gases, the latter are returned to the retort and enter near the bottom. One portion of the returned gases again goes through the process just described, while the other portion is drawn through the

pigeon-holed brickwork into the oven D (Figs. 13 and 14) surrounding the retorts, and is there consumed as fuel for heating the coal retort, sixteen shale retorts and the steam superheater C (Fig. 15). The coal retort is worked so that the draught in the flues of the oven as near as possible counterbalances the slight vacuum

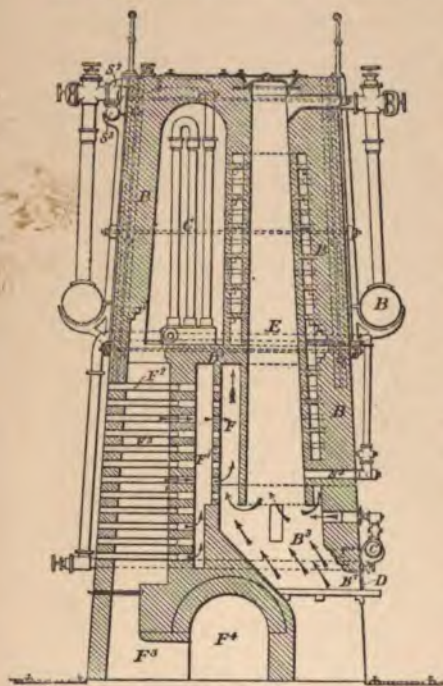

FIG. 15.

maintained in the retort and connections leading to the exhauster, and in that way the gases generated in the upper portion of the retort can be drawn off without danger of the fire being drawn up in at the lower end; in fact this coal retort is worked in a very similar manner to that already described for working McBeath's shale retort. By the time the coal has worked its way down in the retort and reached the grate-bars it is reduced to ashes, and the latter are periodically removed through the furnace door D (Fig. 15). This method of handling the fuel for the shale retorts results in the most of the ammonia, contained in the coal, being secured, whereas by the former methods of heating this ammonia was entirely lost.

The Young and Beilby retorts are like most others

as regards their length of life, and if placed in the hands of careful workers and, more especially, if not worked at too high a heat, they should last from six to seven years; but if worked with the view of obtaining the maximum yield of sulphate of ammonia from the shale and, therefore, at a very high heat, they will last but two or three years at the most. In the long run, therefore, it is cheaper to sacrifice a little ammonia and thus lengthen the life of the retorts.

It is very hazardous to allow these retorts to cool down, as the cooling causes the joint between the cast-iron and fire-brick portions to open, and the joint cannot be effectually closed again without pulling down and rebuilding the brickwork. It is therefore necessary to keep these retorts constantly working, and the old customary rest from Saturday afternoon until Sunday afternoon cannot be indulged in. The retorts are charged every six hours, and the weight of the charge is 7 cwt., and a retort distils 28 cwt. of shale per twenty-four hours. Before the retorts are charged a quantity of spent shale (equal to the charge) is withdrawn to an iron hutch from the "ammonia" portion by opening the door D (Fig. 14).

The Young and Beilby retorts now in course of construction at some of the works are built entirely of brick, and have a round cross section of 36 inches in diameter at the bottom and 24 inches at the top, and a height of 50 feet from the ground to the top of the retort. The results obtained from some of these enormous retorts that have just been put into operation are said to be very satisfactory indeed.

The cost of running the Young and Beilby retorts compared very favourably with that of the Henderson retorts, and the yields from the former are very considerably in their favour, as will be seen by referring to Tables XV. and XVI.

TABLE XV.

Product.	Hender-son.	Young and Beilby.	Hender-son.	Young and Beilby.	Hender-son.	Young and Beilby.
Crude oil (gals.)	34·18	30·26	23·60	22·83	28·72	26·15
Sulphate of ammonia (lbs.)	12·34	44·76	11·70	45·11	10·93	43·55

The results of the distillation of three different shales as given above, show that the Henderson retorts give a somewhat larger yield of crude oil, but only about one-quarter ( $\frac{1}{4}$ ) of the yield of ammonia that the Young and Beilby retorts give.

TABLE XVI.

Finished Products.	Crude Oil, from	
	Henderson.	Young and Beilby.
	per cent.	per cent.
Naphtha . . . . .	2·00	0·75
Burning oil . . . . .	41·80	34·27
Intermediate oil . . . . .	1·02	4·50
Crude scale . . . . .	10·87	13·57
Lubricating oil . . . . .	17·36	20·55
<b>Total . . . . .</b>	<b>73·05</b>	<b>73·64</b>

Looking at Table XVI. we see that the total yields of finished products are almost identical in both cases, while the yield of crude scale is  $2\frac{3}{4}$  per cent. and lubricating oil  $2\frac{1}{8}$  per cent. larger from the Young and Beilby than from the Henderson retorts.

The yields of crude oils, from which the finished products in Table XVI. were obtained, were:—

Henderson, crude . . . .	34·18 gallons per ton.
Young and Beilby, crude	30·26     ,,     ,,

If by the use of these figures we calculate the percentage figures of the scale and lubricating oil in Table XVI. back to the shale, we find that the figures are still in favour of the Young and Beilby retorts, as is shown in Table XVII.

TABLE XVII.

Product.	Yield in Gallons from One Ton of Shale.	
	Henderson.	Young and Beilby.
Crude scale . . . . .	3·715	4·106
Lubricating oil . . . . .	5·933	6·222

The yields of 0·391 gallons of crude scale and 0·289 of lubricating oil per ton in favour of the Young and Beilby retorts, together with the enormous increase in the yield of ammonia, has naturally resulted in these retorts practically superseding all others.

One often hears, when in the neighbourhood of the oil



works, of tremendous yields of sulphate of ammonia that such and such a company is obtaining, the reported yield often being as high as 80 lbs. per ton. Such apparently large yields are invariably accounted for by the fact that the company, instead of employing an overseer at the pit head to reject any inferior shale that may be loaded on to the railway wagons, prefers rather to make allowances for any inferior shale that may be so loaded, by figuring a ton as weighing anywhere from  $20\frac{1}{2}$  to 24 cwt., and, therefore, when the company that boasts of a yield of 70 lbs. of sulphate of ammonia per ton of shale is retorting a 24-cwt. ton, the yield per actual ton is only  $58\frac{1}{3}$  lbs. Also, as the ammonia water from the Young and Beilby retorts contains a large amount of oily bases, the apparent amount of ammonia present in it greatly exceeds the actual amount unless special precautions are taken in making the analytical determinations, as will be explained under the heading "Laboratory."

No matter what form of retort is used, it is absolutely necessary for their safe working that the gas mains shall be well supplied with explosion doors. These doors are made by leaving an opening, about 12 inches in diameter, in the top of the main and surrounding it with a water lute into which fits an iron cover. The cover has about 3 feet of chain attached to it, and the other end of the chain is secured to the main. In the case of explosions—which at times occur quite frequently—the iron cover to the lute is blown off and affords immediate relief to the main, while the chain prevents the cover being blown any great distance and temporarily lost.

The auxiliary apparatus necessary for the distillation of shale consists of :—

1. Steam boilers for supplying steam for the retorts as well as running the machinery in connection therewith.

2. A condenser.

3. An exhausting fan or pump.

4. A scrubber or coke tower for freeing the gas of its volatile oils.

5. An apparatus for recovering the volatile oils from the coke towers.

6. Separators, for separating the ammoniacal water from the oily products.

7. Receiving tanks for the various crude products.

8. A pond for cooling or quenching the spent shale when after it comes from the retorts and before it goes to the waste shale bank.

The amount of steam used in the Henderson and old vertical retorts amounted to an equivalent of about 60 gallons of water per ton of shale, while in the Young and Beilby retorts about 110 gallons of water (in the form of steam) are used per ton of shale. The pressure of the steam for the Henderson retorts was not to be below 10 lbs. per square inch, while the steam used in the Young and Beilby retorts is not to exceed the pressure of a column of water 6 inches high.

The use of such low-pressure steam in the Young and Beilby retorts led Mr. McCutcheon, of Young's Company, to suggest, about nine or ten years ago, that the main flue from the retorts be so constructed that the exceedingly large amount of waste heat could be utilised

for generating steam for use in the retorts. This very excellent suggestion, which would entail but a comparatively small outlay of capital and would save a very large sum of money per annum in coal bills, has, so far as the author has been able to learn, not yet been adopted.

The amount of vacuum maintained in the retorts, mains, &c., by means of the exhauster is usually equal to a column of water  $1\frac{1}{2}$  to 2 inches in height.

The condenser used in connection with the retorts is usually of the type known as an "Air Condenser," and, as the name implies, the cooling medium is air. The air condenser, shown in plan in Fig. 1, requires to be examined in detail in order to thoroughly understand its construction and method of working, and therefore we will refer to Figs. 16, 17 and 18. It is composed of a series of horizontal manifolds or "chests" A, B and C connected with each other by means of the pipes E, F and G. The first chest A into which the gas and vapours from the retorts first pass is 2 feet in diameter by about 30 feet long, and is provided on its upper side with a single row of openings that enable the making of bell and spigot joints. The other manifolds, B and C, are only 18 inches in diameter, but are provided on top with a double row of bells, and divided longitudinally by the partition D, which extends down to within 2 inches of the bottom. An air condenser capable of handling the gas and vapours from 144 Henderson retorts usually consists of one manifold like A, eight piped like B, and one piped like C. After the gas and vapours have filled A, they

END ELEVATION.



FIG. 16.

SIDE ELEVATION.

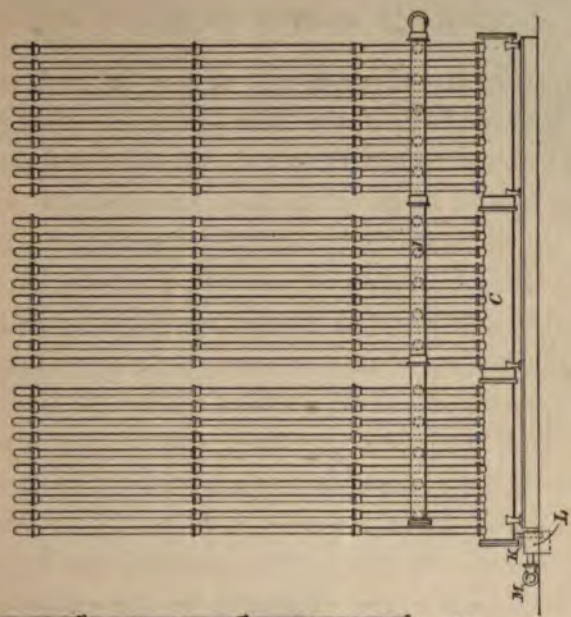
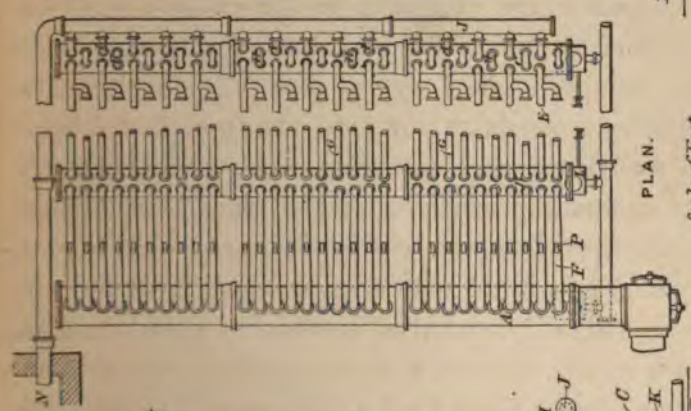

FIG. 18.



PLAN.

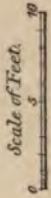

FIG. 17.

pass upwards through F, and over and down into the manifold B, where they have to pass under the partition D before they can ascend the next series of pipes G, and so on until they have passed through the eighth B-manifold, by which time their bulk has been so reduced that two of the pipes E can be connected together and descend to the manifold C, as one. The draining pipe K of manifold C is arranged so as to maintain a depth of about 4 inches of liquid in the manifold, and the gas, &c., descending through the pipes E, being unable to pass under the partition D, have to ascend to the other side of the partition before they are able to escape through the pipes I to the main J which leads to the exhauster in the exhaustion house N. Each of the manifolds with the exception of C is kept thoroughly drained by the pipe K, through which the condensed products run into the traps L and then to the separators, and finally to the respective tanks for the different products. As the pipes F are liable to become choked in the top bends an opening is provided at P and fitted with a cover which can be easily removed and allow of the introduction of an iron rod with which to free the bends of an obstruction. The traps L are provided for the purpose of preventing the escape of gas, and are simply vessels in which the liquid is maintained at a height of about 6 inches above the bottom of the pipe K, thus forming a lute or seal.

As the oil vapours from the retorts consist of a gradation from light to heavy products, it is natural that the heavy or higher boiling point products should

condense first and that the condensed products should get lighter and lighter at each succeeding manifold. This diminution in the specific gravity of the oil condensed in the respective manifolds and their piping enables the oil to be separated into two products, viz. Crude oil and "Air-Condenser" naphtha. In the summer the first five manifolds yield crude oil and the last five naphtha, while in the winter the crude oil is all condensed by the time the vapours pass through the second manifold, and therefore the succeeding eight are used for the condensation of the naphtha. All the manifolds yield more or less ammoniacal water.

We now see that the air condenser separates the gas and vapours into four products, viz. :—

Crude oil.

Air-condenser naphtha.

Ammoniacal water.

Gas (containing very volatile oils).

In order to separate the mixture of crude oil and ammoniacal water, and air-condenser naphtha and ammoniacal water, the mixtures are run through their respective separators.

The separator usually consists of a cast-iron cylindrical tank similar in section and plan to Figs. 19 and 20, in which the separator A is provided with a partitioned space C, which extends down to within 3 inches of the bottom. As water is heavier than oil, when the mixture of oil and water runs into the separator from the pipe E, the water sinks to the bottom and then passes up the partitioned space C and overflows at D,

while the oil remaining on the surface of the water runs off through B.

As a separator is often needed for some experiment that does not justify the expense of having a casting made, the author has shown in Fig. 21 a separator that can be constructed for a very small cost. It consists of the tank \* A, at the bottom of which is cut a hole to accommodate the pipe B, while the pipe C is let into the tank near the top. It is almost unnecessary to state that the water escapes through B and the oil through C.

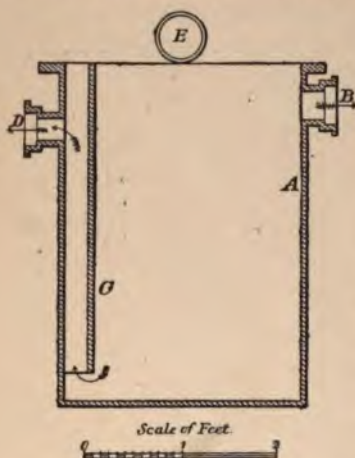

FIG. 19.

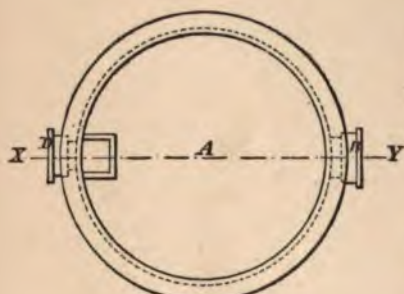

FIG. 20.

Of course the size of the separator depends largely on the volume of the fluids it has to take care of, but whatever the size it is always advisable to build it as deep as circumstances will allow, as depth and not diameter is

the principal requisite for a good separator.

Having separated the oil and aqueous products, we

\* Any old tank or piece of large-sized pipe will answer the purpose, or a galvanised iron vessel with soldered joints can be cheaply constructed.

will dispose of the crude oil and ammoniacal water in the mean time, by saying that they are pumped to their respective storage tanks, and confine our attention to the disposal of the air-condenser naphtha and the gas.

*Air-Condenser Naphtha.*—The yield of this product varies from 1 to 4 gallons per ton of shale, and its specific gravity varies from  $\cdot 708$  to  $\cdot 770$  according to the

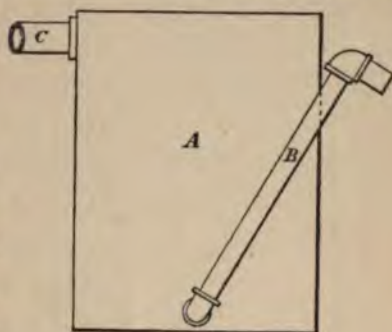

FIG. 21.

efficiency of the condensers. Its semi-purification is effected by distillation in a horizontal cylindrical iron still of about 2000 gallons capacity. The heat necessary for the distillation is obtained solely from steam, which latter is introduced through a perforated pipe lying on the bottom of the still, and, passing up through the oil, heats and vaporises the light naphtha contained in the latter. The distillation is continued until the specific gravity of the distillate stream reaches  $\cdot 768$ , and when that point is reached the steam is shut off from the still, and the residue left in the latter, having a specific gravity of about  $\cdot 850$ , is pumped to the crude oil storage tank. The yield of distillate from air-condenser naphtha varies from 40 per cent. to 70 per cent.; this distillate is mixed with the naphtha that is obtained during the process of refining the crude oil, and will be referred to later as "Air-Condenser semi-refined naphtha."



*Gas.*—The temperature of the gas as it leaves the air condenser of course varies with the temperature of the atmosphere, but it is usually about  $10^{\circ}$  to  $15^{\circ}$  F. higher than the atmospheric temperature, but in cases

where the condensing capacity is somewhat insufficient, these figures are greatly exceeded.

After the gas has passed through the exhauster house it is discharged into the coke tower or scrubber shown in Fig. 22. The tower consists of an iron cylindrical tank A, about 9 feet in diameter by 40 feet high, placed on end and provided with a perforated false bottom B, which

supports the pieces of coke C. The latter should be good hard gas-house coke, free from all dust, and is piled in the tower to a height of about 30 feet. Near the top of the tower is placed a

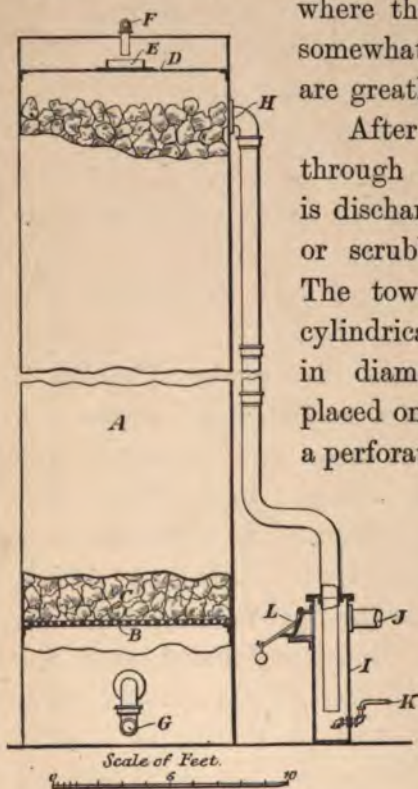

FIG. 22.

perforated or "distributing" plate D, surmounted by a receiving cup E, into which a heavy oil is discharged from the pipes F. When the tower is in operation the donkey pump B (Fig. 23) keeps a constant supply of heavy oil discharging into the cup E, from which it overflows on to the distributing plate D and then runs

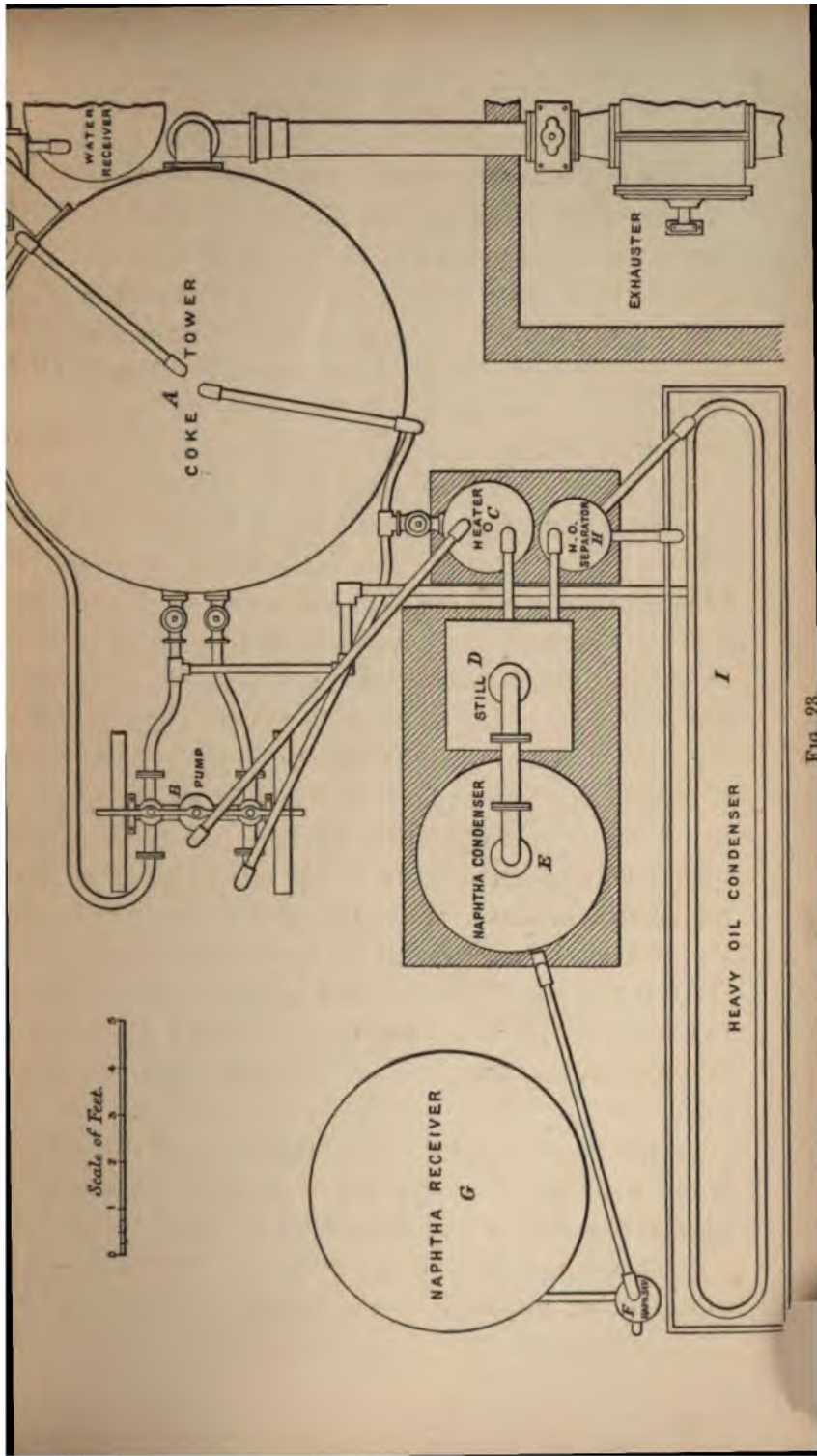

FIG. 23.

down over the surface of the coke C into the lower portion of the tower, from whence it runs to the suction of the pump. The gas entering at the connection G passes upwards and around the pieces of coke, and has to come in intimate contact with the constant shower of descending oil, which latter absorbs the most of the light naphtha vapours before the gas can escape through the connection H near the top of the tower. After leaving the tower, the gas descends in the trap I, and has to bubble up through 3 or 4 inches of water contained in the latter before it can pass into the connection J leading to the retorts. A small amount of water is kept constantly running into the trap, and that which overflows through the connection K is pumped to the ammoniacal water storage tank, as it is rich in ammonia. Explosions are liable to occur in the gas main J leading from the trap to the retorts, and, if relief was not afforded, these explosions would in all probability wreck the coke tower: therefore the trap is provided with the explosion door L, which, being hinged at the top, cannot be blown away, and always drops back to its place after being raised by any excessive pressure. Having disposed of the scrubbed gas by sending it back to the retorts to be burned as fuel, we will now follow the naphtha that was extracted from the gas, and which is called—

*Coke-Tower Naphtha.*—The extraction of the coke-tower naphtha from the heavy oil just referred to, entails the use of the apparatus shown in plan in Fig. 23, and in elevation in Fig. 24, in which figures A and B being respectively the coke tower and pump,

C is a heater, D the still, E the naphtha condenser, F the naphtha and water separator, and G the naphtha receiving tank; while H and I are respectively the

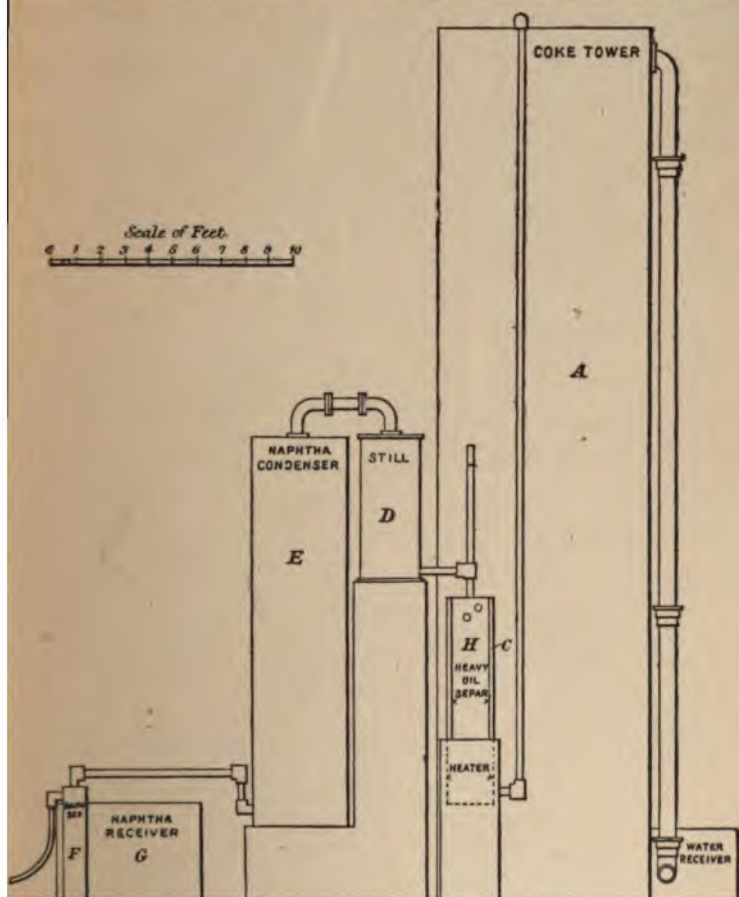

FIG. 24.

heavy oil and water separator and heavy oil cooler. The *modus operandi* is as follows:—

One of the suctions of the pump B draws half of its supply from the heavy oil cooler and half from the

bottom of the tower, and discharges the whole in at top of the tower; while the other suction of the pump draws all its supply from the bottom of the tower and discharges it into the connection leading to the heater, which latter is provided with an automatic feed regulating cock, and any excess of oil discharged into the heater connection is provided with a means of escape by a branch connection leading to the top of the tower. After passing through the heater, the oil is conducted into the still D, where it is brought into intimate contact with live steam, which latter vaporises the naphtha that the heavy oil had extracted from the gas in its passage through the coke tower. The steam and naphtha vapours pass off at the top of the still and into the condenser E, and, having been condensed, they then run through the separator F from whence the water runs to the sewer, and the coke-tower naphtha to its receiving tank.

The heavy oil being freed of the naphtha, passes out at the bottom of the still, and, after having had any water it may have collected separated in H, it continues on to the cooler I, where its temperature is reduced to  $50^{\circ}$  to  $60^{\circ}$  F. before it again passes into the suction of the pump B to renew the cycle of movement just described.

A few words in regard to the construction of some of the above apparatus may be of use. The heater H is composed of a long spiral coil of pipe placed in a tank, into which latter the steam from the pump exhausts. The hot water and steam which this tank contains heat the oil in its passage from *a* to *b* (Fig. 28), and thus effect

a saving in the cost of the distillation—as regards steam. The exhaust from the pump enters the heater through *c*, and any uncondensed steam escapes through *d*, while the condensed water is maintained at a steady level by the connection *e*.

The still D is shown in elevation and plan in Figs. 26 and 27, in which *a* is the oil inlet formed into a square on the inside and provided with an upright pipe *b* at each corner. The four pipes *b* project to

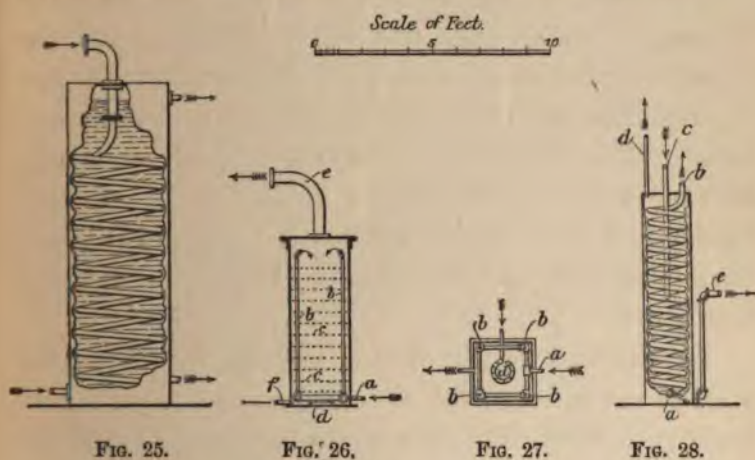

within 9 inches of the top of the still, and the oil overflowing from them trickles down over the wire gauzes *c* and comes in contact with the escaping steam from the rose *d*. The steam, and the naphtha that vaporises from the oil, pass up through the gauzes and out at *e*, while the heavy oil continues on down and out at *f*.

The condenser F is shown in part section in Fig. 25, and is simply an upright cylindrical tank fitted with a spiral coil through which the vapours pass, while cold

water enters at the bottom of the tank and overflows near the top.

The amount of oil that has to pass through the coke tower per twenty-four hours depends largely, of course, on the quantity of gas to be scrubbed, but if the volume of gas is known it is easy to calculate the amount of oil to be circulated, by figuring that two gallons of oil are required for scrubbing every 100 cubic feet of gas.

The Henderson retort yields about 3000 cubic feet of gas per ton of shale, and retorts about  $1\frac{1}{4}$  ton per twenty-four hours. Therefore the three benches of forty-eight retorts each (which the coke-tower naphtha apparatus just described would be easily capable of taking care of) would yield 540,000 cubic feet of gas per twenty-four hours, and consequently the pump B would have to circulate 10,800 gallons of heavy oil per twenty-four hours.

In the case of the Young and Beilby retorts, the yield of gas is from 7000 to 10,000 cubic feet per ton of shale, and consequently a coke-tower naphtha apparatus of the size we are dealing with would be able to take care of only two benches of these retorts of forty-eight retorts to the bench.

The amount of coal required for supplying the steam for the pump, still, &c., for the coke-tower naphtha apparatus amounts on an average to  $15\frac{1}{4}$  lbs. per ton of shale distilled, or about  $1\frac{1}{4}$  ton of coal per twenty-four hours.

Mr. Colman about the year 1875 conceived the idea of extracting the volatile naphtha vapours from gas by

means of compression, and Table XVIII. shows the results of this method of working as compared with the absorption or coke-tower method.

TABLE XVIII.

Yield of Naphtha from 3000 cubic feet of Gas.				
By Compression.			By Absorption.	
Pressure per Square Inch.	Gallons.	Specific Gravity.	Gallons.	Specific Gravity.
150 lbs. . . .	2·81	·693	3·29	·708
” ” . . . .	2·26	·668	2·78	·709
100 ” . . . .	2·46	·708	2·31	·710
” ” . . . .	2·44	·710	2·17	·705
” ” . . . .	2·51	·708	2·46	·708
90 ” . . . .	2·26	·700	1·81	·701
Average . . .	2·46	·698	2·47	·707

Both the compression and absorption methods gave, on an average, almost identically the same results as regards yield, and as the compression method was the more expensive the absorption method was continued.

In the regular way of working, the yield of coke-tower naphtha does not usually exceed 1½ to 2 gallons per ton of shale, but there is an apparatus devised by William Young, that brings up the yield to 2½ to 3 gallons. However, it is exceedingly doubtful whether there is anything to be gained (at the present market



values) by extracting the last trace of naphtha from the gas when, in order to do so, one has to go to the expense of 1000*l.* or so for apparatus and pay a royalty in the bargain. Also, the extra naphtha that this apparatus extracts is of such a very volatile nature that even after it is obtained it is very hard to hold it, and, in fact, before it can be converted into a finished product the most of it has been lost by evaporation. Again, if we extract this last trace of naphtha we rob the gas of a certain amount of calorific power and of the whole of its illuminating power, and it is necessary to use more coal at the retorts in order to replace the loss in calorific power of the gas, and, as gas is largely used for illuminating purposes in the works, it is necessary, in the event of the shale gas being deprived of its illuminating power, to go to the expense of erecting a separate plant for the production of illuminating gas. Under the circumstances, therefore, a company that possesses a plant similar to the one illustrated in Figs. 23 and 24 is not warranted in going to the expense of making any radical and expensive changes in it.

*Cooling Pond.*—Spent shale is at a red to bright-red heat when drawn from the retorts, and the practice of some companies of dumping it in that condition on the waste shale banks should not be tolerated, as the atmosphere for miles around is thereby polluted with noxious gases that destroy vegetation and ruin the crops, not to speak of causing constant discomfort to people living in, or having to pass through, the neighbourhood. There is no excuse for the practice, as the spent shale can be quickly rendered unobjectionable at a small cost by

building a pond between the retorts and the incline leading to the waste shale bank.

The pond A, Fig. 29, is built of brick and cement and provided with a pair of rails on the bottom for the hutches B, full of hot spent shale, are attached to the haulage chain C, by the short chain D, and pulled through the pond of water, and by the time they reach the incline leading to the bank their contents are thoroughly quenched. This process, of course, results in the generation of an enormous volume

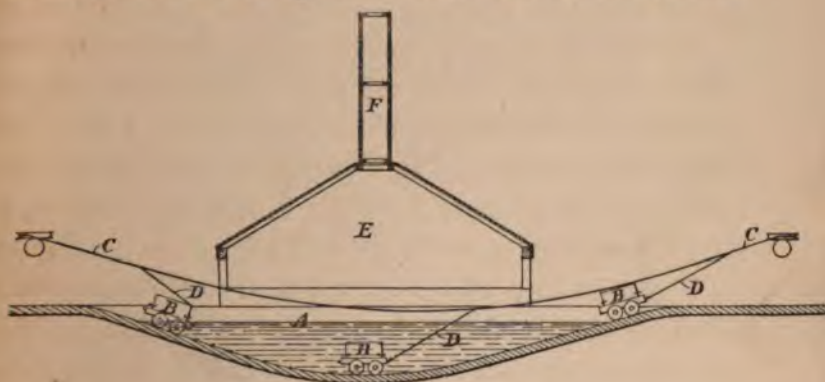

FIG. 29.

of steam, and so that the attendants can see what they are doing, and work expeditiously, it is necessary that the steam be carried off to a point where it will not interfere with the work; therefore the pond must be provided with the wooden hood and funnel E and F, which carry off the steam and discharge it into the atmosphere many feet above.

Having arrived at the end of the process as far as the retorting department is concerned, we will now take up the subject of refining—bearing in mind that the pro-

ducts from the retorts with which we have to deal are :—

Crude oil.

Semi-refined Air Condenser Naphtha.

Coke-Tower Naphtha.

Ammoniacal Water.

### REFINING.

#### *Distilling.*

It has been proposed to start refining operations by commencing with an acid and soda treatment in lieu of a distillation, but as that method of working results in a very much lower yield and no improvement in quality of the finished products,\* we will discard the idea, and start the refining of crude oil with a distillation.

The stills first used by the late James Young consisted of horizontal cast-iron cylinders with wrought-iron heads, and were about 3 feet 6 inches in diameter by 10 feet long, and the thickness of the metal was  $2\frac{1}{2}$  to 3 inches. They were soon found to be very costly, as they were never long in use before they cracked through the middle—circumferentially—and allowed their contents of 500 gallons to pour out into the furnace below.

The next stills adopted were upright cylinders made of boiler plate and having a concave bottom of the same metal. A, Fig. 29A, is a sectional illustration of one of these stills which was 6 feet 6 inches in diameter by

\* See Treatment *versus* Distillation, under heading "Laboratory."

6 feet high, and was charged with 1000 gallons of oil. It was found that the wrought-iron bottom was not capable of withstanding the heat of more than a few distillations, and after trying lining the furnace-side of the bottom with thin fire-bricks, the wrought-iron was replaced by convex cast-iron bottoms, as shown in B, Fig. 29A. These bottoms proved to be less useful than the wrought-iron ones, as four or five distillations resulted in the bottom cracking around the part marked X, and the whole bottom would sometimes drop, in one piece, into the furnace, and thus cause a serious fire.

The convex cast-iron bottoms were replaced by concave cast-iron ones, and the lower end of the wrought-iron body of the still was bevelled outwards (as shown in C, Fig. 29A), so as to be able to rivet it to the bottom without the use of angle iron. However the improvement that resulted did not altogether equal expectations, and finally a pot-shaped cast-iron still was adopted, and proved so satisfactory that this form of still has been in use ever since for distilling the heavier grades of oil.

Young distilled his lighter grades of oil in horizontal stills that had a parallelogram cross section, and were made of wrought iron, their dimensions being 12 feet long by 5 feet 8 inches broad and 6 feet deep, and the capacity was 2000 gallons.

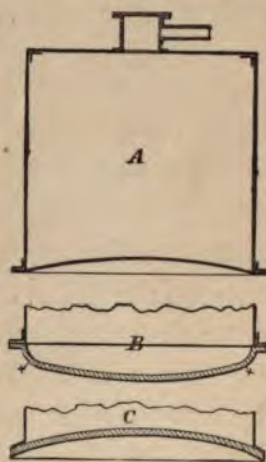

FIG. 29A.

The crude and heavy oil stills at the present day are, in some of the works, made entirely of cast iron, and are in two portions. The bottom portion is semi-spherical and the top is nearly so. Other works use the same pattern of castings, but interpose a ring of wrought iron about 18 to 24 inches wide, thus gaining a greater depth with a comparatively small increase in weight.

Perhaps the construction of crude and heavy oil still most commonly in use is that shown in Fig. 30. The wrought-iron portion B is bolted to the flange of the semi-spherical cast-iron portion A and the joint is made tight by the use of a mixture of sal-ammoniac and iron rust. The short casting C is riveted to the slightly dished top of the still, and the swan-neck D is bolted to the upper flange of this casting. The man-hole E is provided for the purpose of allowing a man to enter the still to clean it, &c. The heat that effects the distillation is supplied by the furnace F, and as it has been found that the direct play of the flames on the bottom of the still rapidly destroys the iron, a fire-brick arch G is constructed over the furnace to moderate the heat of the products of combustion before they pass through the pigeon-holes H into the chamber J surrounding the bottom of the still. The furnace draught is regulated by the damper K placed in the flue L leading to the chimney.

In the distillation of oil, as in the distillation of shale, it is necessary to remove the vapours from the still as soon as possible, and prevent them from condensing in the upper portion of the still and dropping

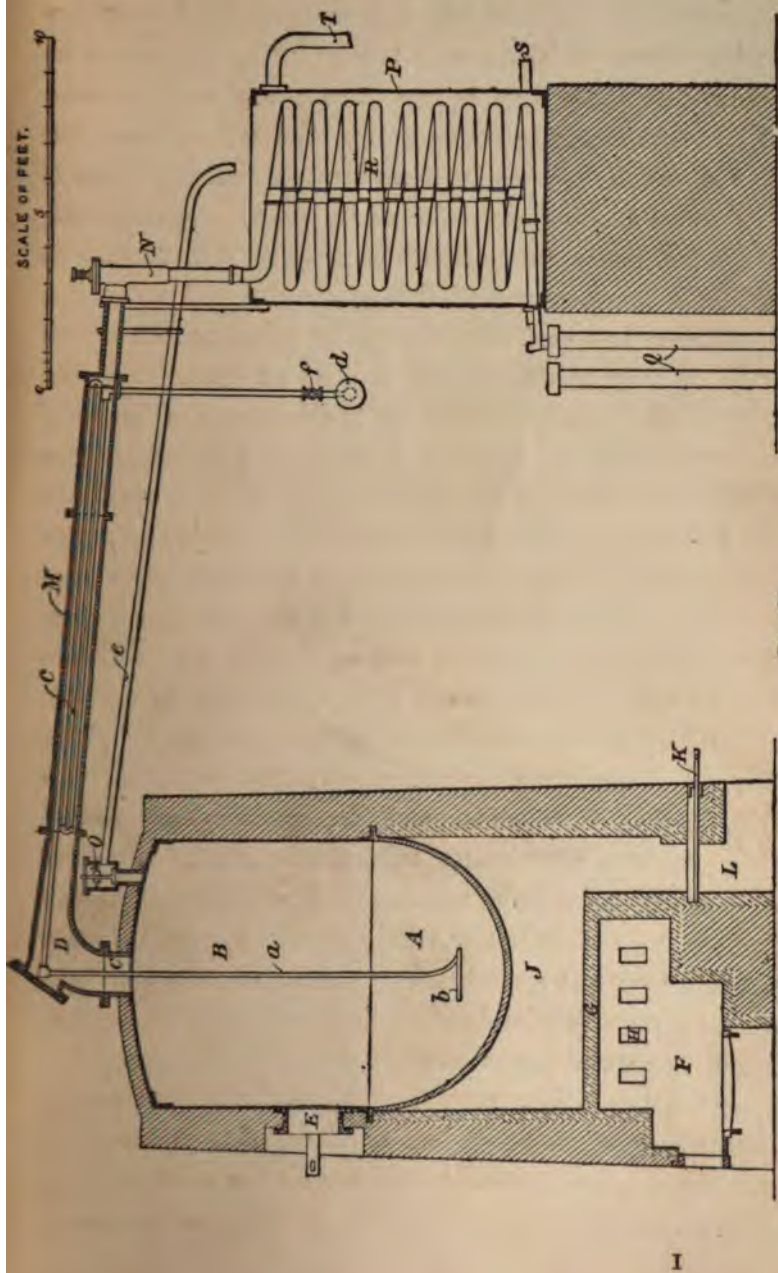

FIG. 30.

back into the boiling oil, and so being subjected to undue decomposition or "cracking." In order to accomplish these two points, steam under a pressure of 15 to 20 lbs. is introduced into the still through the pipe *a*, which finishes in a perforated circle *b*, about a foot above the bottom. As steam at a pressure of 15 to 20 lbs. has a temperature of only 250° to 259° F.—while the temperature of the oil in the still when the distillation has been in progress for three or four hours is about 300° to 400° F.—it is obvious that the steam must have a cooling effect on the contents of the still and necessitate an increase of fuel being burned in the furnace in order to counteract it. Various methods have been proposed or adopted for the purpose of overcoming this cooling effect, and some manufacturers pass the steam through a fire superheater (composed of a number of lengths of pipe coupled together by a manifold at each end, and built into a chamber heated by a furnace) before admitting it into the still. This method of superheating steam certainly does not save fuel, and, in fact, it increases the consumption if anything, as the superheater brickwork radiates considerable heat, and a large amount of heat passes from the furnace to the chimney, and, also, the steam in its passage from the superheater to the still loses a certain amount of its heat, no matter how well the pipe is insulated. Apart from the want of economy, this method of superheating is incorrect, from the fact that one superheater supplies eight or ten or more stills at one time, and as it is impracticable to have all the stills running a corresponding specific gravity distillate at the same

time, some of the stills must of necessity be receiving a steam that is either considerably hotter or colder than they require; that is, taking it for granted that it is possible to regulate the temperature of the superheated steam, and gradually increase it to suit the progress of the distillation, but this regulation is not practical in every-day work, and consequently fire superheaters often do more harm than good.

Mr. McCutcheon, of Young's Company, constructed the most practical and economical superheater, by making use of the oil vapours as a heating medium for the steam. He accomplishes the purpose by interposing an unusually large diameter connection M, Fig. 30, between the swan neck and the condenser connection N, and in the connection M building a coil *c*, of three lengths of 1-inch pipe, through which the steam has to pass in its passage from the main *d* to the perforated outlet *b*. In this way the steam is heated to the temperature of the oil vapours; and as the distillation progresses and the vapour temperature increases, the temperature of the steam is increased also, and thus a regular rise in temperature of the steam to suit the progress of the distillation is ensured.

The only other necessary apparatus connected with the distillation is the safety-valve O, condenser P and connections Q leading to the separator. The safety-valve is weighted so as to blow off at a pressure of 3 or 4 lbs., and in the event of the valve being raised, any oil vapours that pass through it are conducted by the pipe *e*, and allowed to impinge on the surface of the water contained in the condenser, and are thereby cooled



sufficiently to prevent them taking fire. The condenser is supplied with a cast-iron spiral coil or worm R (in which the vapours are condensed) and with the connections S and T, which are respectively the inlet and overflow for the condensing water.

As steam is used in the distillation it is obvious that the distillate leaving the condenser is mixed with water, and, consequently, separators (Figs. 19, 20 and 21) are placed between the connections Q and the receiving tanks for the different grades of oil. In future it will be taken for granted that the distillate passes through a separator in all cases where steam has been used in the distillation, and therefore, the separator will not be again referred to in this connection.

The crude oil that is charged into the still should be well settled and free from shale dust and other dirt, as well as water. If any dirt is present in the crude oil charged into a still it will settle down on the bottom of the still (after the oil has become well heated) and form a layer that is partially non-conducting, and which the heat from the furnace will have great difficulty in penetrating, and consequently will necessitate a very much hotter fire being used than if a crude oil free from dirt were charged into the still. If any water is present in the crude oil it may or may not make its presence known in time to prevent a "boil over." If the still is cautiously heated at the start the presence of water will make itself known as soon as the oil reaches a temperature of about 212° to 220° F. by causing a loud sizzling sound, and occasional thumps that can be plainly heard at a distance of 20 feet from the still.

The sizzling is due to the water that has been evaporated being condensed in the upper portion of the still and constantly dropping back into the hot oil; while the occasional thumps are due to quantities of water that might equal from one-eighth to one-half pint or more finding their way to the bottom of the still before they are converted into steam, thus raising a large volume of oil that drops back with a thump. Should a fierce fire be started under a still charged with crude oil that contained a little water, the warning sounds above mentioned would not be heard, but, instead, the water would be so quickly converted into steam, that the latter would form a frothing mixture with the oil, which would "boil over" into the condenser worm and cause endless mess and annoyance before it could be stopped by drawing the fires and allowing the still to cool down.

As mineral oils (taken as a generality) expand 0.4 per cent. for every rise in temperature of 10° F., it is evident that when a still is charged, ample room should be allowed for this expansion, and therefore, with the still shown in Fig. 30, an allowance of 18 inches is made for expansion, and head room for the vapours, or, in oil works phraseology, the still is charged 18 inches out.

From the foregoing it is plain that when a still is charged and ready for firing, it must be carefully and slowly heated at the start. After all noise has ceased and, therefore, all the water may be considered to have distilled off, the fire may be safely increased a little until the distillate begins to trickle from the condenser

worm ; and this being an intimation that the distillation has commenced, the steam valve *f* is gradually opened, so that at the end of about twenty minutes it is wide open and a full head of steam is blowing amongst the contents of the still. The stream of distillate, and the furnace fire then need the whole attention of the attendant, whose point in view should be to maintain a steady flow of distillate by so regulating the fire that the steam valve does not need to be touched from the time it is opened until it is shut again when the distillation is finished. Regulating the distillation by means of the fire necessitates far greater attention and more work than by the use of the steam, because, in the latter case, the attendant can put on a large amount of coal at a time and then sit down and watch the distillate, and if the stream increases, he simply closes the steam valve a little ; and then, as the coal becomes exhausted, and the distillate decreases in volume, he gradually opens up the steam valve again until he has it wide open, and then he replenishes the fire with another large supply of coal, and sits down again. If the steam valve is not allowed to be touched between the start and the finish of the distillation, the attendant has to "fire" more frequently, and with only a small quantity of fuel at a time, and consequently is not able to sit down as often as he might like to.

The distillate resulting from a distillation that has been regulated by the steam rather than by the fire, is decidedly inferior to a distillate resulting from a properly fired still ; it will have, perhaps, a slightly better colour and its specific gravity will be lower, owing to a certain

amount of "cracking" having taken place, but the yield will be very much lower and the distillate will contain less solid paraffins. Therefore it is a wise plan to place the steam valve at a height that cannot be reached without going to as much trouble as would be necessary in attending properly to the fire.

During the early part of the distillation the condenser must be kept well supplied with cold water so as to be sure that the more volatile products are thoroughly condensed and do not escape in the form of vapour; but as soon as the distillate begins to show signs of wax \* (when cooled to 40° F.) the water supply is diminished gradually until, when the distillate congeals at 50° F., the supply is entirely shut off and the water in the condenser is allowed to heat up until the distillation is finished. If the condenser were kept cool all the time, the heavier distillate containing wax would soon choke the condenser worm, and perhaps result in blowing up the still. Of course the safety valve would give a certain amount of relief, but as the valve is not designed to wholly relieve the still when the latter is running a normal stream of distillate, it would be necessary to at once close the steam valve and draw the fire in order to prevent an explosion, not to speak of stopping the waste that takes place when the oil vapours escape through the safety valve connection *e*.

The above remarks apply to nearly all the different distillations with which we shall have to deal, but the form of still is not the same for all the grades of oil. The still just described is only used when the distilla-

\* See "Laboratory."

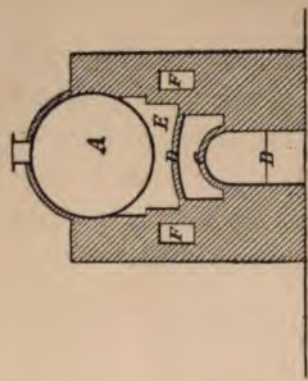
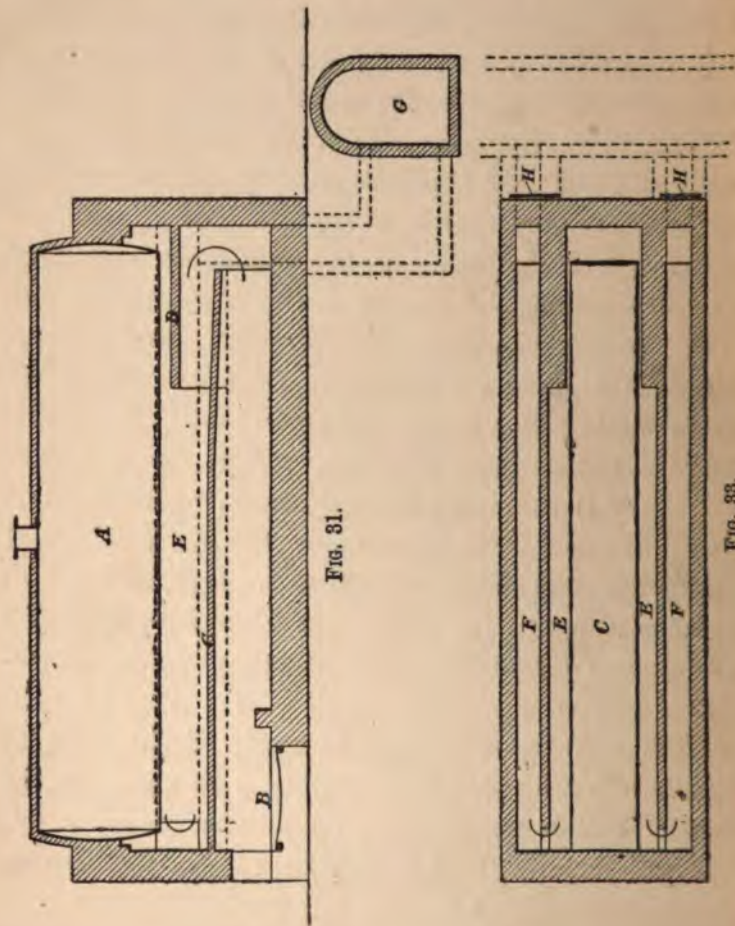

Scale of Feet.

0 1 2 3 4 5 6 7 8 9 10

FIG. 33.

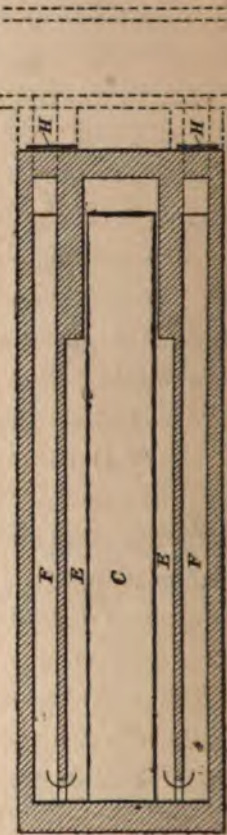

tion requires to be conducted to dryness or "coked." When the distillation is to be only partially performed (i.e. a liquid residuum is to be left in the still), a still constructed in the manner shown in Figs. 31, 32 and 33 is used. Referring to these figures, which are respectively a longitudinal elevation, end elevation and plan, A is the still set in brickwork and heated by the furnace B, placed at one end of the still. The products of combustion travel under the arch C to the further end of the furnace, and then upwards and between the arches C and D into the chamber E, where they come in direct contact with the lower quarter of the diameter of the still, and travelling towards the front end they branch off on either side and pass into the flues F, which conduct them to the back end again and down into the main flue G which leads to the chimney. The draught is regulated by the dampers H.

The condenser worms of these stills\* are usually continued into a brick building called a "Worm House." Such a house is illustrated in plan in Fig. 34, and Fig. 35 shows the end elevation in section. A are the continued condenser worms, and B are light sheet-iron troughs provided with a metal strap C at one end and a short spout at the other; the strap holds the trough close up to the pipes A, and at the same time allows the trough to be easily moved backwards and forwards along the pipe, so that its short spout can be placed in any one of the connections D that may be desired, thus allowing the distillate to be conducted to any of the receiving tanks to which the pipes E lead.

\* To be hereafter known as "Burning Oil Still."

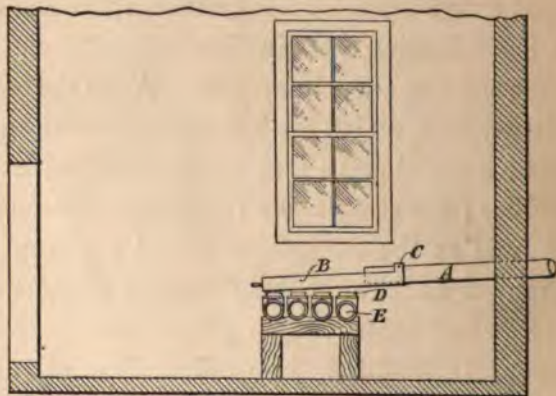
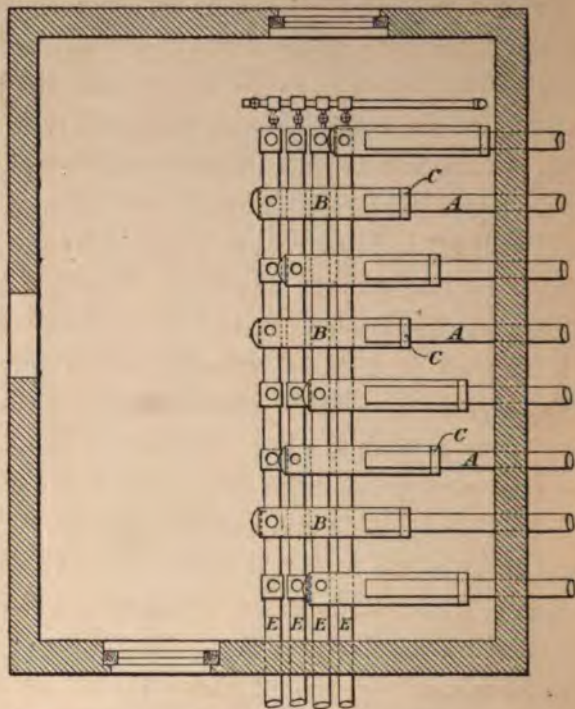

Scale of Feet.

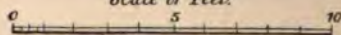

Figs. 34 and 35.

That the various grades of oil may be more easily followed from start to finish of the refining process, the capacities, life, &c., of the various stills, together with the fuel and steam used, and also the amount of condensing surface needed, &c., will be dealt with later under the heading "Distilling Data."

*Crude Oil.*—Generally speaking crude oil has a greenish-black colour, a smell peculiar to itself (that cannot be properly described) and solidifies\* at about 80° F., and at ordinary temperatures (50° to 60°) its consistency is about that of soft butter.

TABLE XIX.

Seam of Shale.	Specific Gravity of Crude Oil.			
	Horizontal Retort.	Vertical Retort.	Henderson Retort.	Young and Beilby Retort.
Addiewell (thick) .	865	889	878	
"    (Dam) .	..	883	875	
Broxburn Oil Co.'s .	..	..	867	
Charlesfield . .	..	880	870	876
Cobbinshaw . .	865	..	880	
Fortneuk . . .	..	887	863	878
Grey shale . . .	..	872	865	
Methyl . . . .	871	915	..	
Newliston . . .	..	873	866	875
Oakbank Oil Co.'s .	846	883	..	

As is natural to suppose, crude oils vary considerably in specific gravity according to the shale from

\* See "Laboratory," p. 214.



which they are produced and the form of retorts in which shales are distilled. As will be seen from Table XIX., the horizontal retorts yielded the lightest, and the old form of vertical the heaviest crude oil.

When a crude oil is distilled it yields—

Once-run distillate.

Chrysene.

Coke.

Gas.

The once-run distillate, which averages 93 to 95 per cent. of the crude oil charged into the still, will be more particularly referred to later, but for the present we will dispose of it by pumping it to its storage tank.

Chrysene, or still ends, is the highest boiling point portion of the crude oil, and consequently only distills over at the end of the distillation. It is a dark greenish-red coloured fluid when hot, but when cooled to about 40° F. it is of a yellowish colour and more or less brittle. A piece of the cooled chrysene after being held in the hand for a few minutes becomes plastic and sticky, and cannot be easily removed from the skin, and therefore it is an objectionable substance for either lubricating oil or wax to contain, and consequently it is separated by fractionation at the still. The yield of chrysene amounts to, on an average, 0·6 per cent., and, as no better use has been found for it, it is mixed with coal dust and burned as fuel under the stills, &c. This substance is further referred to under the heading "Laboratory."

The coke resulting from the distillation of crude oil is somewhat softer or less brittle than gas-house coke.

It varies in thickness from 2 to 3 feet, and is formed as a solid mass on the bottom and partly on the side of the cast-iron portion of the still (Fig. 30). It is usually very close grained on the under side (i.e. the side next the iron), but gradually gets less dense until, near the surface, it is spongy in appearance. It has a dead black colour except on the very surface, which latter is a glossy black. It is used principally under the stills as fuel, but is also used in the manufacture of electric light carbons. The yield of coke varies \* from 27 to 30 lbs. per 100 gallons of crude oil.

The gas is generally a wasted product, but one of the companies collects it and uses it as fuel. The quantity of gas resulting from the distillation of 2000 gallons of crude amounts to about 1000 cubic feet, and it seems incredible that arrangements are not more generally made for its collection and use. The whole of the 1000 cubic feet is not permanent gas, but about 10 per cent. of the volume is light oil vapours that are not condensed in their passage through the condenser.

As the various grades of oil receive acid and soda treatments between distillations, we will, before proceeding further with the routine of manufacture, take up the subject of, and review the apparatus used in,

#### TREATING.

Some of the companies preferred to treat oil by first using caustic soda, then acid, and finally a wash with sufficient weak solution of soda to neutralise any acid

\* See "Distilling Data."

that might be left in the oil. The reason for this method of procedure is not at all plain, and, as it does not result in any improvement in the quality of the oil, but necessitates an additional pumping and, consequently, additional cost, the only apparent reason for its adoption is a desire on the part of its adopters to be different from other people.

The treatment of an oil should be started with acid, and it is accomplished by violently agitating the mixture of oil and acid in a tank or agitator.

The old style of agitator was a cast-iron vat 8 feet or so in diameter by 4 to 5 feet deep, and, if used for the "acid" treatment, it was lined with sheet lead; if for the soda treatment, the lead lining was dispensed with. The agitation in former days was performed by means of blades or vanes attached either horizontally to a vertical shaft, or vertically to a horizontal arm, and made to revolve rapidly through the contents of the agitator. The results obtained in this way were not satisfactory on account of the inability of the machinery to produce a sufficiently intimate mixture between the oil and acid, but this method of agitation is still in use in some of the works for the "soda" treatment.

Very commonly, the agitation for both the acid and the soda treatments is performed now by means of air, and more rarely by the use of centrifugal stirrers. In the former case the agitator should be of greater depth than diameter, and the sizes usually adopted are from 6 to 9 feet in diameter, by 10 to 15 feet deep, and having a capacity of only 1500 to 5000 gallons. The air is conducted to the bottom of the agitator through

a 2-inch pipe, and, being under a pressure of 6 to 10 lbs. per square inch, it tosses the mixture of oil and acid about in its passage to the surface. When the centrifugal stirrer is used, the agitator is usually greater in diameter than height, and only holds about 1200 gallons. The centrifugal stirrer is very similar in construction to

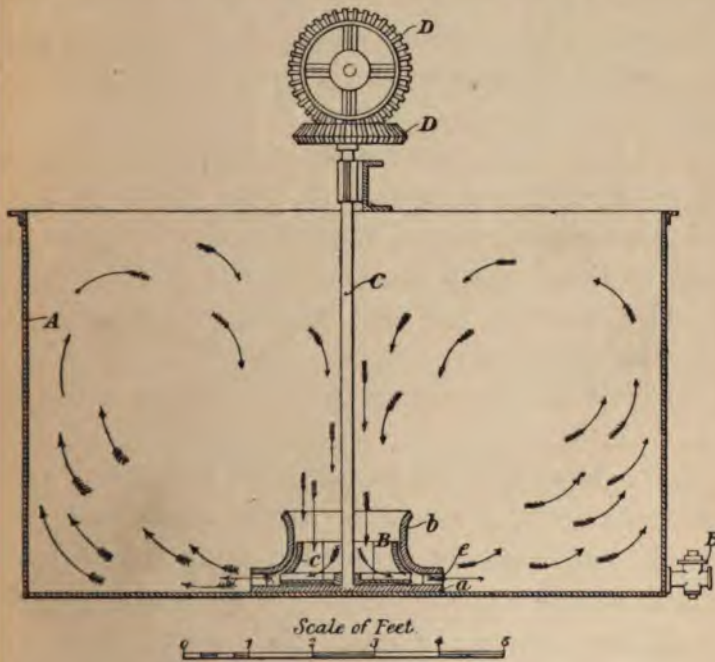

FIG. 36.

a turbine, and is shown in section in Fig. 36, in which A is the agitator, and B the stirrer. The portion *a* of the stirrer is bolted firmly to the bottom of the agitator, and *b* is bolted to *a*, while *c* is securely fastened to the shaft C, and rapidly revolved by the gears D. The oil is sucked down through the centre of the stirrer and

violently discharged, through the passages *e*, against the side of the tank. In this way the oil and acid are most thoroughly mixed, and the completeness of the mixing, as compared with air agitation, can be easily seen by dipping pieces of paper into the agitating oils and then holding them up to the light, when the paper from the air agitation will show specks of tar that are comparatively large and far apart, while the centrifugal stirrer paper will show a mass of finely divided particles of tar.

This test shows that the centrifugal stirrer causes a more thorough and intimate mixture of the oil and acid than the air does, and working results also point in that direction, because considerably less acid is needed (in order to secure the same results) with centrifugal than with air agitation.

The method of procedure in the treatment of oils is as follows :—

After the agitator has been charged with the oil and agitation started, the acid is slowly added, and the agitation continued for a period varying from fifteen minutes to an hour (according to the grade of oil) after the oil has received the whole of its acid. After the prescribed length of time for agitation has elapsed, the mixture is allowed to remain at rest for a period varying from two to twelve or eighteen hours, at the end of which time the tar has all settled to the bottom. This "acid tar" is now drawn off through the cock *E* (Fig. 36) and is run to a receiving tank, and will be referred to again under "Acid Tar." The clear dark-coloured oil is then pumped from the acid agitator into



storage tank, while the other is connected with the air compressor or "blower." As soon as the egg is subjected to the requisite pressure, the acid is forced up the pipe that continues to the bottom of the egg, and is discharged into the agitated oil above referred to.

The Author was greatly surprised at the smallness of the quantity of oil treated at a time, and when he asked a foreman the reason for it, he was informed that "if a batch of oil did not turn out all right, only a small quantity was spoilt, but if the size of the agitators were increased the quantity of oil that might be spoilt would be correspondingly increased." That is, indeed, a very poor reason, and simply points to incapability on the part of the foreman to turn out uniformly good work. If the foreman is a capable man there is no reason why he cannot form a correct estimate of the quality of each batch of oil before it is treated, and how much acid it should receive; and, in that case, the treatment of 40,000 to 50,000 gallon batches of oil can be just as well conducted as 1500 to 5000 gallon batches, and will result in an all-round saving—less acid will be required, less oil will have to be recovered, there will be fewer agitators to clean, less machinery to look after and keep in repair; no greater length of time is required to agitate a batch of 50,000 gallons than a batch of 1000 gallons, and consequently, the same amount of work can be done in one large batch with the aid of very much less labour than in the case of numerous small batches.

Under the heading of Treating Data will be found

statistics relating to the amount of acid and acid tar left in the settled "acid oils," which will be of value and interest.

### *Once-Run Oil.*

The once-run oil from the crude oil distillation (which we left in its storage tank), after being settled perfectly free from all moisture, is now pumped into an "acid" agitator, and its temperature should not be over 15 to 20 degrees higher than its setting point\* when agitation is started. This oil may be advantageously treated with the acid tars from the light oil treatments, or with recovered acid of 77° Twaddell followed by a treatment with 148° Tw. acid. If the "acid tars" are used, 10 per cent. by volume should be slowly discharged from the egg into the agitating oil, and after the latter has received all its acid the agitation is continued for fifty minutes; or, the acid may be added in two or three successive portions, the agitation being continued for thirty minutes and then the oil allowed to settle for fifteen minutes, and the settled tar drawn off before the next portion is added. If recovered acid is used, 10 per cent. or less (according to the quality of the distillate) is added in one or more portions and agitated and settled as above; but, after all the weak acid has been added and the resulting tar withdrawn, it is necessary to give the oil a further treatment with  $\frac{1}{2}$  to 1 per cent. of 148° Tw. acid. If the use of only fresh acid is preferred, the strength should not exceed 148° Tw., and the amount required will be from 4 to 5 per cent.

\* See "Laboratory"



Whether acid tars, recovered acid, or only fresh acid is used, it is necessary, after the last stirring, to allow the oil to settle for sixteen to twenty hours, after which the resulting tar is carefully drained off before the clear oil is transferred to the soda agitator.

In the soda agitator this oil should first be treated with the soda tars from the second and third stage treatments, and, after being agitated for thirty minutes and allowed to settle for twenty minutes and the tar drawn off, a further treatment with 1 per cent. of 65° Tw., recovered soda \* solution is given. The oil should be agitated for one hour after the second addition of soda, and must then be allowed to settle for eight hours, after which the clear oil is to be pumped to the storage tank for

#### *Treated Once-Run Oil.*

This oil is next distilled in the

*First Stage Oil Stills.* †—The distillation is conducted with the aid of steam, and the distillate should be fractionated from the start up to a specific gravity of 770 at the worm end for naphtha; from 770 up to 835 for "light oil" distillate, and from 835 to 850 for heavy oil distillate, while from 850 up to about 870 constitutes "heavy oil and wax" distillate. When the specific gravity of 870 is reached, the fire should be drawn from under the still, and the residue left in the still pumped to the first stage residuum storage tank. We therefore see that the separations made at the first stage oil stills are:—

\* See "Soda Recovery."

† See Figs. 31 and 32.

Naphtha . . . . .	(to be referred to later).
First stage light oil distillate.	
,, heavy oil distillate.	
Heavy oil and wax . . . .	(to be referred to later).
First stage residuum. . . .	"    "

The light and heavy oil distillates are pumped from their respective storage tanks into separate agitators, where they receive respectively  $1\frac{1}{4}$  and  $1\frac{1}{2}$  per cent. of  $170^{\circ}$  Tw. acid. The agitation in both cases should be continued for from thirty to forty-five minutes, and the temperature of the oil should not be above  $70^{\circ}$  and  $80^{\circ}$  F. After the agitation is completed, the oils are allowed to settle for about sixteen hours, or, if  $\frac{1}{50}$  of 1 per cent. of water is thrown into the agitator a couple of minutes before the agitation is completed, the oils need be settled only three or four hours before being transferred to the soda agitator.

The soda treatment at this stage should be accomplished with the use of recovered soda of  $60^{\circ}$  to  $65^{\circ}$  Tw.—the light distillate receiving about 0.6 per cent., and the heavy distillate about 0.75 per cent. About ten to twelve hours are necessary to effect the thorough settlement of the soda tars, and after the tars have been withdrawn, the oils are pumped to, and mixed in, the storage tank that supplies the

*Second Stage Oil Stills.*—These stills are similar in construction and setting to the first stage stills, but they are run with a "feed," that is, after the distillation has started, the first stage treated oil is allowed to run from the elevated storage tank into the still and the volume

of inflowing oil is regulated so as to equal the volume of oil leaving the still in the form of vapour, and thus a steady level of oil is maintained in the still. To ensure the volume of inflowing oil being equal to the outgoing distillate, the still is fitted on the front or furnace end, with gauge cocks, which the attendant opens every now and again in order to locate the oil level in the still.

So that the ingoing oil may not have an undue cooling effect on the contents of the still, the Author would advise the construction of a coil in an enlarged connection between the still and the condenser, through which the oil should be made to flow before being liberated at a point near the bottom of the still.

As soon as the distillation commences, steam is turned into the still and the distillate from the start (i.e. about 770 specific gravity) up to a specific gravity of 835 at the worm end is run to the second stage light oil tank, and as soon as \* that specific gravity is reached, the "feed" is shut off and the distillation continued until the distillate reaches 850 specific gravity at the worm end, when the steam is shut off and the fire drawn. This second fraction—from 835 to 850—is run to the second stage heavy oil tank, while the residuum left in the still is pumped to the second and third stage residuum tank.

From the above distillation is obtained :—

Second stage light oil distillate.

„ heavy „  
 „ residuum „ (to be referred to later).

\* See "Distilling Data."

The second stage light and heavy distillates are treated separately with from 0·35 per cent. to 0·375 per cent., and 0·4 per cent. to 0·55 per cent. of 170° Tw. acid respectively. The soda treatment should consist of 0·5 per cent. and 0·6 per cent. of 64° Tw. caustic soda solution, made from fresh "drum" caustic soda, and not recovered soda. The length of time of agitation and settling, &c., should be the same as in the case of the first stage oils.

The treated second stage light and heavy oils are stored in separate tanks to await another distillation.

*Third Stage "Light" Oil Stills.*—These stills are like the second stage ones, and are run with the aid of steam, and the second stage treated light oil is "fed." The specific gravities at which the distillate is fractionated depend upon the number of grades and quality of burning oil required. If only one grade of burning oil were wanted, the distillate would be run from the start, until the worm end specific gravity reached, say, 840 to 845, and this would give a bulk specific gravity of about 812. If two grades of burning oil were desired—a good and somewhat inferior one—the lighter distillate at the start of the distillation should be allowed to run into what we will call No. 2 tank; this distillate (which will start with a worm end specific gravity of about 770) should be run until its worm end specific gravity reaches 790. At that specific gravity the distillate stream should be turned into another tank (which we will designate No. 1), and when the "bulk"\* specific gravity of the contents of this No. 1 tank reaches

\* That is, the whole of the contents of the tank well mixed.

810 the stream should be turned back into No. 2 tank, into which it is allowed to run until the worm end specific gravity reaches 840 to 845. The bulk specific gravity of No. 2 tank will then be about 804 to 810.

As an oil that has a specific gravity of over 840 is unsuitable for burning in lamps, the feed to the still is shut off when that specific gravity is reached,\* but the distillation is continued until the worm end specific gravity of the distillate reaches 850, and then the steam is shut off and the fire drawn. The distillate that runs between the specific gravities of 840 and 850 constitutes intermediate oil.

The third stage light oil stills therefore yield :—

† No. 1 grade burning oil (ready for the market).

† No. 2           "           "           "           "

Intermediate oil (ready for the market and for gas making, &c.).

Third stage light residuum (to be referred to later).

*Third Stage "Heavy" Oil Stills.*—These are run without a feed, but with the aid of steam. The treated second stage heavy oil charged into these stills should be so fractionated that the fractions correspond in bulk specific gravity with those obtained from the third stage "light" oil stills with which they are mixed. When the distillate from the third stage "heavy" oil stills reaches 850 specific gravity at the worm end, the distillation is stopped and the fractions obtained from these stills will most probably be :—

\* See "Distilling Data."

† "See Laboratory."

No. 2 grade burning oil (mixed with same from third stage light oil stills).

Intermediate oil (ditto).

Third stage heavy residuum (to be referred to later).

The burning and intermediate oils from the last two distillations must, of course, be thoroughly settled and free from moisture before being pumped to their storage tanks, ready for barrelling and delivery in the market.

Some of the companies make a speciality of a burning oil that has been finished with a treatment instead of a distillation. In that case an oil like No. 1 grade burning oil is usually chosen, and this is treated with 2 to 2½ per cent. of 170° Tw. acid with ten to fifteen minutes' agitation. After the acid tar has been allowed fifteen to twenty minutes to settle out, and has been drawn off, the oil is transferred to the soda agitator, where it is first agitated for two or three minutes with 5 per cent. of water, settled for five minutes, and then, after the water has been drawn off, ½ per cent. of 3° Tw. caustic soda solution is added and agitated sufficiently to ensure all the acid (that may be left in the oil) being neutralised. The weak soda solution having been settled out and run off, a further treatment of ¼ per cent. of 65° Tw. soda is given the oil, and after three or four minutes' agitation the contents of the agitator must be allowed to remain quiet for about an hour, after which the oil is transferred to shallow tanks and allowed to settle for fifteen to eighteen hours, at the end of which time it should be perfectly bright and ready for the market.

The Lighthouse Commissioners are exceedingly particular in regard to the quality of the oil used in lighthouses, and place restrictions on the properties of the oil that necessitate a special fractionation being made at the stills. As the flash point must not be under  $130^{\circ}$  F., and, when the oil is subjected to distillation, a residue of not more than 7 per cent. is allowed to remain in the still when the distillation is stopped at a temperature  $572^{\circ}$  F., it is necessary to cut out all light oils and not use any heavy oils that have a boiling point of over  $590^{\circ}$  F. in the manufacture of this oil. Usually the oil is obtained from the third stage light oil stills by running them under "feed" for the usual\* length of time, and then, after filling up the stills to the highest gauge cock, the feed is shut off, and when the worm end specific gravity reaches 792 the distillate from that point, and until the "bulk" specific gravity reaches 814, is run to the lighthouse oil tank. This cut gives an oil that has a specific gravity of 814, flash point of  $145^{\circ}$ , and leaves a residue of about 5 per cent. in the still after the temperature of the vapours has reached  $590^{\circ}$  F.

A very good burning oil for use on ships, &c., can be obtained from the lubricating oil stills (to be referred to), by cutting out the distillate between the specific gravities of 825 and 848; treating this fraction with 2 per cent.  $170^{\circ}$  Tw. acid, and 2 per cent. of  $10^{\circ}$  Tw. soda, and then distilling it off soda† and cutting out the fraction that runs between the worm end specific gravities of 825 to 846 to 848. This gives a burning

\* See "Distilling Data."

† See "Soda Distillation."

oil that is specially safe for marine purposes, as it has a flash point of 225° F.

*Fourth Stage Stills.*—The second and third stage light and heavy residuums are mixed together and distilled in a still like Figs. 31 to 33. The distillate from the start until the worm end specific gravity reaches 870 constitutes heavy oil and wax, and when that specific gravity is reached the distillation is stopped. The yield from these stills is therefore :—

Fourth stage heavy oil and wax (to be referred to later).

Fourth stage residuum.

*Heavy Residuum Stills.*—These are similar to Fig. 30, and are charged with the mixed residuum from the first and fourth stage oil stills, and about 10 lbs. of solid caustic soda per 100 gallons of oil. Steam is used in the distillation, and the distillate is fractionated as follows :—

From the start until the colour begins to get dark constitutes heavy oil and wax, from the starting of the dark colour until chrysene commences to distil over, goes for once-run oil equivalent, and, as the still bottom is by that time red-hot, the fire is drawn and the separations obtained will be :—

Residuum stills heavy oil and wax (to be referred to later).

Once-run oil equivalent (pumped to the once-run oil tank).

Chrysene (mixed with coal dust and burnt).

Soda coke.\*

\* See "Soda Recovery."



*Heavy Oils and Wax.*

The mixed heavy oils and wax from the first and fourth stage oil stills and the residuum still are mixed and cooled \* to a temperature of about 80° F., and then pumped into filter presses † until the pressure reaches about 60 lbs. per square inch. The presses are then opened and their contents removed and placed in canvas sheets and then in a hydraulic press ‡ and subjected to a pressure of 550 lbs. per square inch of the cake of wax. The wax left in the sheets after being hydraulic pressed is known as Hard Crude Scale, and is ready for the market as such. The squeezings from the filter and hydraulic presses are mixed and cooled to about 40° F., and then filter pressed and finally hydraulic pressed. The wax from these second hydraulic presses is known as Intermediate Crude Scale; the squeezings are mixed with the squeezings from the first filter and hydraulic pressing. The squeezings from the second filter presses are cooled to 30° F., and then again filter pressed, and the resulting oil is pumped to the "Pressed Oil" storage tank. The wax that is left in the third set of filter presses is next hydraulic pressed, and the resulting wax constitutes Soft Crude Scale.

From the pressing of the heavy oils and wax there is, therefore, obtained :—

Hard crude scale	(128° F. melting point)	} To be referred to later.
Intermediate do.	(120° " " " )	
Soft do.	(112° " " " )	
Pressed oil.		

\* See "Pressing."

† See Figs. 46, 47, 48.

‡ See Fig. 45.

The pressed oil is next treated with 2 to  $2\frac{1}{2}$  per cent. of  $148^{\circ}$  Tw. acid, and after fifteen to twenty minutes' agitation and as many minutes' settling, the tar is drawn off and the oil is then further treated with 2 per cent. of  $170^{\circ}$  Tw. acid. The second agitation should be continued for at least thirty minutes, and then allowed to thoroughly settle before being transferred to the soda agitator, where it receives 1 per cent. of  $60^{\circ}$  Tw. soda.

### *Soda Distillation.*

The treated pressed oil is now distilled in stills similar to Fig. 30, into which stills are placed 17 lbs. of solid caustic soda per 100 gallons of oil. Steam is used in this distillation, and the distillate from the start until the worm end specific gravity reaches  $\cdot 860$  is pumped to the second stage heavy oil storage tank, and the rest of the distillate is fractionated so as to give various grades of lubricating oils. For instance, if  $875$  and  $890$  specific gravity finished oils were required, the fractionation would be made as follows :—

From 860 up to 880 specific gravities	}	= 875 oil.
at worm end . . . . .		
From 880 up to 910 to 912 specific gravities at worm end . . . . .	}	= 890 oil.

The distillation is run to dryness, and after the distillate reaches the specific gravity of  $912$  the colour is very dark, and the small amount that follows is mixed with coal dust and burnt.

This distillation yields:—

875 lubricating oil distillate.

890       "       "       "

Chrysene.

Soda coke.\*

The 875 and 890 distillates whose actual specific gravities are 873 and 880 are now cooled to about 20° F., and filter and hydraulic pressed. The squeezings are known as pressed lubricating oil distillates, and the waxes resulting from the pressings, which have low melting points—95° to 105°—we will call lubricating oil waxes.

The pressed lubricating oil distillates have low flash points, and in order to raise the latter the distillates used to be run into a steaming still, and steam under a pressure of 35 lbs. was allowed to blow through the oils for eighteen to twenty hours. The raising of the flash point is now usually accomplished by running the oils through stills similar to the Coffey still, used for extracting the ammonia from ammonia water. †

The steamed distillates, after being cooled to about 70° F., are treated with 3 per cent. and 5 per cent. respectively of 170° Tw. acid, and finally with 1 per cent. of 2° Tw. caustic soda, and are then allowed to settle at a temperature of about 100° F. for four or five days in shallow tanks covered by glass roofs and known as bleachers. The sun passing through the glass roof has a decided bleaching effect on the oils, and at the end of a week or so the oils are ready for the market as lubricating oils of 875 and 890 specific gravity.

\* See "Soda Recovery."

† See Fig. 50.

*Naphtha.*

The semi-refined naphtha from the "air-condenser naphtha" is mixed with the naphtha from the first stage oil stills, and then treated with 3 per cent. of 170° Tw. acid, and finally with  $\frac{1}{4}$  per cent. of 64° Tw. soda. The treated naphtha is charged into steam jacketed stills, and distilled with the aid of open steam. From the start (about 690 specific gravity) until the specific gravity of the distillate stream reaches 760, constitutes commercial naphtha, but, of course, this can be otherwise fractionated to suit requirements. When the specific gravity at the worm end reaches 760, both the open and jacket steam should be shut off, and the residuum left in the still pumped to the once-run oil storage tank.

*Coke-Tower Naphtha.*

The purification of this product is effected by first giving it a treatment with  $1\frac{1}{2}$  to 2 per cent. of 170° Tw. acid, followed by  $\frac{1}{2}$  to 1 per cent. of 64° Tw. caustic soda. The treated oil is then charged into the distilling apparatus shown in Fig. 38, and known as the "Gasoline" still. Referring to Fig. 38, A is the still proper, the contents of which are heated by the steam coil B, the vapours generated in A passing up through the fractionating column C, and over into the condenser D. Owing to the very volatile nature of the distillate, it is of the greatest importance that it should not be allowed to come in contact with the air in its passage from the still to the storage tank, and, there-

fore, the worm end E is fitted with the vapour trap F. This trap is made of cast iron and provided on the top with an opening G (to allow of ready access to the inside) closed by the cover H and made vapour tight by the lute I. The front of the trap is recessed to receive the thick plate of glass J, which is held in its

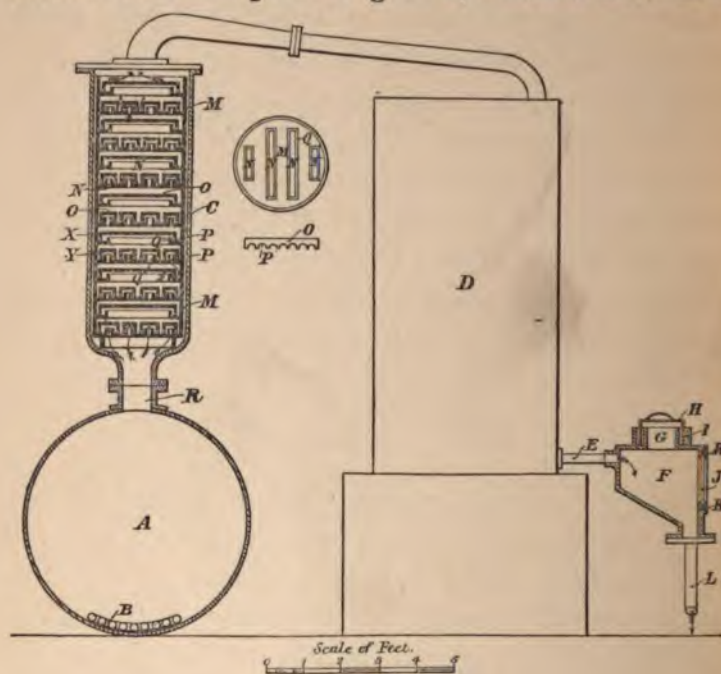

FIG. 38.

place by the iron strips K, and the joint made tight by the use of red-lead putty. The object of the glass front is to enable the attendant to see the flow of distillate and thus judge how the distillation is progressing. The distillate runs through the connection L into the receiving tank, and this latter tank must have a perfectly tight cover, and be fitted with one or more

water-luted manholes to allow of the escape of vapours in case the latter may be generated by the heat of the sun, &c. Such generation of vapour may be greatly minimised by sinking the tank in the ground, so that the latter is just level with the top of the tank.

Referring again to the fractionating column C. This is filled with the cast-iron dishes M, which are constructed with the openings N, the upper side of which openings are provided with covers O. The bottom of the covers O are provided with the semicircular notches P. In placing the dishes in the column it is better to place them so that the openings N are at right angles to the openings in the dish below, as at X and Y.

When the distillation starts, the heavier vapours condense and fill up the dishes to the height of the raised sides Q of the openings N; and the vapours that follow on from the still, in order to escape through the notches P, have to bubble through a depth of one inch of the condensed vapours lying in the dishes. In this way nothing but the very lightest of the vapours can find their way to the condenser worm end; a very perfect separation or fractionation is thus obtained. Years ago it was customary to use only ordinary connections between the still and condenser, and, consequently, more or less heavy vapours passed over with the light ones; when the column was adopted it was found that the still ran a very much longer time before the required bulk specific gravity of the distillate was obtained, and that the yield was increased about 10 per cent.

The distillate from the gasoline still is run from the start until the bulk specific gravity reaches 661 for

commercial gasoline, and then the distillate is turned into another tank until the bulk specific gravity reaches 700, when the distillation is stopped and the residue left in the still should be pumped to the treated once-run oil storage tank. The second fraction (that has the bulk specific gravity of 700) ought to be put back in the still and redistilled, as it will then yield one or two per cent. more gasoline, and the rest of the distillate will be fit for the market as refined naphtha.

The connection R on the still should be provided with a side outlet leading to the condenser worm, because a bulk specific gravity of 700 cannot be reached if the vapours have to pass up through the column—the steam coil not being designed to supply sufficient heat to the vapours (when the latter get heavy)—to carry them up through the oil-luted dishes M.

#### PRESSING.

In order to extract the wax from the oil the mixture is subjected to pressure, but before that can be done it is necessary that the mixture be first cooled. The method adopted for cooling the mixture depends largely upon what cold test is desired.

As the first pressing is usually made at a temperature of about 70° to 80° F., the cooling is effected in many cases by allowing the heavy oils and wax to stand in a large shallow iron tank exposed to the atmosphere and stirred every few hours by long handled wooden scrapers. This is an expensive way of doing the work as it necessitates the use of considerable manual labour.

The lower cold test oils (i.e. oils less rich in wax)

have to be cooled lower than can be done by exposing them, in the summer time, to the atmosphere, and therefore artificial means of cooling have to be resorted to.

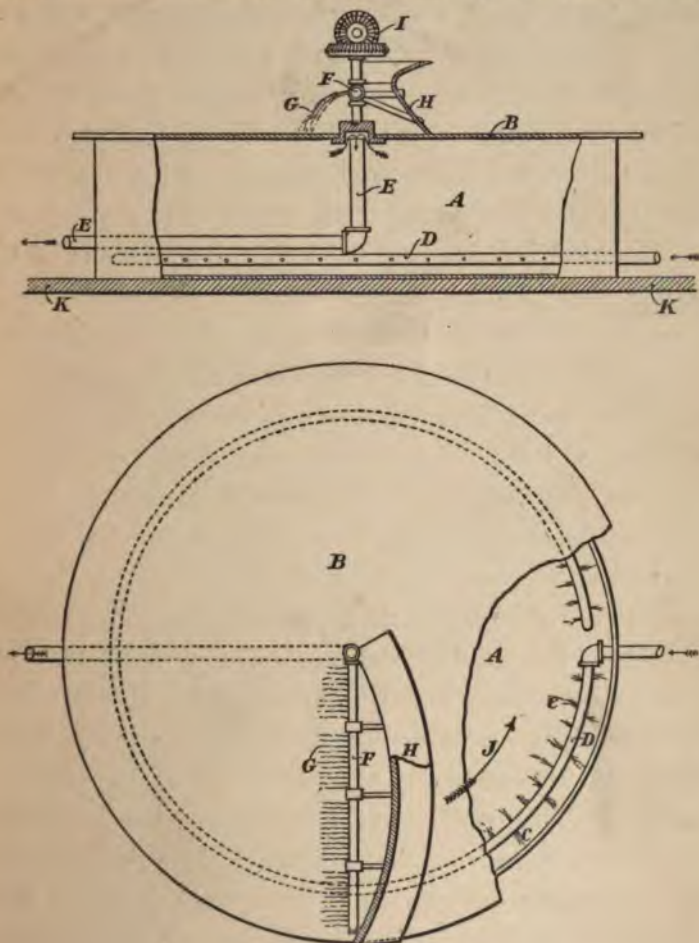

FIGS. 39 and 40.

The first artificial cooler that was used was designed by the late James Young, and called by him "The Drum," and is illustrated in Figs. 39 and 40. It consisted of a



shallow iron tank A, provided with a water-tight cover B, which projected a few inches all round; cold water was admitted near the bottom of the tank in jets C, from the circle of pipe D, and overflowed through the pipe E. The oil to be cooled was run through the pipe F, and allowed to fall in small streams G upon the surface of the cover B, and on the other side of the pipe from which the oil was discharged was secured a scraper H. The pipe and its scraper were kept slowly revolving in the direction indicated by the arrow J, by means of the gears I, and as the scraper removed the solidified oil from the surface of B, the streams of oil flowing from the pipe F distributed a fresh layer of oil, which went on cooling until the revolving scraper came round again and removed it. The convexity of the scraper (in the direction in which the latter travelled) resulted in the solidified oil being pushed over the edge of the cover B and falling on the brick floor K, whence it was shovelled into bags and then pressed.

When the trade demanded a low cold test oil, Young's cooler was found to be incapable of giving the desired results, and a cooler constructed on the principle of Fig. 41, and known as the "cylinder" cooler, was next designed. This cooler consisted of the cast-iron cylinder A and steel cylinder B, both of which were firmly bolted to the cast-iron ends C, which latter were provided with stuffing boxes D and fitted with glands. The cylinder was mounted on the iron frame E and rotated by gears that engaged in the cogs F. The lower part of the cylinder dipped into the saucer (G) containing the oil to be cooled, and cold brine was kept constantly

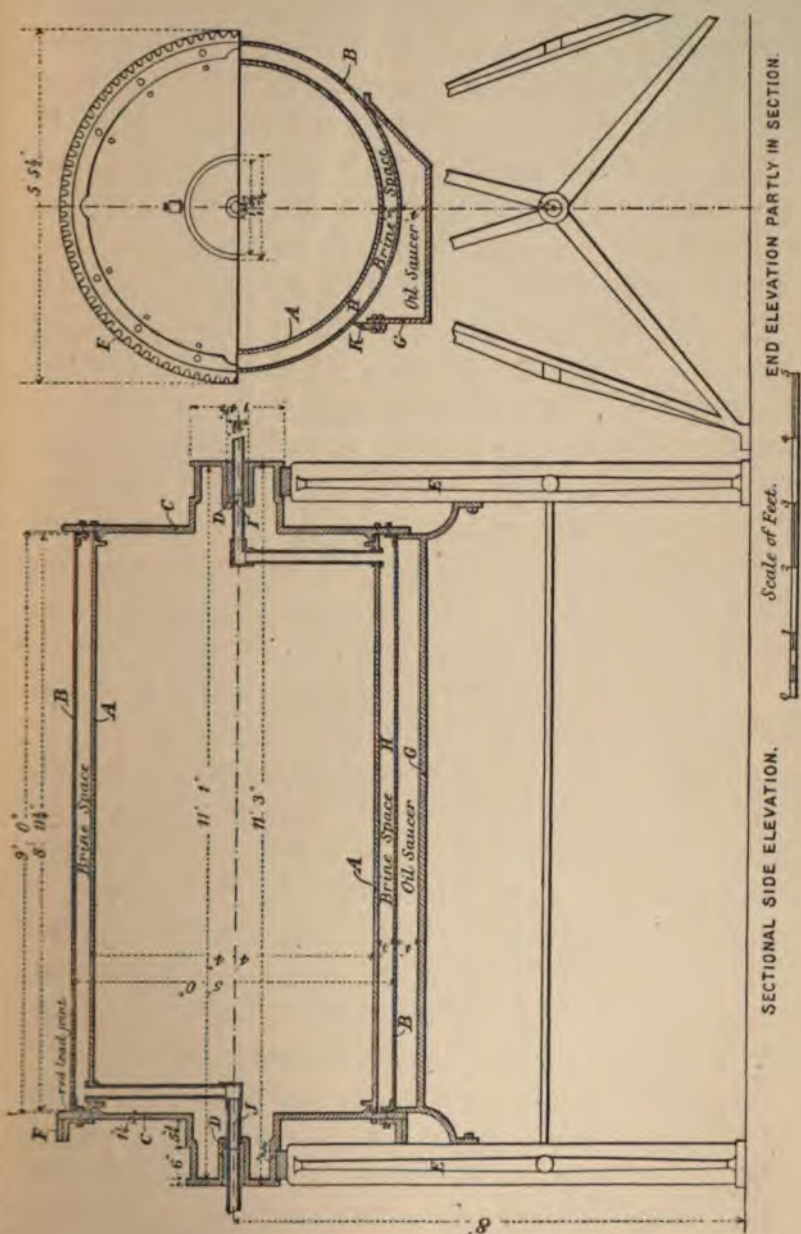

FIG. 41.

circulating through the annular space H by means of the inlet I and outlet J.

As the cylinder slowly revolved its outside was coated with a thin film of the oil (contained in the saucer G), which the cold brine (contained in the annular space H) quickly congealed, and by the time it reached the knife K it was cooled down to the temperature of the brine, and, being detached by the knife, it dropped into a trough, from which it was sucked by a pump and discharged into the presses. Although this cylinder required very little attention, cooled the oil to practically any desired temperature, and was in every way a marked improvement over Young's "drum," yet it did not give as satisfactory results as were desired, due to the fact that the oil was cooled too suddenly and did not have time, therefore, to properly crystallise, and consequently did not press easily.

Henderson patented a cooling apparatus that consisted of a jacketed iron trough having a U cross section and provided with a shaft that passed through its centre from end to end, and to this shaft were attached scrapers. The trough being filled with oil, and cold brine circulated through the jacket, the shaft was set in motion, and the rotating scrapers detached the oil that congealed on the cooled surface, and this treatment was continued until the whole of the contents of the trough had been reduced to the desired temperature, when, by opening a valve, the cooled mass could be discharged into a press with the aid of a pump. Macay and Baxter patented a very similar apparatus, which was put into use at the Bathgate Works, and

resulted in an improvement in the pressing quality of the solidified oil.

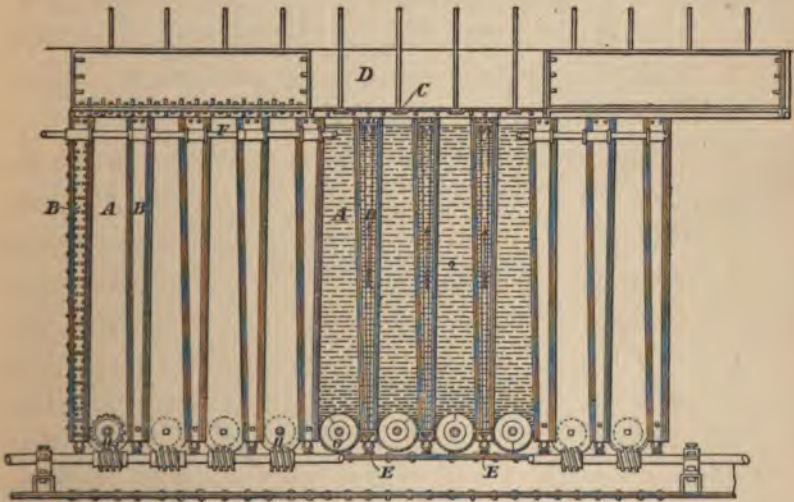
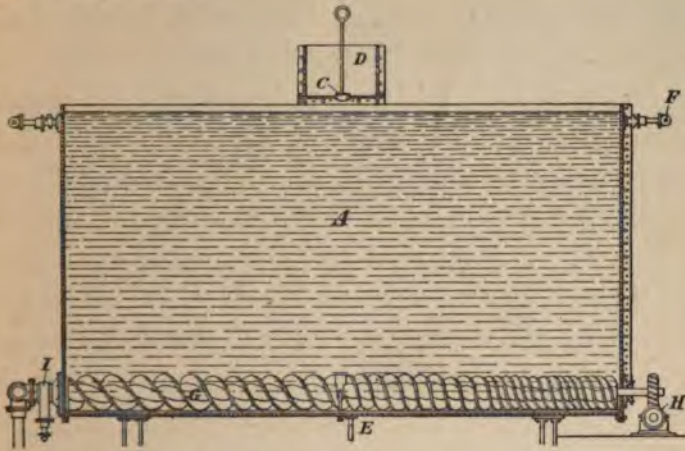

FIGS. 42 and 43.

In 1885 Beilby patented the apparatus shown in Figs. 42 and 43, and, without a doubt, it is the best form of cooling apparatus that has been so far designed.

It consists essentially of the wedge-shaped cells A and B, the former—in which the oil is cooled—being smaller at the top, and the latter, or brine cells, larger at the top than the bottom. The cells A are filled from the charging tank D by raising the plugs C, and the cooling medium (water or brine) is circulated through the cells B by pumping it in at the bottom through the valves E and allowing it to overflow at the top through the connections F. The oil cells are provided at the bottom with the helical screws or conveyors G, which can be revolved by the worm-gear H, and the flights of the conveyors have a gradually increased pitch towards the outlet I, thus preventing undue crowding of the cooled material towards the outlet.

The oil cells are filled in rotation, and as each one is filled, the cooling medium is allowed to circulate through its cells and absorb the heat contained in the oil. The cooling operation is continued until the temperature of the contents of the oil cell has been reduced to the desired point, when the flow of water or brine having been stopped, the conveyor of that cell is set in motion and the solidified oil is discharged by it through the valve I to the suction of the pump that supplies the filter presses. Owing to the shape of the oil cell being that of an inverted wedge, it is evident that as soon as the conveyor commences to discharge the material surrounding it, the cake above is deprived of support and therefore slides down on to the conveyor, and thus the latter is kept constantly and automatically supplied with material until the cell is emptied. Besides being an economical mechanical device—the machinery

only being in actual use for a comparatively short time—it is also designed with a view to doing the work from a correct theoretical point of view.

It must have been noted that by the use of the coolers previously considered, the oil was either very suddenly solidified or kept in constant motion while being slowly solidified. In the first case, the oil had not sufficient time to develop a definite crystalline formation, and, in the second case, the oils were unable to develop into large or perfect crystals, owing to the constant motion to which it was subjected. In the case of Beilby's cooler, the oil is not only cooled slowly, but is also allowed to remain at rest until the cooling operation is completed and results in the formation of large and well-defined crystals, which, after being once formed, may be crushed or broken in their passage to the presses without affecting the pressing quality of the material except, perhaps, to improve rather than deteriorate it.

Before leaving the question of coolers, a few words must be said in regard to an apparatus designed by McCutchon, of Young's Company, which was a great improvement over the other forms of continuous-motion slow-cooling coolers. It consisted of two cylinders A and B (Fig. 44) with an annular space C between them. In the inner cylinder was placed a conveyor D, that had about an inch clearance all round and was provided with the scrapers E, that was constantly pressed against the inner surface of the cylinder by the springs F. The end G was provided with a stuffing box H through which the conveyor shaft passed

and the end I was provided with a bearing J for the other end of the shaft, while the centre of the shaft was supported by the bearing K. The oil to be cooled was pumped through the connection L, and as it became solidified it was removed from the surface of the cylinder by the scrapers E, and, being carried along by the conveyor D, was finally discharged through the connection M. The cooling medium passed into the annular space through the connection N, and in its

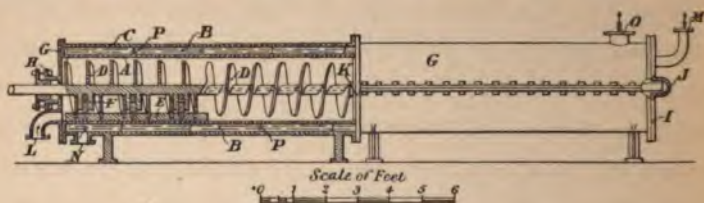

FIG. 44.

passage to the outlet O was made to travel in a spiral course formed by the inner projection P of the outside cylinder B.

The construction of this cooler could be improved by placing the connection N at the other end of the cylinder and doing the same also with the connection O. By making this change, the cooling capacity of the cylinder would be increased, and the resulting solidified material would be improved for the reason that the latter would leave the cylinder at the point where the cooling medium was coldest, while the inflowing oil would first be affected by the somewhat warmed cooling medium, and would thus not be so liable to be too suddenly congealed. The cooler as shown in the illustration is capable of reducing the temperature of 7000

gallons of oil from 60° F. down to 30° F. per twenty-four hours, and it takes one and a half hour for the oil to pass from one end of the cooler to the other.

In the earlier days of the industry, the solidified oil was placed in canvas bags and subjected to pressure in a vertical screw press. Later, a press worked by hydraulic power was built, and consisted of a large piston attached to a rod that descended into a perforated iron cylinder about 5 feet in diameter by 4 to 5 feet deep. A large canvas bag (of the same diameter but rather longer than the cylinder was deep) being placed inside the cylinder and filled with the solidified oil and then closed and tied, was subjected to pressure by forcing the piston down into the perforated cylinder. Although a large amount of oil was expressed and escaped through the perforations, it was found that owing to the great uninterrupted depth of material, the resulting wax still contained a large percentage of oil, and finally, therefore, the hydraulic presses were built as shown in Fig. 45. The cylinder A was cast with four lugs B, which carried the upright rods or guides C, surmounted by the heavy ribbed cast-iron head plate D. The ram E was provided at the bottom with a leather cup packing F, which latter was held in position by the plate G and screws H, and the upper end was surmounted by the ribbed cast-iron bottom plate I, which latter was provided with four lugs J that moved easily up and down the guides C. The press is filled by taking canvas sheets and placing on them (within given lines) a depth of two or three inches of the material to be pressed, and then folding them over to the centre from



each of the four sides, and when thus filled and folded

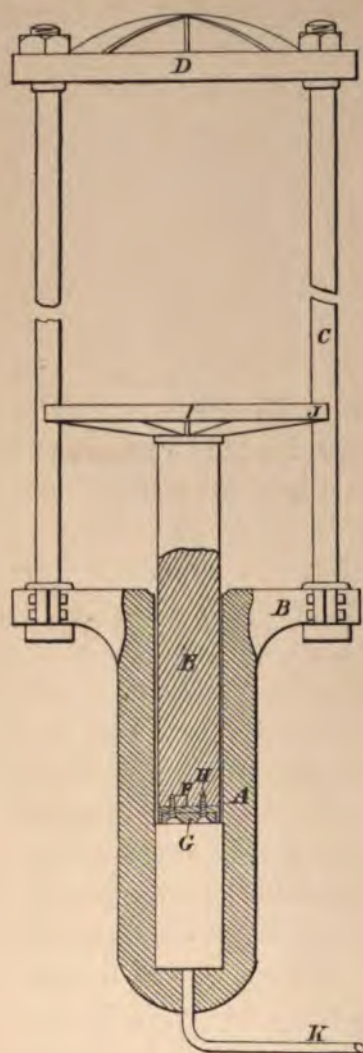

FIG. 45.

they are sandwiched between plates made of woven bamboo and then placed in the press. A press-full of these alternate layers of sheets and plates was subjected to a high pressure (by pumping oil or water in under the ram E through the connection K), which was maintained for a sufficient length of time to ensure all the oil being expressed and a dry wax being left in the sheets.

The above hydraulic press required very careful handling, when dealing with the lower cold-test oils, and, at the best, the work was sloppy and the

results unsatisfactory, and led to the use of filter presses. The side view of a filter press is shown in Fig. 46, the

construction of a filter press plate is shown (partly in section) in Fig. 47, and a cross section of the plate through X Y is shown in Fig. 48. The plates are constructed of cast iron with a bearing face A (Figs. 47 and 48) on all sides and a corrugated inner surface B, which latter is covered by the perforated wrought-iron plate C, while the whole is covered by the canvas sheet D. The centre of the plate is provided with a hole into which fits the brass sleeve E. This sleeve is provided with flanges and is made in two parts which

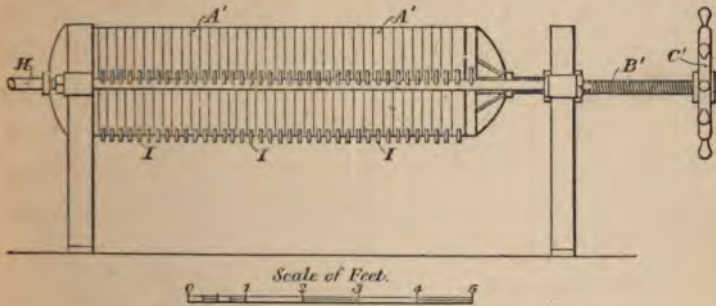
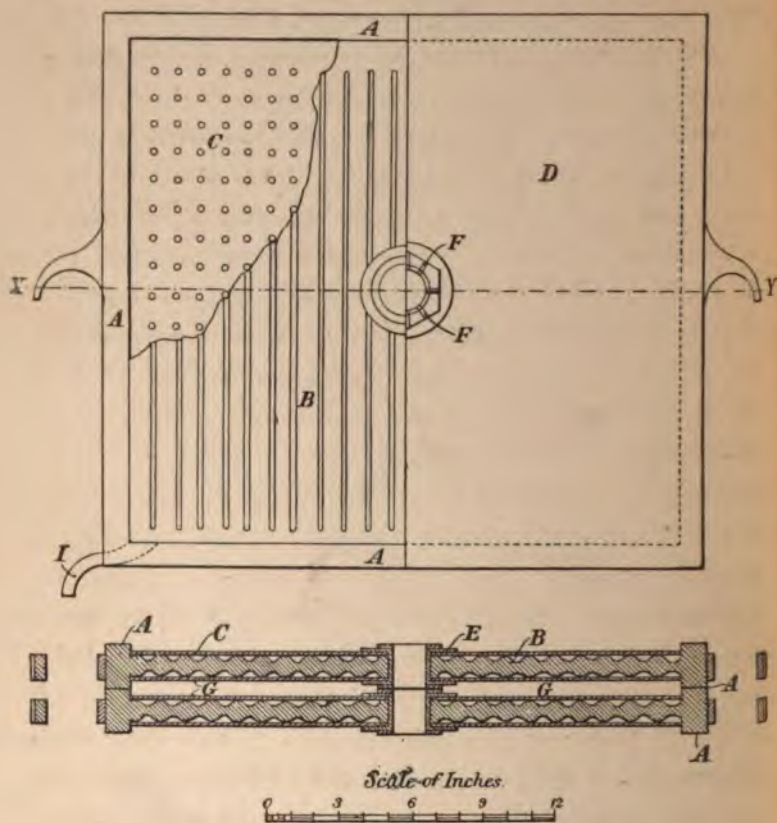

FIG. 46.

screw together, so that after a sheet with a centre hole has been placed on each side of the plate, one half of the sleeve is passed through the hole in the sheet and plate from one side, and the other half from the other side, and when these two halves are screwed tightly together, their flanges make a tight joint between the canvas sheets and perforated plates at that point. The hexagon nut portion of the flanges is provided with the slots F, and as, when two or more plates are placed together as shown in Fig. 48, the sleeves touch each other and thus prevent the centre of the plates from

bending and breaking when under pressure, and at the same time form a continuous passage, from one end of the press to the other, the slots form means of communication between the central passage and the space G.



FIGS. 47 and 48.

When a press is "made up" as in Fig. 46, all the plates A' and cloths are squeezed tightly together by the screw B' with the aid of the handled wheel C'. The cooled oil is pumped into the press through the connection H, and passing through the continuous passage

formed by the sleeves F, fills up all the spaces G, and, as the pressure rises, the oil filters through the cloths D, and passing through the perforated plate C, runs down the corrugations B and out through I, while the wax remains behind and fills the space G.

The perforated iron plate in the filter presses is designed to take the place of the bamboo plate of the hydraulic presses, but in reality there is a great difference in the utility of the two plates. In pressing a mixture of a liquid and solid, the liquid leaves the solid at right angles to the pressure, and, therefore, as the pressure on a cake of wax in a filter press is exerted through the slots F, it is evident that the oil will leave the cake in the direction of the perforated plate, but in the case of the hydraulic press, the bamboo plates are parallel with the pressure, and consequently no oil filters through to them (except at the very start) as it leaves the cakes of wax at the edges—which are the points at right angle to the pressure. When the oil is expressed from the wax, it passes away *between* the crystals and not through them, and as, by examining a cake of wax as it is taken from the hydraulic press, it will be seen that the crystals or scales lie parallel with the pressure (i.e. lengthways with the cake), it is proof that this assertion is correct, and also, that solid plates would give as good results in a hydraulic press as bamboo or slatted ones. In the case of the filter presses, the crystals or scales lie crossways of the cake, and again, therefore, parallel with the pressure, and consequently, perforated plates are necessary at the sides of the cake, in order to give the oil a free outlet.

## WAX REFINING.

In the early days, the refining of crude scale was partly accomplished by breaking the scale up fine and then placing it in perforated tin cans and washing it with successive quantities of naphtha. In this way a large portion of the oily colouring matter was removed, but as the demands of the trade became more exacting, other and more efficacious methods had to be adopted.

Most of the refiners adopted an acid and soda treatment for starting the refining process, and treated the melted crude scale (at a temperature of about 15 to 20 degrees F. above its melting point) with  $1\frac{1}{2}$  to 2 per cent. of  $148^{\circ}$  Tw. acid, and afterwards with  $8\frac{1}{2}$  lbs. of carbonate of soda (in the form of a  $4^{\circ}$  Tw. solution) to every 100 gallons of wax. The clear settled wax then received 25 to 30 per cent. of squeezings from the second naphtha treatment (see below), and was run into galvanised iron pans and allowed to cool—forming cakes about 24 inches long, 12 inches broad and 3 inches thick. The pans with their solidified contents were turned upside down on pieces of sacking, in which the cakes were then separately wrapped and then placed in a horizontal hydraulic press enclosed in woodwork and kept at a temperature of about  $100^{\circ}$  to  $130^{\circ}$  F. (according to the required melting point of the resulting wax). After being pressed for about two hours, the wax left in the sacking was thrown into a tank, melted and mixed with 12 to 15 per cent. of 755 specific gravity naphtha, and then run into pans and cooled. The cool cakes were hot-pressed, and the resulting wax was then steamed

with open steam for eighteen to twenty hours, and after settling for a few hours the wax was pumped to the char\* treating tank and mechanically agitated at a temperature of 240° F., with 2 per cent. of char. The char-treated wax having been settled for ten to fifteen hours, was next run through large sheets of filter paper (placed inside a perforated tin cylinder) in order to remove any char that had not settled out, and finally it was cast into cakes, cooled, packed and was then ready for the market under the name of twice-washed or semi-refined wax.

The squeezings from the first pressing were run into a still, and, the naphtha having been steamed off with open steam, the residue was converted into a cheap grade of wax by giving it a hot hydraulic pressing, and put on the market under the name of Recovered Wax.

The squeezings from the second naphtha pressing were used for the first naphtha treatment, as stated above.

With the introduction of caustic soda into the residuum stills, the colour of the crude wax was so improved that the acid and soda treatment was no longer necessary, and the wax was refined by being mixed with 55 to 56 per cent. of No. 2 squeezings (see below), cast into cakes and then hot hydraulic pressed under a pressure of about 30 lbs. on the square inch of the cake. The expressed oil was steamed in order to recover the naphtha, and the wax left in the still was either pumped amongst the crude wax or, after a treat-

\* See "Char."

ment with  $\frac{3}{4}$  per cent. of  $148^{\circ}$  Tw. acid, was packed into boxes and sold to the manufacturers of inferior and cheap candles.

The wax left in the hydraulic press was thrown into a tank and melted and then converted into semi-refined or, refined, wax by the following further treatments.

#### *Semi-Refined Wax.*

If this grade was required, the above melted wax was steamed for fifty-five to sixty hours, with 20 lbs. pressure steam, and was then treated with 0.5 to 0.6 per cent. by weight of char, filtered, cast into cakes, packed, and was then ready for the market.

#### *Refined Wax.*

In making this grade, the once-pressed melted wax was mixed with 60 per cent. of No. 3 squeezing (see below) cooled, hot pressed, thrown into a tank and melted, and was then known as twice pressed wax. The squeezings from this second pressing (= No. 2 squeezings) were used for the first naphtha treatment.

The twice-pressed wax then received its final treatment with 35 to 40 per cent. of fresh 755 specific gravity naphtha, and, after being cooled, pressed, &c., was treated with 0.6 to 0.7 per cent. char, panned and packed, was ready for the refined wax market.

The squeezings from this last pressing (= No. 3 squeezings) were used for the second naphtha treatment.

*Sweating Process.*

Owing to the great liability of explosions and fire resulting from the use of volatile naphtha in refining wax, and to the great cost due to the enormous loss of naphtha by evaporation, extensive experiments were made some twelve years ago to determine the practicability of refining wax by means of heat only. In the first experiments, an iron structure about 12 feet long, 4 feet wide and 6 feet high was constructed and fitted with sloping iron shelves about 9 inches apart, and the whole was heated by means of a steam coil placed on the floor of the structure. The iron shelves were covered with coarse cocoa-nut matting and the crude wax (cast into suitable sized cakes) having been laid on this and the doors being tightly closed, a little steam was turned on the coil. In a few hours, the oil commenced to sweat out of the wax, and then the temperature was gradually increased until finally the desired colour of wax was obtained, and then steam was shut off and the doors thrown open. The wax that remained on the matting was removed by hand, melted in a tank and then treated with char, and was ready for the market.

The experiments, as far as they went, were eminently successful, but, there was an opening for decidedly reducing the working costs of this process, and Norman Henderson quickly availed himself of the opportunity and invented and patented an apparatus that reduced the cost to such a low figure, that it will probably be many years before any cheaper method of refining wax is discovered. Henderson's patented apparatus consists



of a substantial brick building or "oven" 52 feet long, 13 feet wide and 12 feet high, in which is erected an iron framework composed of cast-iron uprights held together by iron piping, the latter acting also as heating coils. On these coils are placed iron trays 21 feet long,  $6\frac{1}{2}$  feet wide and  $5\frac{1}{2}$  inches deep, and  $1\frac{1}{2}$  inch above the bottom of each of the trays is secured (on piping or rods resting on angle iron that is riveted to the inside of the tray) a diaphragm made of 25-mesh brass wire gauze. All the trays—which number nine in height and two in length, making a total of eighteen—are fitted with adjustable side outlets at the bottom of one of the sides and midway between the two ends.

In order to charge the apparatus, water is first run into the trays, the outlets of which are raised so that the water just covers the diaphragm before it overflows through the outlet; then the trays are filled (to within an inch of the top) with melted wax, which latter is cooled by water that is kept constantly flowing in under the diaphragm, and by the air that circulates throughout the building. When the wax has been cooled to the desired point the water is shut off, the tray outlets lowered so as to drain the pans, and after the doors of the building have all been closed up tight, steam is admitted to the coils and the sweating process is thus started. The temperature to which the oven is heated depends upon the melting point of the wax under treatment and the required melting points of the resulting wax. A refined wax made by this process cannot be distinguished from a naphtha refined wax, but of course a sweated wax must be finished with a char treatment.

*Char.*

It was many years before the peculiar smell of a non-char treated wax could be removed and the present-day bluish-whiteness could be obtained. When wax was first refined, it was treated with either animal charcoal or fullers' earth, but the results were uncertain and, at the best, unsatisfactory.

In 1864, John J. Lundy, who was a large chemical manufacturer, of Leith, near Edinburgh, called the attention of Andrew Taylor, F.C.S. (owner of a small oil work at Uphall) to a by-product of the manufacture of "prussiate of potash," and suggested its possible use as a decolorising and deodorising agent for wax. Experiments proved that this prussiate of potash char did the work so perfectly and gave such superior results over anything that has so far been tried that Taylor immediately adopted its use, and until the secret of his success was discovered his waxes brought the highest prices of any in the market. Since this char became generally used for the final wax treatment nothing to be compared with it has so far been discovered, and it bids fair to hold its own for many years to come.

Having now followed the oil and gaseous products of the distillation of shale from start to finish, the various distillations and processes through which the oily products afterwards passed may be somewhat easier memorised or followed by studying Diagram II. Of course it must not be supposed that all the companies adopt exactly the same methods of distillation, fraction-

The Heavily Underlined Products are Ready for the Markets.

DIAGRAM. 2.

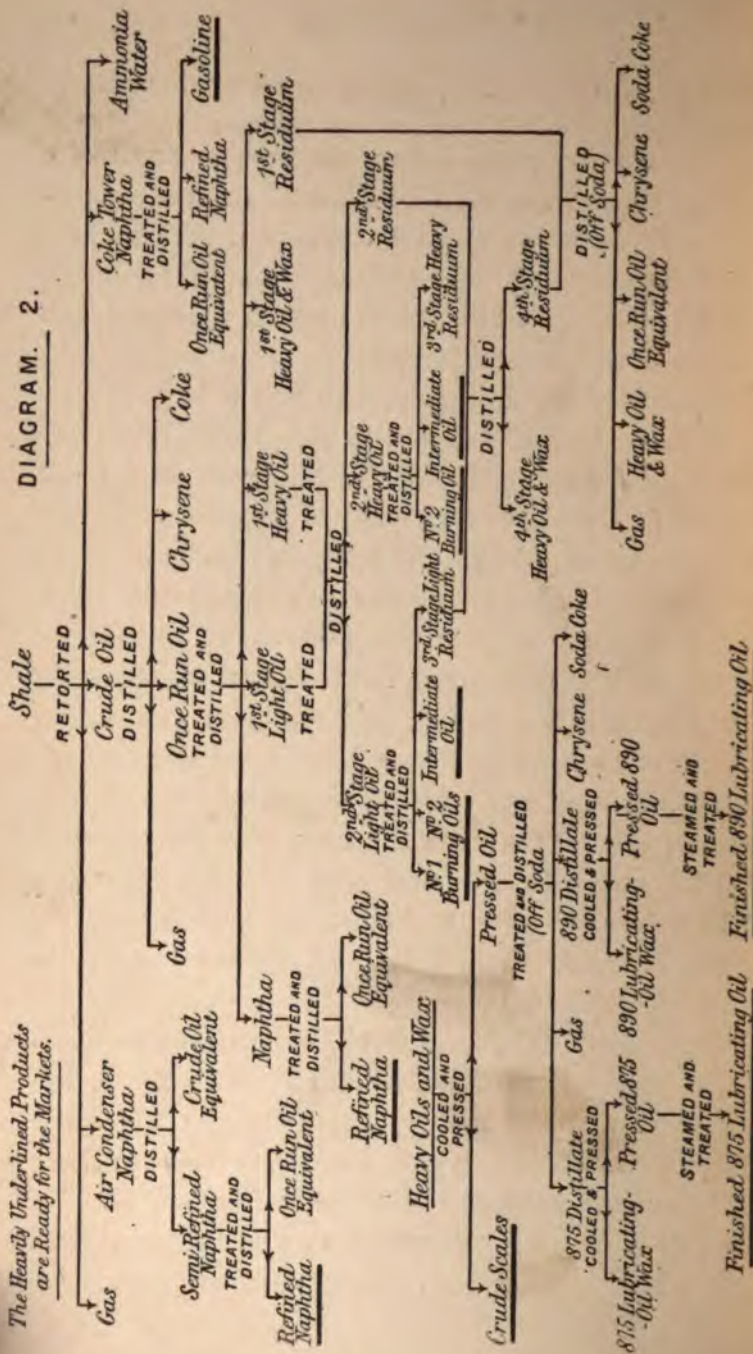

ation and treatment above described, as each company has its own fads, which finally result in finished products

DIAGRAM 3.

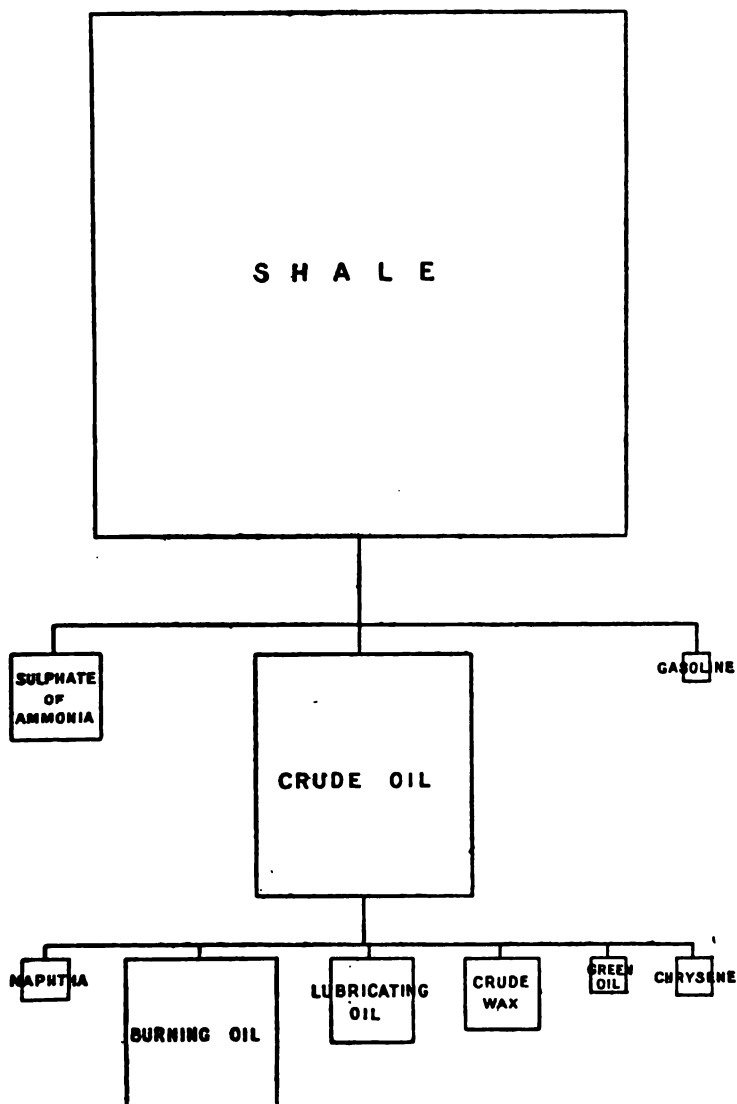

that are neither better nor worse than can be obtained by the above *modus operandi*.

Diagram III. has been prepared for the purpose of showing at a glance the relative yields of various products from shale.

## CHAPTER V.

## AMMONIA WATER.

IT was many years after the Scotch Mineral Oil Industry had been started before the value of the water from the coal or shale retorts was discovered. The water was looked upon as a necessary nuisance, and was run into the sewers that discharged into the small rivers or "burns," that ran past the various works, but in 1865 its value was discovered by accident by Robert Bell, of Broxburn, who kindly sent the author the following information:—

He (Mr. Bell), like the other oil-work owners, had been disposing of his retort water by running it into a small stream, and the latter became so polluted that the water was rendered undrinkable, and the trout and other fish were nearly all killed. The Rivers Pollution Commissioners were soon on Bell's track, and when the latter found himself entangled in an expensive litigation, he immediately stopped running the water into the stream and turned it into a field instead. Shortly after making this change, he noticed the ground over which the water ran was wonderfully productive, and that the grass grew apace. After turning this matter over in his mind he concluded that the water must have some properties that had so far not been credited to it,

and he at once set about experimenting with it, which experiments resulted in his starting the manufacture of sulphate of ammonia as a by-product of the distillation of shale, and this product was first placed on the market by Bell in May 1865.

#### USE AND IMPURITIES OF SULPHATE OF AMMONIA.

The sulphate of ammonia manufactured by the Shale Oil Companies in general is by no means a pure article, although some makes are considerably purer than others.

The principal impurities met with in these commercial sulphates are: iron, arsenic and more or less oily bases, but the presence and quantities of these impurities depend largely on the kind of sulphuric acid used in the manufacture. One of the companies used a "sulphur" acid,\* and as that does not contain either iron or arsenic, the sulphate of ammonia resulting from its use was consequently free from both those impurities. Other companies used "pyrites" acid,† and as that contains large quantities of both iron and arsenic, those impurities entered more or less into the composition of the sulphate made from that acid. Again, some of the companies used Recovered‡ Acid in the sulphate of ammonia manufacture, and in that case the sulphate was impregnated with more or less oily bases, and, if the original acid were a pyrites acid, iron and arsenic were also present.

\* That is, sulphuric acid made from sulphur or brimstone.

† That is, sulphuric acid made from iron or copper pyrites.

‡ See "Recovered Acid."

Considering that commercial sulphate of ammonia is principally used as a fertiliser, and that, largely on the sugar plantation of the West Indies, it is evident that the presence of the three impurities above named is not detrimental, and no one with common sense ought to take objection to either the smell or colour of sulphate of ammonia that is to be used as a fertiliser, and so long as it contains the guaranteed percentage of ammonia they should be content, because it is the ammonia that does the work, and the presence of the above impurities will not detract from the good results in any way. However, the various companies in trying to oust each other's product by expatiating on the superior colour and therefore purity of one make over another, has led the consumers to believe that a light-coloured sulphate is a better fertiliser than a dark-coloured one, and, consequently, it is necessary nowadays to manufacture as light coloured a product as possible in order to find a suitable market for it.

#### SULPHATE OF AMMONIA MANUFACTURE.

The general arrangement of the apparatus used in the manufacture of sulphate of ammonia is shown in Fig. 49, in which A is the still, B the acid, and C the alkaline "cracker boxes," D the settling tank, and E the evaporating box in the "ammonia house" F. The vapours from the stills pass into the main G, which supplies the cracker boxes through the connections H, and the spent water runs off through the connection I. As a large volume of sulphuretted hydrogen, carbonic



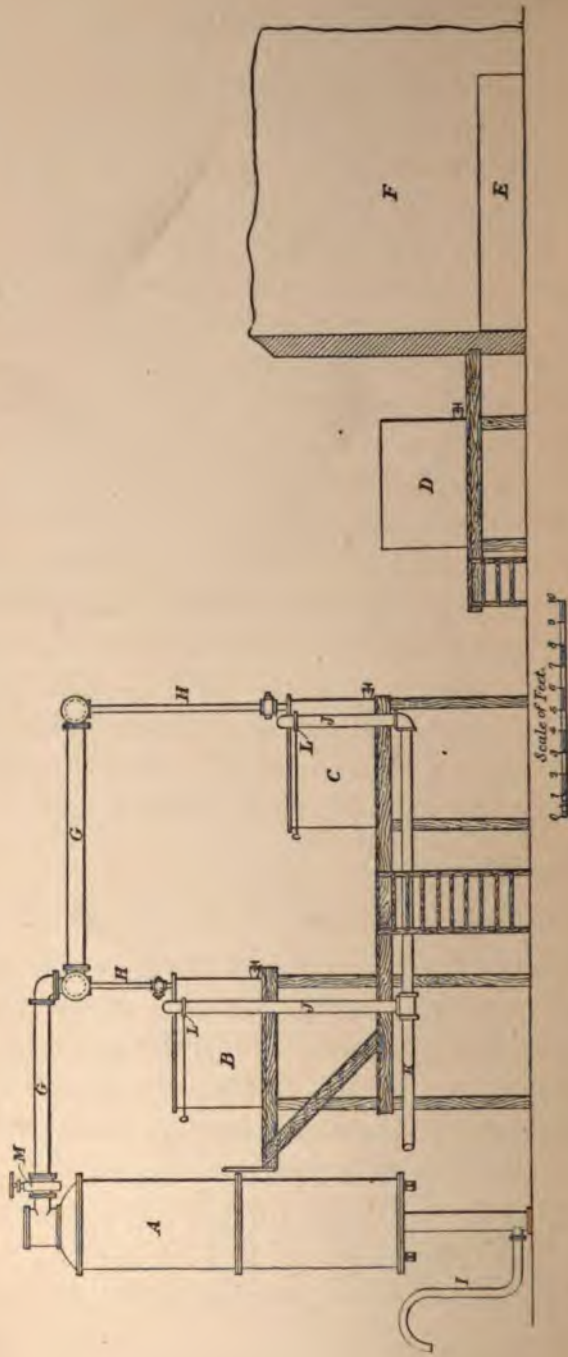

FIG. 49.

acid gas and steam result from the operation, and as this mixture would seriously pollute the atmosphere if allowed to escape, the cracker boxes are fitted with tight covers and provided with the outlets J that connect into the main K that conducts the vapours away to be disposed of in the way to be presently explained. When a cracker box is ready to be emptied, the damper L is closed so as to prevent the vapours from the other boxes backing up into it. All the stills should be provided with valves M, that enable a still to be shut off from the rest when repairs, &c., are needed.

Before explaining the working details, it will be wise to first examine the details of the construction of the apparatus so that the details of the manufacture may be more easily understood and followed.

#### AMMONIA STILL.

The method that was first adopted for extracting the ammonia from the water was to boil the latter in horizontal boilers and conduct the vapours through a main to the cracker boxes; but this method resulted in a considerable loss of ammonia, and was, generally, an expensive way of working. The loss of ammonia was due to the inability to drive off sufficient of the ammonia contained in the water, and as the spent water left in the boiler often contained as much as an equivalent of 100 grains of sulphate of ammonia per gallon when blown off into the sewer, it will be seen that the loss was considerable.

About the year 1882, Beilby patented the ammonia

still shown partly in section in Fig. 50, and although the general construction is not particularly original—being patterned after Coffey's still—it has one or two points that make it particularly well adapted for the purpose for which it is intended. The main body A of the still was composed of two castings securely bolted together, and on the upper end was bolted the feed and outlet connection B, and to the bottom, the pressure leg C. The object of the leg was to enable a sufficient depth of water being maintained in the still to overcome the internal pressure without trapping or luting the openings in the plates or otherwise interfering with the working of the still. The space from the under side of the casting B to the top of the casting C was filled with the cast-iron plates D, E, F and G. The plate D was constructed for the purpose of supporting the plate next above it at a suitable height from the casting C, and its construction is shown in plan in Fig. D<sup>1</sup>. The plates E and F were respectively concave and convex upwards, and by looking at the plans E<sup>1</sup> and F<sup>1</sup> it will be seen that the passages in the former were placed near the periphery, while the passages of the latter were central. As these plates were placed alternately in the space above D it is plain that the descending water and ascending steam had to travel in a zigzag course, and the steam, which was admitted through the connection H was thus brought into intimate contact with the descending ammonia water that entered at the top through the connection I. The reason for designing the plate G with the cup J on the top was to ensure an even distribution of the inflowing water over it.

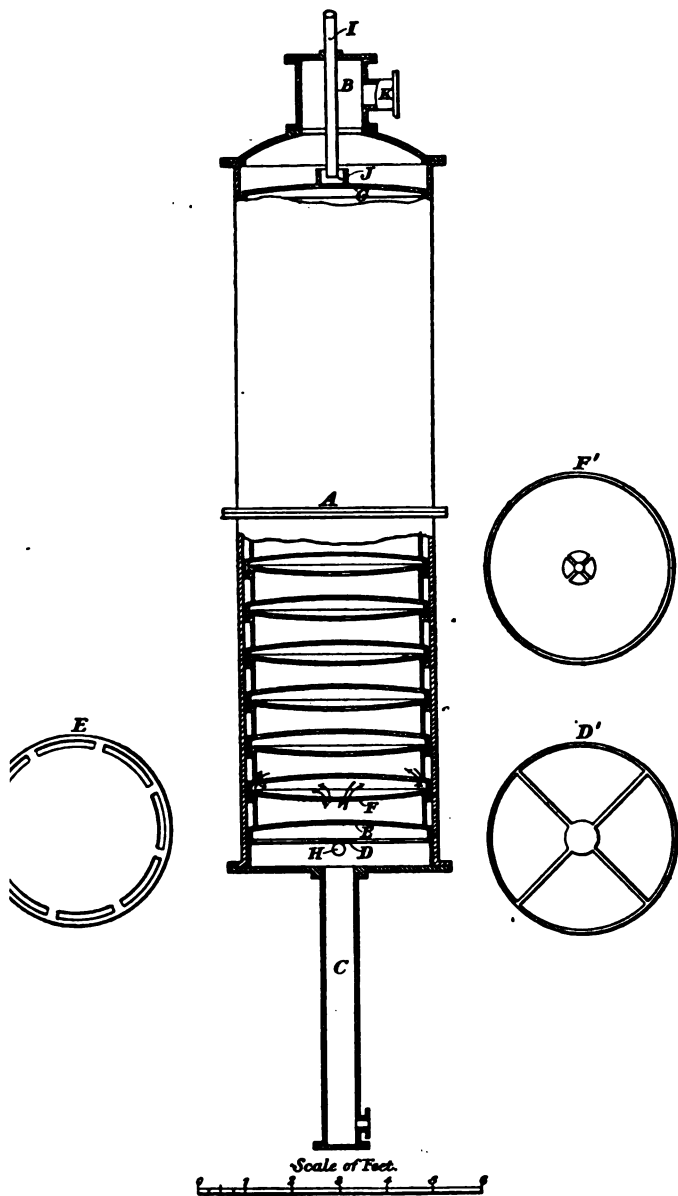

FIG. 50.

The action of the still was continuous ; the ammonia water entering at the top was deprived of the greater portion of its ammonia before it overflowed through the outlet I (Fig. 49), by the action of the 20-lb. pressure steam that entered at H and passed upwards and out through the connection K, carrying the ammonia vapours with it.

#### CRACKER BOXES.

The cracker boxes are the vessels in which the action between the ammoniacal steam and the sulphuric acid takes place, and they are called "cracker" boxes on account of the cracking noise that results from the steam blowing in amongst the comparatively cold contents of the boxes.

These boxes or tanks (A, Figs. 51 and 52) should be made of  $\frac{1}{4}$  to  $\frac{5}{16}$  inch iron, and be cylindrical in form. The inside must be lined with 10-lb. lead and the top should be provided with the wooden cover B having the sliding door C and the opening for the connection D.

As ammonia quickly destroys brass and other copper alloys, and as iron would be as quickly destroyed by the weak sulphuric acid, it is evident that the valves E need to be specially constructed. The usual method of constructing these valves is to cast the main part or body E' in lead and fasten to it the two iron lugs F which hold the cross bar G with its screw H in place. The end of the screw H is enlarged, so as to fit the space between the iron disc I and the two half-rings J. To the centre of the iron disc I is riveted a disc of

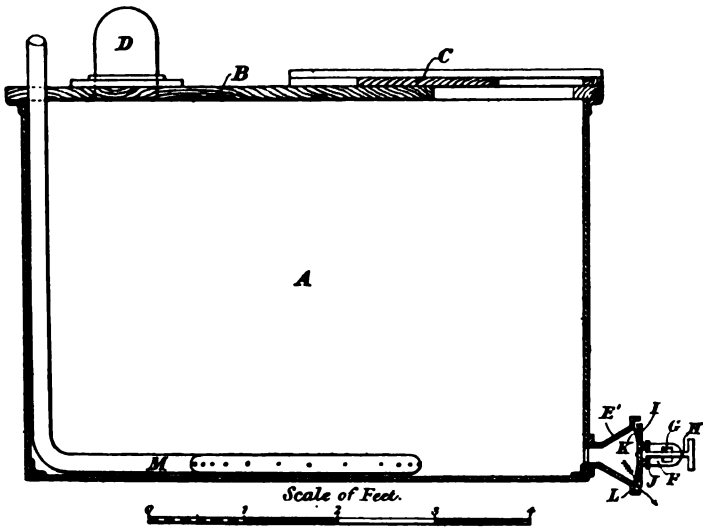
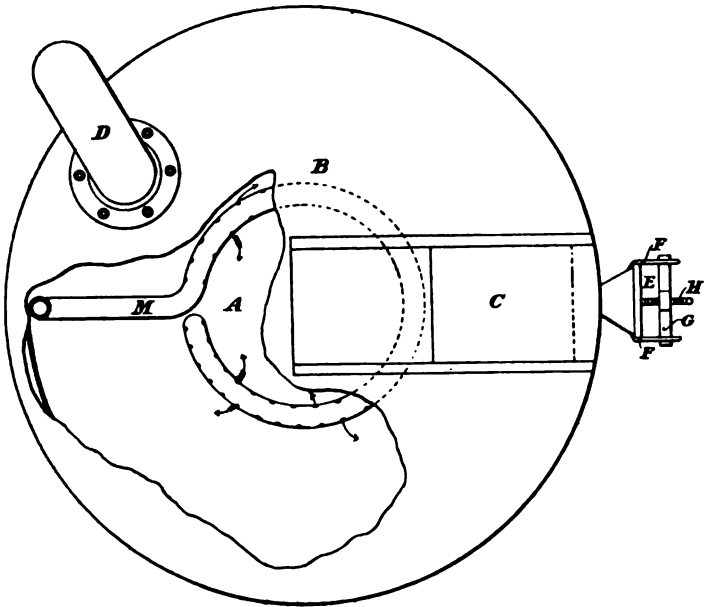

FIGS. 51 and 52.

rubber K, and the latter is riveted around its edge to the projecting flange L of the body E', but two or three inches of the bottom edge of the rubber are left unriveted, so that when the disc I is drawn outwards by the screw H, the contents of the cracker box flow out through the opening formed between the unriveted portion of the rubber and the body of the valve. When the iron disc is forced inwards by the screw, it forms a tight joint by pressing the rubber against the flanged body of the valve.

The ammoniacal steam is distributed in the cracker box by means of the perforated lead pipe M.

The cracker box is represented in Fig. 52 as having a flat bottom, but it is necessary in the case of the acid, and preferable in the case of the alkaline boxes to have the bottom somewhat dished and fitted in the centre with a connection closed by a lead plug actuated by a rod passing up through the cover. That construction allows of the boxes being periodically and thoroughly cleaned at a small cost for labour.

#### SETTLING TANKS.

The settling tanks should be constructed of the same weight material as the cracker boxes, have dished bottoms, be lined with lead, but need not be provided with covers, although it is better to have the latter, as they keep our dust and dirt.

## EVAPORATING BOXES.

These may be conveniently and cheaply constructed of wood lined with 10-lb. lead. The best sizes for these boxes is about 12 feet long,  $4\frac{1}{2}$  feet wide by  $1\frac{1}{2}$  feet deep. The inside must be provided with a 2-inch lead coil of about six horizontally parallel strands of pipe along each of the sides and ends, and so placed as to leave a clear space of 9 feet in length by  $1\frac{1}{2}$  foot in breadth in the centre of the box. Also, the coil should be supported about 3 or 4 inches above the bottom of the box.

## WORKING DETAILS.

Supposing the apparatus to be in working order, and two acid cracker boxes having been charged half full with acid, the steam is turned on the stills and the ammonia water feed started. The volume of steam is so regulated that the pressure in the still is not quite sufficient to cause the steam to blow out through the overflow I (Fig. 49), and the feed is so regulated that the "spent" water flowing from I does not contain more than a certain amount (the actual amount will be referred to later) of ammonia.

The ammoniacal steam from the stills is now allowed to enter one of the cracker boxes (by opening the cock on the connection H, Fig. 49), and the absorption of the ammonia by the acid is allowed to continue for three hours, at the end of which time the supply of ammoniacal steam to that box is shut off and opened to the other



box. The contents of the first box are now allowed to settle for two and a half to three hours, and are then transferred to an alkaline box (B, Fig. 49) by means of a light trough that can be placed under the valve N and reach across to the opening in the cover of B. As soon as the transfer is completed, the second acid box will have received sufficient ammonia, and its supply is therefore shut off and the ammoniacal steam allowed to enter B and blow through the contents for about one hour after the smell of ammonia first becomes apparent. About three hours' steaming are necessary in the alkaline box to ensure thorough saturation, and, consequently, by the time the contents of this box are saturated, the contents of the second acid box have been transferred to a second alkaline box and are ready to receive the ammoniacal steam as soon as it is shut off from the first alkaline box.

While the alkaline boxes are being steamed, the acid boxes are being recharged with acid, and so the operation goes on from one week's end to another.

As soon as the saturation of the contents of the alkaline box is completed, the valve is at once opened and the contents are run to the settling tanks D, where they are allowed to settle for six or eight hours, and if, at the end of that time, the liquor is free from any sediment it is charged into the evaporating or crystallising boxes E.

After the evaporating box has been filled to within 3 or 4 inches of the top, steam is turned into the coil and the liquor is boiled down to about one-third of its original volume, and about nine to ten hours are

required in order to effect this reduction. The steam is now shut off and the sulphate of ammonia crystals that lie in a thick layer on the coils and in the space between the coils are removed by means of long, broad wooden shovels and placed on sloping tables to drain. After all the crystals have been "fished" out, some 3 or 4 inches of mother liquor will be left in the box and mixes with the fresh liquor from the settling tanks when the box is refilled.

The crystals should be allowed to remain on the draining tables for five or six hours and then be transferred to the drying room, which latter must be heated by a steam coil or other means to a temperature of  $100^{\circ}$  to  $120^{\circ}$  F. After four or five days' exposure in the drying room (during which time the mass of crystals must be frequently separated and turned) the sulphate of ammonia should be quite dry and, after all lumps have been broken, ready for packing into bags and delivery in the market.

The latter part of the process could be greatly cheapened by placing the crystals as they are taken from the evaporating box into a centrifugal dryer fitted with a bottom emptying arrangement like those used in sugar refining, and the contents of the centrifugal dryer could then be emptied into a hopper that would feed a revolving cylinder. The cylinder should be about 12 feet long and 3 feet in diameter and provided on the inside with a snugly fitting spiral steam coil, the strands of which should be about 3 inches apart; one end of the cylinder should be about 3 inches lower than the other. The slanting position

of the cylinder, together with its rotary motion, will cause the sulphate of ammonia entering it through the hopper at the high end to travel slowly towards the lower end, and by the time the lower end is reached the sulphate will not only be perfectly dry, but will also be free from lumps due to the tumbling it would be subjected to in the cylinder. To complete the arrangement, the lower end of the cylinder should be placed over a hopper, from which latter the bags could be filled quicker and by one-third of the labour employed to do that work at the present time.

With a properly designed drying plant one man for each shift (day and night) could easily attend to the crystallisation, drying and packing of all the sulphate of ammonia turned out at any one of the Scotch works, and, if such an apparatus as above described were put into use it would pay for itself in a very few months.

As the valves on the acid cracker boxes are situated about 4 to 6 inches above the bottom, that depth would of course become filled with the settled precipitates if the boxes were not periodically cleaned by raising the plug that closes the hole in the centre of the dished bottom and washing the settlings or "mud" down into another cracker box kept for the purpose. After sufficient cracker boxes have been washed out to fill the "mud" cracker box the ammoniacal steam is turned into the latter, the resulting liquor is settled and as much of it as possible is run to the settling tanks. What is left in the box should then be washed with its own volume of water, steamed and settled; and the clear solution having been run to the settling tanks, the

residue left in the box can be removed and thrown away.

The settlings from the settling tanks should be treated in the same way as the settlings from the acid cracker boxes.

After the evaporating boxes have been running for a week or so, the mother liquor will become decidedly acid and the crystals of sulphate of ammonia will then be exceedingly small and hard to dry. Therefore the acid mother liquor should either be transferred to an alkaline cracker box and steamed, or else allowed to remain in the evaporating box, and be rendered alkaline by the addition of a fairly strong solution of aqueous ammonia.

#### CHEMISTRY OF SULPHATE OF AMMONIA MANUFACTURE.

The chemical action that takes place in the cracker boxes depends, to a certain extent, on the kind of acid used.

##### *" Sulphur " Acid.*

If this acid is used there will be no need of settling tanks, and only one cracker box will be required, as the acid does not contain iron and arsenical impurities, and therefore there will be no precipitates to settle out.

##### *Recovered " Sulphur " Acid.*

In the event of this acid being used, a separation of oily bases will take place when the acid has become

thoroughly neutralised by the ammoniacal steam, and, consequently, it will be necessary to allow the contents of the cracker box to settle for one and a half to two hours before drawing it off; and to provide a connection into which the bases can be run after the liquor has been drawn off.

### *Pyrites Acid.*

This acid, as we have already seen, contains iron and arsenic in solution.

All ammonia water from the retorts contains more or less sulphur in the form of sulphide of ammonia and sulphuretted hydrogen, and when the ammoniacal steam is turned into the acid cracker boxes a considerable volume of sulphuretted hydrogen is consequently evolved.

Sulphuretted hydrogen precipitates *arsenic* from an *acid* solution.

Precipitated sulphide of arsenic is *re-dissolved* by an *alkaline* solution.

Sulphuretted hydrogen precipitates *iron* from an *alkaline* solution.

From the above it must be evident that when a pyrites acid is used it is absolutely necessary to use both an acid and alkaline cracker box, if both of the acid's impurities are to be extracted. It is also evident that the arsenic is precipitated, by the sulphuretted hydrogen, in the acid cracker box, and thus necessitates the contents of the latter being settled for three hours before being transferred to the alkaline box, in which latter any arsenical precipitate would be re-dissolved.

We have seen that iron is only precipitated, by sulphuretted hydrogen, from an alkaline solution ; therefore if the ammonical steam were shut off from the alkaline box as soon as alkalinity was reached it is quite plain that little or no iron would be precipitated, and that, consequently, it is necessary to continue the process for an hour or so longer, in order to allow the sulphuretted hydrogen to precipitate the iron. As the sulphide of iron precipitate takes longer to settle than the arsenical precipitate does it should not be settled out in the alkaline boxes, as such procedure would necessitate increasing the number of those boxes, and an increased expenditure as compared with providing the cheaply made settling tanks.

#### *Recovered Pyrites Acid.*

This contains oily bases as well as the iron and arsenical impurities. Furthermore, the iron which was present in the original acid as ferrous sulphate has (during the passage of the acid through the refining and recovery processes) become oxidised and converted into ferric sulphate.

Sulphuretted hydrogen reduces ferric sulphate to ferrous sulphate.

Sulphuretted hydrogen will not commence to precipitate iron until the latter is in the ferrous state.

It is plain, therefore, that when recovered acid is used, the ammoniacal steam must be passed through the alkaline boxes for a longer period *after saturation* than in the case of the original pyrites acid, or, otherwise, the whole of the iron will not be reduced or

completely converted into sulphide, and in that case the liquor will not settle properly.

From the foregoing it will have been noticed that besides noxious gases and steam being carried off through the connections J and K (Fig. 49), a large escape of ammonia in the same direction must also take place (from the alkaline boxes), and if these gases, &c., were passed in under furnaces and burnt, it must result in a large loss of ammonia. In order to prevent that loss it is evident that the vapours from the cracker boxes should be led back to, and forced into, the retorts, either by the use of a steam injector or other suitable apparatus.

If arsenic is present in the liquor that is evaporated to crystallisation, it will give the sulphate an objectionable yellowish colour. If iron is present it will give a reddish-brown colour. More or less bases are always present in the crystallised sulphate if recovered acid is used, and invariably gives the sulphate a peculiar disagreeable odour, besides a reddish colour, which latter becomes more pronounced the longer the sulphate is kept and exposed to the air.

Two gallons of ammonia water contain enough sulphur to precipitate the whole of the arsenic and iron contained in one gallon of 63° Tw. recovered acid, and as one gallon of the latter will neutralise about 120 gallons of ammonia water (containing the equivalent of 500 grains of sulphate of ammonia per gallon), we see that the ammonia water contains about sixty times as much sulphur as is necessary to precipitate all the arsenic and iron, and therefore there is no excuse for

having any of these impurities in the crystallised sulphate.

The vapours leaving the acid cracker boxes contain, on an average, 3·8 to 5·7 per cent. by volume of sulphuretted hydrogen; while those from the alkaline boxes contain 0·1 to 0·7 per cent.

The reduction in gravity from 63° or 70° (for the acid) to 44° (for the saturated liquor) is due partly to the absorption of the ammonia gas and partly to the

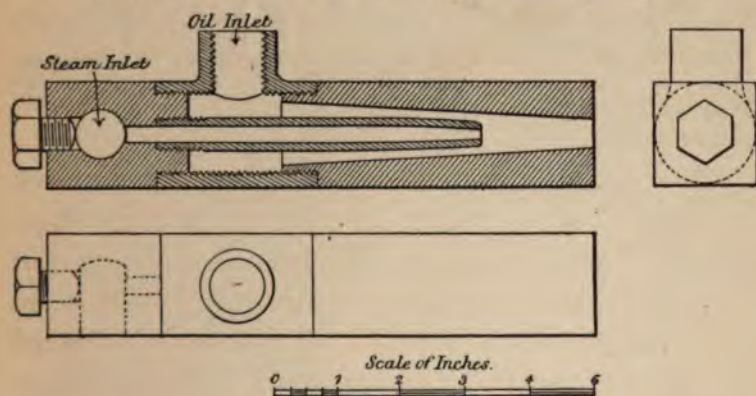

FIG. 53.

fact that the volume of the acid is increased about 20 per cent. by the steam that condenses in the cracker boxes.

The oily bases separated in the alkaline boxes should be run to a storage tank for liquid fuel. If properly burnt, a ton of oily bases is equal to fully three tons of coal. In order to get the best results, it is necessary that the bases should be injected into the furnace, and two very suitable forms of injectors for this purpose are shown in Figs. 53 and 54, which are designed for working with 20 to 30-lb. pressure steam.



The strength of acid used in this manufacture is of importance. If too weak, it entails a large expense for steam in order to effect the evaporation and crystallisation, and if too strong, the sulphate will crystallise out in the settling tanks and cause trouble.

Experience has shown that 44° Tw. is the most suitable strength for the sulphate of ammonia liquor that is run to the settling tanks. This gravity can be

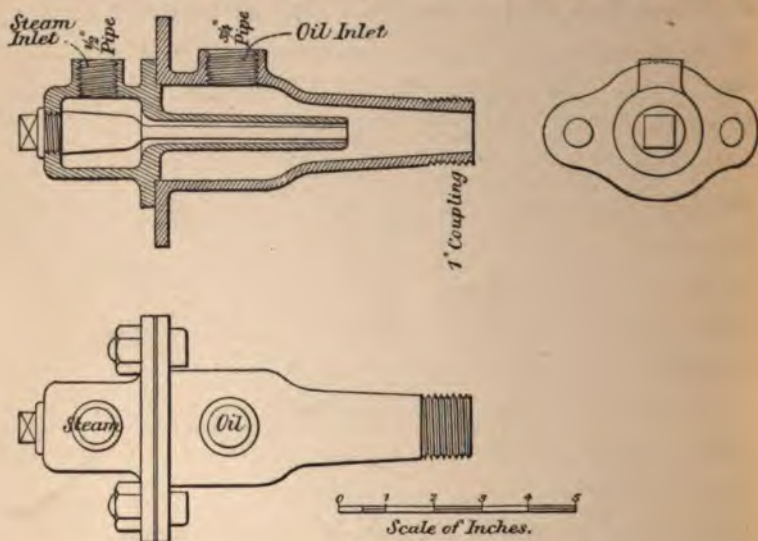

FIG. 54.

easily maintained, by carefully watching and regulating the gravity of the acid charged into the acid cracker boxes. If recovered acid is used, the strength should be 63° Tw.—if original pyrites acid is used, the strength should be 70° Tw.—which is equivalent to 63° Tw. in recovered acid, as the lighter gravity of the latter is due to the presence of the oily bases.

The strength of the ammonia water received from

the retort department is liable to large variations. The quantity of steam used in the retorts of course regulates the strength of the resulting ammonia water to a large extent, but if the quantity of steam used is the same in all cases, then the strength of the ammonia water will vary according to the seam of shale or form of retort used. As some seams of shale yield twice or three times as much ammonia as others, the water from some is correspondingly stronger than that from others. As the Young and Beilby retorts yield from three to six times more ammonia than the Henderson retorts do (from the same shale), the Young and Beilby ammonia water is consequently three to six times stronger than the Henderson. On an average, the strength of ammonia waters may be said to be 550 grains of sulphate of ammonia per gallon from the Henderson retorts and 2000 grains per gallon from the Young and Beilby retorts.

As regards the spent water overflowing from the ammonia stills, we have seen that in the case of the old form of "boiler" still, the blow-off water contained as much as an equivalent of 100 grains per gallon, but in the case of the Beilby still, the figures usually vary between 18.5 and 35.0 grains per gallon, and if the stills are carefully and properly watched there is no reason why the figures should exceed 25 grains.

One of Beilby's ammonia stills of the size shown in Fig. 50 will distil 7470 gallons of ammonia water per twenty-four hours, and will require about 360 gallons of water in the form of 20-lb. pressure steam.

On an average, a sulphate of ammonia plant uses

about 1800 gallons of water in the form of 20-lb. pressure steam per still per twenty-four hours. This includes the steam used for all purposes, such as stills, evaporators, drying coils, engines, &c.

Dry sulphate of ammonia after being sifted through a  $\frac{1}{2}$ -inch mesh sieve weighs  $53\frac{1}{2}$  lbs. per cubic foot if the measure is shaken while being filled, or 48 lbs. if the measure is filled without shaking.

Methods of determining the strength of ammonia water and crystallised sulphate of ammonia are fully described under the heading "Laboratory."

## CHAPTER VI.

## DISTILLING DATA.

THE life of the various stills depends greatly upon the treatment they receive at the hands of the stillmen, the quality of the oil distilled in them and the quality of the iron used in their construction.

If the stillman opens the furnace door and draws the damper leading to the chimney too soon after the distillation in a coking (= crude, heavy residuum and soda) still is finished, the current of cold air passing around the still is very liable to crack the heavy cast-iron bottom, and, therefore, before this means of cooling is resorted to, the red heat (of the coke left in the still) should be first reduced by blowing steam into the still for four or five hours. These stills usually start to crack after about the 100th to 150th distillation, and as these cracks are usually small or short, they can be easily and effectually repaired by placing a patch of wrought iron over them and securing the patch by bolts that are screwed into holes that are first drilled and tapped into the cast iron. The joint between the cast iron and the patch should be made tight by the use of a mixture of black oxide of manganese and oil.

Table XX. gives the life of the coking stills, or number of months they are in use until their condition becomes so bad that they have to be replaced by new ones.

TABLE XX.

Name of Still.	Average Number of Months in Use.	Average Number of Distillations Made.
Crude oil . . . . .	51	400
Heavy residuum . . . . .	31	310
Soda . . . . .	52	430

Before the use of steam in the stills, the life was very much shorter owing to the larger amount of coke left in the still and consequent higher heat necessary to "dry off" the still. The reason why the heavy residuum have a shorter life, and the soda a longer life than the crude oil stills, is because the first deposit more and the second less coke than the latter stills do.

The amount of coke formed in the stills is shown in Table XXI., and the weight given for the soda stills is minus the weight of the caustic soda placed in the still.

TABLE XXI.

Condition of Distillation.	Name of Still.		
	Crude Oil.	Heavy Residuum.	Soda.
	Lbs. of Coke per 1000 Gallons Charged.		
Without steam . . . . .	54.81	..	..
Steam after wax began to show in distillate. . . . .	51.18	..	..
Steam throughout distillation . . . . .	37.33	45.00	15.30

The life of the light oil stills is many years, and they practically never need to be wholly replaced, as they are not subjected to any very excessive heat, and, if properly looked after, an occasional patch on the bottom or a new bottom once in a great while is all that is really necessary.

The quantity of steam used in the various distillations is shown in Table XXII., and is expressed in gallons of water. The pressure of the steam should not exceed 20 lbs. per square inch, and it is important that the pressure at the boilers should be kept steady, as a fluctuation seriously affects the running of the stills and the quality of the distillate.

TABLE XXII.

Name of Still.	Gallons of Water per 100 Gallons of Distillate.
Crude (throughout) . . . . .	14.3
1st stage { (from start to 850 sp. gr.) . . . . .	10.0
{ ( " 850 sp. gr. to finish) . . . . .	14.3
2nd " (throughout) . . . . .	10.0
3rd " light " . . . . .	10.0
" " heavy " . . . . .	14.0
4th " " . . . . .	15.0
Heavy residuum { (from start to dark colour) . . . . .	15.0
{ ( " dark colour to finish) . . . . .	20.0
Soda { (from start to 860 sp. gr.) . . . . .	20.0
{ ( " 860 sp. gr. to finish) . . . . .	25.0

TABLE XXIII.

Name of Still.	Time Under Fire. (Hours.)		Length of Time Fed. (Hours.)	Capacity of Still. (Gallons.)	Runs per Week.	Per Distillation.		Per 5,000,000 Gallons of Crude Oil per Annum.		
	Total.	Running Distillate.				Fuel per Still. (Tons of 2240 lbs.)	Fuel for Steam. (Per Still.) (Tons.)	No. of Stills Required.	No. of Men.	
						Day.	Night.			
Crude . . . . .	22	12	..	1800	2	1.4	0.34	27	5	3
1st stage. . . . .	27	15	..	5000	1	6.0	0.83	10		
2nd " . . . . .	130	120	120	"	1			4		
3rd stage light . . . . .	110	100	100	"	1	10.6	1.30	3	3	2
" " heavy . . . . .	37	17	..	"	2			1		
4th " . . . . .	25	14	..	"	2			1		
Heavy residuums . . . . .	20	9	..	1150	2	3.2	1.0	8	4	8
Soda . . . . .	24	9	..	1800	2	3.0	0.83	14		

Table XXIII. shows the length of time a distillation takes, the length of time the light oil stills are fed, capacities of the stills and the amount of fuel required to effect the distillation, and, also, the amount of fuel required to raise steam for use in the stills, to run the pumps and warm the tanks containing the heavier distillates, and other information.

#### PRESSURE STILLS.

It has been seen that when an oil is distilled very slowly it is decomposed with a breaking up of the heavier or high specific gravity oils into lighter or lower specific gravity oils; if this slowness of distillation is coupled with high pressure in the still, the decomposition that takes place is greatly increased, and, therefore, it was customary before suitable outlets were found in the market for products that were too heavy for burning oil and too light for lubricating purposes, to distil them in pressure stills and convert them into marketable products.

The stills used for this purpose were made of boiler plate, cylindrical in form, and placed horizontally over the furnace. On the upper side of the still was riveted a dome of about 3 feet in diameter and 2 feet 6 inches high, and provided with a couple of large hand-holes on opposite quarters of the side and a swan-neck (leading to the condenser) on the top. A 3-inch lever safety valve was attached to that portion of the still covered by the dome and was weighted so as to maintain a given pressure in the still.



The still having been charged and the fire lighted, the distillation did not start until the pressure was sufficient to raise the safety valve, and when that pressure was reached, the vapours escaped into the dome and then passed through the swan-neck to the condenser. The stills were usually run under a pressure of 40 lbs. per square inch when new, but after being in use a few months the pressure was reduced, and this reduction was increased with the age of the still until (when the stills were too old for safe working and had to be replaced by new ones) the pressure was finally only 8 lbs. per square inch.

Oils of 845 to 860 specific gravity when distilled *once* under a pressure of 40 lbs. per square inch will yield 50 to 70 per cent. of an oil under 820 specific gravity at the worn end. If the residues of two of these stills are charged into another still and distilled under 40 lbs. pressure they will yield another 8 to 10 per cent. (calculated on the original oil).

Now that a market has been found for the intermediate oils the pressure distillation is not so often resorted to.

It has been claimed that the same results as those obtained from pressure stills can be obtained by distilling the oil up through a column 11 feet high. If the oil to be distilled were a heavy lubricating oil, the effect of making the vapours rise 11 feet higher than usual before they could escape to the condenser would surely result in more or less light oil being formed, but the columns, as might naturally be expected, failed to cause any appreciable extra amount of "cracking" (over

an ordinary still) when the still was supplied with the grade of oil charged into pressure stills.

The comparative results from distilling an oil through the column and through the ordinary connection of a still are given in Table XXIV. The specific gravity of the oil charged into both stills was 815, and the distillation was continued until both bulk specific gravities were 805, with the result that the still fitted with the ordinary connection yielded 2 per cent. more distillate than the still fitted with the column.

TABLE XXIV.

Time.	Ordinary Connection.		Column.	
	Sp. Gr.	Temperature of Vapour, ° F.	Sp. Gr.	Temperature of Vapour, ° F.
At start . . .	768	392	766	385
1 hour at start . .	780	428	781	392
2 hours at start . .	790	446	787	410
3 " " . . .	794	464	792	419
4 " " . . .	798	473	798	446
5 " " . . .	804	491	804	464
6 " " . . .	808	504	812	482
7 " " . . .	815	514	817	498
8 " " . . .	817	520	824	518
9 " " . . .	822	532	828	538
10 " " . . .	825	543	832	568
11 " " . . .	828	556		
12 " " . . .	832	574		

## CONTINUOUS DISTILLATION.

Henderson, of the Broxburn Oil Company, patented a continuous distillation apparatus (some nine or ten years ago), which consisted of three stills (similar to light oil stills) connected together by a suitable arrangement of pipes, and the stills were "set" so that the oil flowed from one to the other and maintained a certain given level in each still. The furnace fires were so regulated that each succeeding still was kept at a higher heat than the previous one, and in that way the first still (i.e. the still that received the feed) distilled off all the oil that would vaporise at the temperature of that still, and the residue constantly passed on to the next still, where it vaporised as far as the heat of that still would allow, and then passed on to the third still. The temperature of the third still was not sufficiently high to coke the still, and the steam of residuum from this still was conducted to a battery of four or five coking stills, where it was distilled to dryness.

This method of conducting a "feed" or continuous distillation certainly gave a better fractionated and more homogeneous distillate than that obtained from the one-still-feed-distillation, but no feed still will give as homogeneous an oil as an unfed still for this reason:—Suppose the temperature of the still is high enough to distil off 10 per cent. of the oil charged into it, or, say, the temperature is 450° F. Again, suppose the oil fed to the still starts to boil at 375° F. Now it is quite plain that if the 375° boiling point oil is liberated in a still where the temperature is 450° F.

there must be a sudden evolution of light vapours that will be so great that these vapours will mechanically carry away vapours or oil of a very much higher boiling point and specific gravity, and, therefore, a proper fractionation or separation of the light and heavy vapours cannot be accomplished.

If stills of 50,000 gallons or so capacity were used in place of 3000 to 5000 gallon stills, there would be no need of resorting to continuous distillations, and far better products would be obtained.

#### CONDENSERS.

The area of the condensing surface of the condenser worm and the diameter of the coils largely affect the running of the still and the quality of the distillate. There should be sufficient outlets from the still to allow of the oil in the still being kept in contact with the heat for only the shortest length of time necessary to ensure a proper separation of the impurities intended to be removed by the distillation. The condensing capacity should be sufficient to allow of the still being run at a maximum rate without causing loss of vapours due to imperfect condensation, and, in order to ensure this, there should be 1 square foot of condensing surface for every gallon of oil distilled per hour for heavy oils;  $1\frac{1}{4}$  square feet for burning oils; and  $1\frac{3}{4}$  to 2 square feet for naphtha or other very volatile oils.

As regards the size of the condenser worm. The internal area of the cross section of the worm at the inlet to the condenser should be 0.05 square inch per

gallon of distillate per hour, or if the distillate ran at the rate of, say, 200 gallons per hour, the size of the worm should be  $\left(\sqrt{\frac{0.05 \times 200}{0.7854}} = \right) 3.102$  inches in internal diameter. That size should be continued for about one-third the total length, and then reduced to  $2\frac{1}{2}$  inches for the next third, and to 2 inches for the last third.

TABLE XXV.

Name of Oil or Wax.	Sp. Gr.	Boiling or Melting Point.	Latent Heat of Vaporisation.	Vapour Density.	Specific Heat.
Gasoline . . .	642	70° F.	100.2° F.	..	0.5800
Naphtha . . .	720	115° F.	100.6° F.	3.005	0.5687
"    "    "	756	175° F.	133.5° F.	3.190	0.5104
Burning oil . . .	810	260° F.	105.4° F.	4.270	0.4991
Intermediate . . .	843	545° F.	..	7.770	0.4950
Marine . . .	836	..	..	..	0.4561
Pressed oil . . .	885	..	..	..	0.4413
Lubricating oil . . .	865	..	..	..	0.4492
"    "    "	890	..	..	..	0.4441
Refined paraffin wax	..	81 $\frac{1}{2}$ °	..	..	0.5584
"    "    "	..	118 $\frac{1}{2}$ °	..	..	0.4164
"    "    "	..	120°	..	..	0.4069
"    "    "	..	130°	..	..	0.3659
Stearine . . .	..	128°	..	..	0.3529

In figuring out the sizes of condenser worms it is always wise to leave a wide margin, as it allows of the size of the still being increased at any time without

necessitating altering the condenser, and it also allows of the still being pushed (i.e. run faster than usual), as is often necessary in the case of the still starting to leak, &c.

The quantity of water necessary to effect the condensation of the oil vapours and cool the distillate to any desired point, can be calculated by the aid of the specific and latent heat figures given in Table XXV. For an example, we will suppose that we have 1000 gallons of 756 specific gravity naphtha to distil, and that the distillation will be conducted at the rate of 100 gallons per hour, then :—

1000 gallons at 756 specific gravity = 7560 lbs.

The latent heat of vaporisation of 756 naphtha  
= 133.5° F.

Therefore  $(7560 \times 133.5 =)$  1,009,260 thermal units will have to be extracted from the vapours in order to condense them to a fluid of 175° F. temperature. The condensed fluid (i.e. distillate) has to be cooled to 60° F., and as the specific heat of the distillate is 0.5104 (water being 1.000) the amount of heat that will now have to be extracted will be  $(7560 \times 175 - 60 \times 0.5104 =)$  443,741 thermal units, therefore the total thermal units to be extracted will be  $(1,009,260 + 443,741 =)$  1,453,001. As the distillation will take ten hours, the number of thermal units per hour to be absorbed by the condenser will be 145,300. We will now suppose that the initial temperature of the condensing water is 50° F., and that the temperature of the overflow will be 80° F. As the specific heat of water is 1, and the temperature of the

water will be raised  $30^{\circ}$ , each pound of water will therefore absorb 30 thermal units, and as 145,300 thermal units have to be absorbed,  $(145,300 \div 30 =)$  4849 lbs. ( $= 484.9$  gallons) of water per hour will be required.

The above figures are based on the assumption that the boiling point of the naphtha would be  $175^{\circ}$  F. throughout the distillation, but this, of course, would not be the case, and more water than the above figures call for would be required. Also, a condenser is never perfect in its action owing to the worm becoming more or less covered with sediment, &c., and more water will be required again in this case; however, the approximate quantity of water required can be determined near enough for practical purposes by calculating as above and then adding 10 per cent.

## CHAPTER VII.

## TREATING DATA.

AIR *versus* MECHANICAL AGITATION.

THE kind of agitation used in the treatment has an important bearing on the "loss due to treatment." It is evident that if an oil that contains more or less light vapours is subjected to air agitation and the air so used is allowed to escape into the atmosphere, it will cause a loss over and above that due to the action of the acid, as the air will go away saturated with the light vapours. The author made a large number of experiments in order to determine the amount, &c., of this loss, and the average of the results will be found in Table XXVI.

TABLE XXVI.

Grade of Oil.	Length of Time Agitated by Air.	Specific Gravity at		Percentage Loss (by Volume).	Temperature of Oil during Agitation.
		Start.	Finish.		
Once-run oil . . .	30 min.	870	871	0.521	106° F.
1st stage light oil .	30 "	814	814	0.047	59° F.
"    heavy " .	30 "	854	854	0.023	63° F.
No. 1 burning oil .	15 "	810	810½	0.132	60° F.
Naphtha (semi-refined) . . . }	15 "	770	777	6.313	60° F.



TABLE XXVII.

Grade of Oil.	Regular Length of Time.		Per cent. by Weight of Acid Tar left in Oil Settled for regular length of Time.	After Setting 20 Hours.		Settled.	
	Agitated (Minutes).	Settled (Hours).		Per cent. by Weight of Acid Tar.	Grains of Free Acid per Gallon of Oil.	Hours.	Per cent. by Weight of Acid Tar.
Once run (air stirred)	30 + 30 + 30 <sup>x</sup>	16	0.069	0.053	39.67	6	0.10
" (mechanically stirred)	10 + 10 + 10 <sup>x</sup>	"	0.090	0.071	68.34	6	0.28
1st stage light (mechanically stirred)	30 to 45	12	0.037	0.021	23.05	4	0.06
" heavy	30 " 45	16	0.049	0.032	26.73	4	0.16
2nd stage light	30 " 45	12	0.041	0.031	27.12	3	0.08
" heavy	30 " 45	16	0.054	0.037	30.01	3	1.21
Pressed oil	50	20	0.239	..	160.29	16	0.26
875 "	30	20	0.093	..	71.82	..	..
890 "	30	20	0.162	..	91.00	..	..
Naphtha	15	10	0.009	0.002	3.16	..	..

<sup>x</sup> = three separate agitations and additions of acid, with short settlings between.

The figures in Table XXVI. clearly show that the agitation of semi-refined naphtha by air is out of the question unless a closed agitator is used, and the connections to the air-pump or "blower" are so arranged that the latter draws its supply from the top of the agitator, in which case any vapours passing off in the air would be returned in the air delivered from the pump. The loss is considerable even in the case of the once-run oil, but by the adoption of the arrangement above suggested could be entirely prevented.

The author would suggest, in the event of the expensiveness of centrifugal agitators standing in the way of their adoption, that the agitators be provided with tight covers, and that the whole of the air supply to the blower be drawn from the top of the agitator.

Table XXVII. has been prepared for the purpose of showing the length of time the various grades of oil are agitated and settled, and how much acid tar is left in the oil that has been settled for different lengths of time.

#### RECOVERED ACID.

About 90 per cent. of the sulphuric acid used in the treatment of the oils can be recovered by pumping the acid tars to lead-lined tanks and steaming them with open steam.

The length of time that the tars are steamed depends on the quality of the steam (i.e. a good dry steam takes longer than a "wet" steam) and the gravity desired for the resulting recovered acid, but, generally speaking, six to eight hours' steaming should be sufficient to

reduce the strength of the acid to 63° Tw. When the desired strength has been obtained, the steam is shut off, the contents of the tanks allowed to settle, and after any paraffin oil, &c., that rises to the surface has been skimmed of and pumped to the liquid fuel tank, the acid is ready for use as Recovered Acid.

#### SODA RECOVERY.

##### *Soda Tars.*

The practice of recovering the soda used in the treatment of the oils, was first started in 1874.

The soda solution used in the oil treatment is partly converted into sulphate of soda (by neutralising the free sulphuric acid left in the settled oils), and that portion cannot be remuneratively recovered, but the larger portion of the solution is neutralised by the phenol impurities of the oil, and the soda in this portion can easily be recovered by acidifying the soda tar with an acid that will form an easily decomposed soda compound. This is effected by passing carbonic acid gas through the soda tar, and as soda has a greater affinity for the carbonic acid than for the phenols, the latter are thrown out of combination and separate as an oily layer.

This separation was first effected by means of the apparatus shown in Figs. 55 and 56, which was constructed as follows. A perforated cylinder B was placed inside the cylinder A and securely held in position by the horizontal divisions C. The cylinder was supported on the frame D by the castings E, and was revolved (in

the direction indicated by the arrow) by the gears F. The two connections G and H fitted into the castings E,

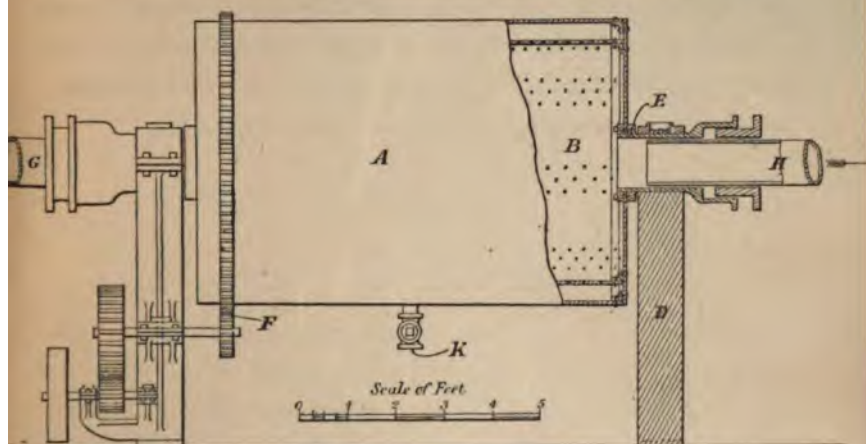

FIG. 55.

and the joints were made tight by means of glands and packing. The method of working was to first fill the cylinder with soda tars through the cock K to the height I, and then, having set the cylinder in motion, pass carbonic acid gas in through the connection G and allow it to escape through the connection H to a chimney. The soda tar was in this way saturated with carbonic acid, because as the cylinder revolved the tar was kept constantly pouring down through the gas in fine streams (as shown at J). The acidified liquor was drawn off through the cock K.

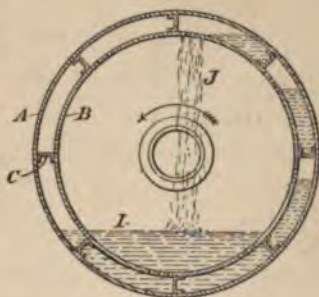

FIG. 56.

From four to six hours were generally sufficient to effect the conversion of the soda tar, and, as one of these cylinders was capable of handling 350 gallons of tar at a time, the capacity of the apparatus was from 1000 to 1400 gallons of soda tar per twenty-four hours—allowing ample time for charging and discharging.

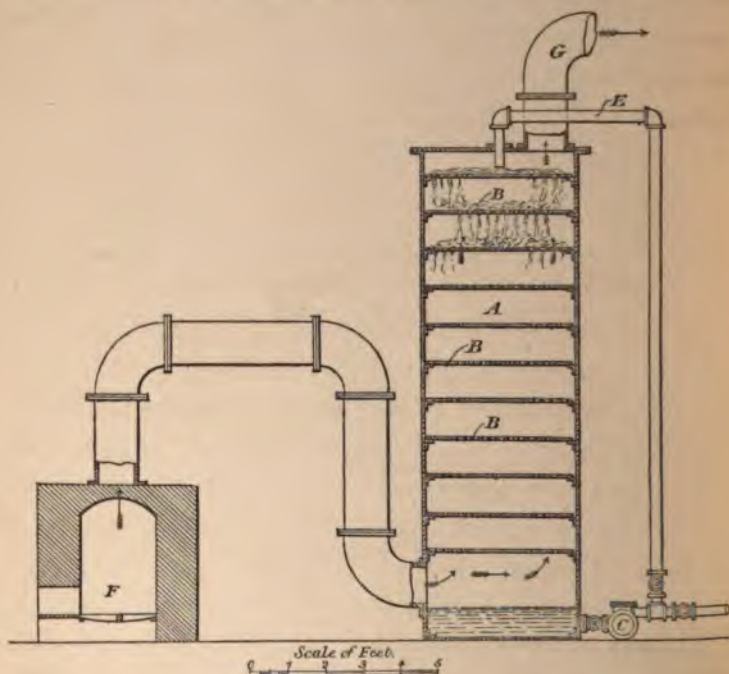

FIG. 57.

An improved soda recovery apparatus is shown in Fig. 57, in which the tower A was provided with the perforated plates B, and the soda tar was circulated by the pump C, which latter drew its supply from the bottom of the tower, and discharged it through the connection E, in at the top of the tower, and as the tar

passed down through the perforated plates, it came in contact with carbonic acid gas that was generated by slowly burning coke in the small furnace F, the necessary draught for which latter was supplied by the connection G being continued into a tall chimney. This apparatus was capable of handling 1500 gallons of soda tar per twenty-four hours, and the cost of working was very much less than in the case of the cylinder, and also the first cost was greatly in favour of the tower apparatus, as may be seen by the following figures.

	£	s.	d.
Revolving cylinder complete . . . . .	75	10	0
Carbolic acid gas generator . . . . .	10	0	0
Engine and pumps (combined) . . . . .	65	0	0
Total . . . . .	150	10	0

	£	s.	d.
Tower . . . . .	38	0	0
Carbonic acid gas generator . . . . .	10	0	0
Pump . . . . .	50	0	0
Total . . . . .	98	0	0

After the soda tar had been treated as above, it was pumped to a tank and allowed to settle for six to eight hours, after which the phenols that rose to the surface were skimmed off and pumped to the liquid fuel storage tank, and the carbonated soda liquor was then causticised with quick-lime, slaked and evaporated in V-shaped pans to the desired strength, and was then ready for use as "Recovered Soda."

*Soda Coke.*

The recovery of the soda from the soda coke resulting from the soda distillations is readily accomplished by piling the coke in heaps, setting fire to it and allowing it to burn to an ash.

This process should be conducted on iron plates and under a corrugated iron shed, so that the ashes may be protected from wind and rain until they can be transferred to a tank and washed with water. The watery solution after being settled free from any of the insoluble ash is mixed with the carbonated liquor from the soda *tar*.

## TREATMENT OF WASTE WATER FROM THE WORKS.

It must have become apparent to the reader that a very large volume of water is daily used in the various processes through which the oil, &c., have to pass, and that an oil work must discharge a large volume of waste water into the rivers or sewers in the vicinity. As it is a practical impossibility to prevent leaks from various oil pipes, &c., and as such leaks invariably find their way into the waste water conduits, it is necessary that an oil work should be provided with a main trap, into which all the drainings of the work should be led before being allowed to escape into the river or public sewers.

The proper construction of such a trap is shown in Figs. 58, 59 and 60, and consists of a brick and cement structure A (the top of which is level with the ground)

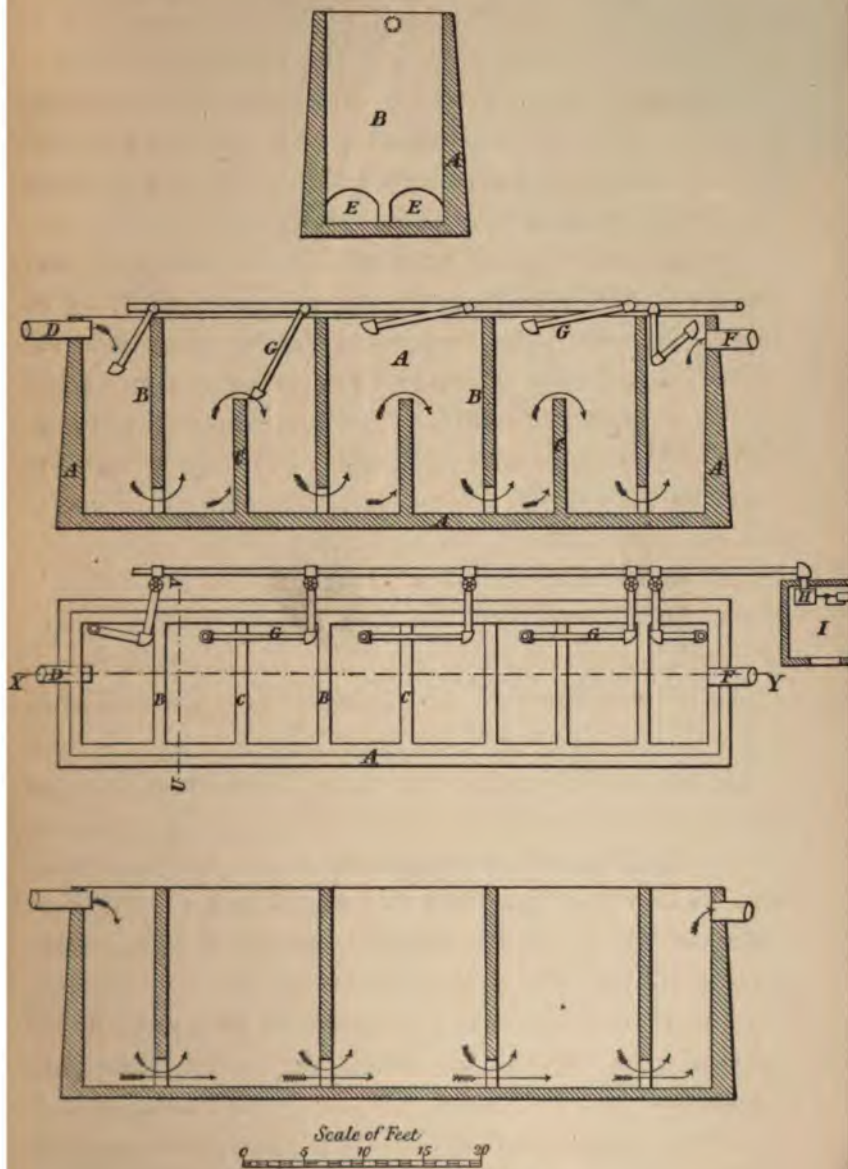

FIGS. 58, 59, 60 and 61.



divided by the walls B and C. The mixture of water and oil flows in through D, and the water accompanied by a certain amount of the oil descends and passes through the arched openings E, and, striking against the wall C, have to rise before the water and any oil it may still hold in suspension can again descend to the arched openings in the next wall (B), and so on, until the water finally flows away through the pipe F. By *making* the water take an upward course (and giving it plenty of space in which to do it so as not to cause sufficient current to mix the oil and water) after a downward one, tends to help any oil it may contain to come to the surface, whence it is pumped off through the swinging connections G, leading to the pumps H in the pump house I. It is important that the walls C should not be continued up high enough to cause any perceptible current on the surface, and, in fact, there should be a distance of 6 to 7 feet between the top of the walls and the top of the trap.

If the walls C are omitted, as shown in Fig. 61, a large amount of oil will pass through to the outlet F, because the oil held in suspension in the water will be free to flow through from one end of the trap to the other, as shown by the straight arrows, and only the lighter oils will rise to the surface.

The Rivers Pollution Commission are exceedingly particular as regards the water discharged into the rivers, &c., and inspectors pay frequent visits to the various works to see that the law is properly obeyed.

The visit of one of these inspectors to the Bathgate work in the days when the late James Young was in

constant attendance there, led to an incident that Young was never tired of reciting. The inspector in question thought he detected the taste of paraffin products in the small stream that flowed past the work, and immediately saw Young in regard to it, and, accompanied by the latter gentleman, went back to the lower end of the work and again tasted the water, and invited Young to do the same; but the latter declined, and suggested that they should walk up stream, and that the inspector should taste the water at some point above the work, so as to make sure that the Bathgate work was to blame. The inspector considered that a fair proposition, and as they walked up stream he kept on tasting the water and always finding indications of paraffin products, and, finally, as they rounded the base of a slight hill some distance above the works, Young exclaimed, "There's the source of the paraffin products you taste." The inspector looked in the direction Young indicated, and seeing half a dozen very dirty looking miners bathing in the river concluded to let the matter drop, and, furthermore, did not bother Young again for many months.

## CHAPTER VIII.

## LABORATORY.

THE work done in an oil works laboratory is usually of a very varied character, from the simple oil tests to the analyses of the various chemicals, &c., used in, and the by-products resulting from, the manufacture of shale oils.

The method of testing the various products will first shortly be considered.

## SOLIDIFYING POINT.

When testing the distillate from a still for wax, the quickest and simplest way is to have a beaker or tumbler filled with water at a temperature of three or four degrees lower than the desired solidifying point and allow a drop of the distillate to run down the outside of the glass. If the "drop" reaches the bottom without showing any signs of wax, the solidifying point is too low, but if there are signs of wax the distillation must be carefully watched, and the distillate tested every few minutes until (when the drop will not traverse more than an inch before it solidifies) the required solidifying point is reached.

In determining the solidifying point of a crude or

other oil containing a large amount of wax, the author would advise the following method being adopted:—

A couple of inches of a long bulbed thermometer are dipped into the heated oil and then quickly held in a nearly horizontal position between the thumb and fore-finger of both hands and slowly revolved, while at the same time the position of the thermometer is constantly changed, so that at one time the bulb is somewhat lower and then somewhat higher than the other end. The adhering oil will hang as a long horizontal globule from the under side of the bulb, and is prevented from dropping off by the constantly rocking and revolving motion of the thermometer, which motion also ensures the oil being uniformly cooled by constantly exposing fresh portions of it in a thin film on the upper side of the bulb to the cooling action of the air. Eventually, the globule will commence to thicken and revolve partly with the bulb, and finally become so thick that it will remain stationary in whatever position the thermometer is held, and as soon as that point is reached, the temperature must be quickly read. Solidifying points taken in this way agree very closely if ordinary care is exercised and there is not too great or too little difference between the temperature of the air and the solidifying point of the oil—the difference should be about  $10^{\circ}$  to  $20^{\circ}$  F.

#### SETTING POINT.

The name of this test is very misleading, and a far more appropriate name for it would be “Cold Test.”

The test can be made in two ways, to suit the nature

of the oil to be tested : if the oil is light coloured, bright and free from moisture, a depth of about 2 inches of it is poured into a test tube (about 1 inch in diameter by 6 inches long) and a long bulbed thermometer having been placed in the oil, the tube is immersed in a freezing mixture. As soon as the oil has solidified the tube is removed, the outside wiped dry, and then held up in front of a window and stirred with the thermometer (as

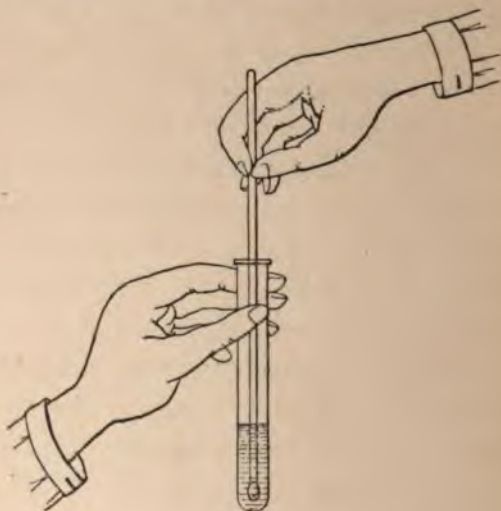

FIG. 62.

shown in Fig. 62) until the last trace of crystals disappears, when the temperature is noted. This operation should be repeated, and second result obtained is the setting point or cold test of the oil. This method of working gives very concordant results, and different operators can easily agree to within half of a degree, but it is most essential that there shall be no moisture or air bubbles in the oil, and, to prevent the latter, it is

necessary that the oil be very carefully and slowly stirred.

For dark-coloured oils, such as pressed and untreated oils, the method is as follows:—A small beaker (about  $1\frac{1}{2}$  inch in diameter by 3 inches deep) is filled to a depth of about 1 inch with the oil to be tested, and is then placed in a freezing mixture and stirred with a thermometer until the surface of the oil becomes

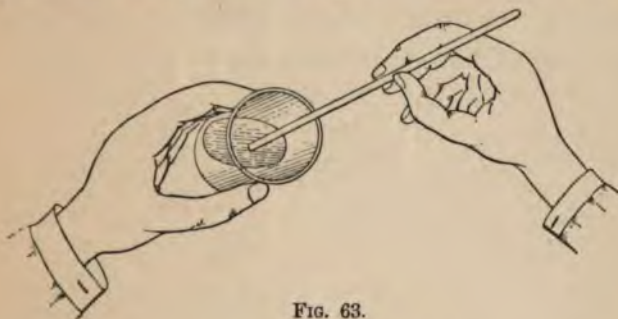

FIG. 63.

“dulled” by crystals of wax. The beaker is then removed from the cooling mixture and held (as shown in Fig. 63) in a good light, and its contents stirred until the last trace of crystals disappears and the surface of the oil is quite bright again. With a little experience and practice, different operators can easily agree in their results to within one degree by this method of working.

#### RELATION BETWEEN COLD TEST AND PERCENTAGE OF WAX.

The author made a large number of determinations of the amount of wax that was contained in oils of different cold tests, and the averages of the results are

given in Table XXVIII. The oil used in making the determinations was an 890 oil of 26° F. cold test, and the wax used in raising the cold test was the wax which belongs to that grade of oil (and which had been removed by pressing the cooled 890 lubricating oil distillate), and had a melting point of 102° F. We see by reference to the table that an oil of 33° cold test contains 1·477 per cent. more wax than an oil of 26° cold test, or that an oil of 39½° cold test contains 0·962 per cent. more wax than an oil of 33° cold test, and so on.

TABLE XXVIII.

Cold Test.	Per Cent. by Weight of Wax.	Cold Test.	Per Cent. by Weight of Wax.
° F.		° F.	
26	0·000 *	39½	2·439
29	0·497	41½	2·912
30	0·695	43	3·381
31½	0·990	45	3·846
33	1·477	47	4·306
36½	1·970		

\* It must not be supposed that 26° cold-test oil contains no wax, as that is not the case; but a certain cold test had to be taken for a starting point, and 26° was the lowest that could conveniently be obtained, and was therefore adopted as the starting point.

#### FLASH POINT.

There are too many methods of taking the flash point of oils to allow of their all being referred to here, and therefore only the generally adopted methods will receive notice.

In determining the flash point of burning, and other

comparatively low-flashing oils, an apparatus designed by Abel, and known as the "closed test" is almost universally used. Abel's apparatus consists, in general, of a small metal cup (provided with a cover) which fits into an air bath surrounded by a water bath. The water in the water bath is heated to a certain\* temperature and imparts its heat to the air (contained in the air bath), and the latter imparts heat to the oil. The oil is thus heated very slowly (the prescribed rate being 1° F. per minute), and at every rise of one degree in temperature of the oil, a small slide fitted to the cover of the oil cup is pulled on one side, and a flame of the size of a bead is admitted to a point just below the opening in the cover. If the oil is sufficiently hot the flame will cause a slight flash to cross the surface of the oil, and the temperature at which that takes place is the flash point of the oil by the Abel or closed test.

In determining the flash point of lubricating or high flashing oils, the "open" test is usually employed.

In order to make this test it is only necessary to have an open metal † cup about 2 inches in diameter by 2 inches deep. This cup is filled to within half an inch of the top with the oil, and a thermometer having been suspended in it, a small argand flame is applied underneath. The oil must be heated very slowly, and about fifteen to twenty minutes should be taken in raising the temperature to, say, 300° F., also, it is absolutely neces-

\* If the flash point of the oil is very high, the temperature of the water must be higher than for low-flash point oils.

† If there are any joints they must be brazed, as ordinary solder will melt.



sary that there shall be no draught whatever near the cup, and the latter should be placed in a corner shaded from direct light, so that the flash may be easily seen when a bead flame is passed across the top of the cup at a distance of one-sixteenth of an inch above the surface of the oil.

### VISCOSITY.

The viscosity represents the amount of "body" or viscosness that an oil has, and it is determined by the use of different apparatuses in different countries. B. Redwood's viscometer is the English standard instrument, while G. M. Saybolt's is the American, and Engler's the German standard.

The method of determining the viscosity by any of the above instruments is essentially the same, and consists in noting the length of time that a given quantity of oil at a certain standard temperature takes to run through a small orifice at the bottom of the instrument.

The temperature at which the viscosity of an ordinary lubricating oil is determined has been fixed by usage at 70° F., and the reason why that temperature has been adopted as a standard is because it is the one most easily obtained and held at all seasons of the year. It is important that the temperature of the room should be at as near 70° F. as possible, because, notwithstanding that the instruments are surrounded by a water bath, the results are considerably affected by any great variation in the temperature of the atmosphere above or below the standard temperature.

General oils of the same specific gravity often vary in viscosity, and, as the higher the viscosity the quantity of oil usually is necessary to lubricate a piece of machinery, it is to the interest of the owner to buy his oil by the viscosity test rather than by the specific gravity—which latter test is, at present, the one an oil is usually valued by. However, it would be unwise to give preference to an oil on the strength of the viscosity only, as the viscosity is considerably affected by the cold test of the oil, and therefore the cold test should always be considered in connection with the viscosity. By referring to Table XXIX, the relation between cold test and viscosity will be plainly seen, and it will be noticed that the heavier oils are affected to a greater extent per degree of cold test than the thinner oils.

TABLE XXIX.

Sp. Gr. Oil.		885 Sp. Gr. Oil.		890 Sp. Gr. Oil.	
Sp. Gr. Oil.	Viscosity.	Cold Test.	Viscosity.	Cold Test.	Viscosity.
0.885	223	27°	260	27°	279
0.890	229	32°	271	33°	297
0.895	234	34½°	285	36°	317
0.900	241	39°	301	40°	345
0.905	247	42½°	317	42°	364

The higher the cold test the more wax there is present in the oil, and, as wax is an exceedingly bad lubricant, it stands to reason that if there are two oils

of the same viscosity to choose from and the cold test in one case is five or ten degrees higher than the other the lower cold test oil should be selected.

Numerous machines have been designed for practically testing the lubricating qualities of an oil, but the results obtained from such machines are of little or no value to the user of lubricating oils for the reason that the bearings, &c., in those machines are as perfect as it is possible to make them, whereas the bearings in use in mills and shops generally have some little defects, and an oil that would answer well for lubricating one journal might be useless for another, and therefore if the user would try three or four different grades of oil, and having determined which one gives the best results with his machinery, would have the cold test and viscosity of the oil of his choice carefully determined and arranged that future deliveries of oil corresponded with these tests, he would save oil and wear and tear to his machinery.

TABLE XXX.

Name of Oil.	Specific Gravity.	Viscosity (by B. Redwood's Apparatus).		
		At 70° F.	At 100° F.	At 130° F.
885 mineral oil . . . .	886	seconds. 78	seconds. 43	seconds. 32
890 " " . . . .	890	155	69	47
Cottonseed oil . . . .	916	377	193	87
Thickened ditto . . . .	967	4540	1550	463
Lard oil . . . . .	922	315	163	77
Tallow oil. . . . .	917	390	196	88

An oil that will act as a first class lubricant on cool journals is often perfectly useless for hot work, such as lubricating steam cylinders, and Table XXX. has been prepared so that an idea of the variation in viscosity due to changes in temperature may be formed.

#### MELTING POINT.

The melting point of a wax is the temperature at which the wax changes from the molten to the solidified condition, and the determination of that temperature is generally made by taking advantage of the latent heat of solidification in the following manner. An ounce or so of the melted wax is poured into a glass or metal vessel and slowly stirred with a thermometer; the temperature of the wax will constantly and gradually diminish until the wax commences to solidify, and shortly after solidification has commenced it will be noticed that the temperature will remain perfectly stationary for the space of a minute or two, and that temperature is recorded as the melting point of the wax. After the wax has given up its latent heat of solidification the temperature again starts to fall and continues falling until the temperature of the surrounding atmosphere is reached. The same results are obtained whether the vessel containing the wax is moved while the thermometer remains stationary, or the thermometer is moved and the vessel is stationary. This method has been in use in England for the past fifteen or twenty years with the greatest possible success, and melting points determined by it do not usually vary more than a quarter of a degree F. between different operators.

In determining the melting point of stearine it will be noticed that the temperature will remain stationary for a short time and then start to rise, and after rising anywhere from  $3^{\circ}$  to  $15^{\circ}$  F. (according to the grade of the stearine) will remain stationary for some time before starting to fall again. The melting point in this case is the temperature recorded after the mercury column has finished *rising*.

In the manufacturing business it is constantly necessary to mix waxes of different melting points in order to supply the special melting point waxes often called for. There is no difficulty whatever in calculating the quantities of any two or more waxes of known melting points necessary to give a wax of any intermediate point, and the calculations are made as follows:—

Suppose 1000 lbs. of  $116\frac{1}{2}^{\circ}$  melting point wax were wanted, and that the melting points of the waxes in stock were 120 and 115. Then,  $116\frac{1}{2} - 115 = 1\frac{1}{2}$ , and  $120 - 116\frac{1}{2} = 3\frac{1}{2}$ , it will be necessary to mix the waxes in the proportion of  $1\frac{1}{2}$  parts of 120 and  $3\frac{1}{2}$  parts 115 melting point, or, 300 lbs. of the former to 700 lbs. of the latter.

In the manufacture of candles stearine is often, and, in fact, generally, used in admixture with the wax, but, in this case, the melting point of the mixture of wax and stearine cannot be calculated, as stearine has the peculiar property of lowering the melting point of the mixture to, in certain cases, even below the melting point of either of the ingredients used. Therefore Tables XXXI. to XXXVI. have been prepared (and are the results of many careful determinations) in order to

enable those who require mixtures of wax and stearine of certain melting points to make the mixtures without going through the laborious process of determining the necessary proportions by making up "trial mixtures."

TABLE XXXI.

Melting Point of Wax used = 102° F.  
 " " Stearine used = 121° F.

Percentage of		Melting Point.	Percentage of		Melting Point.
Wax.	Stearine.		Wax.	Stearine.	
		° F.			° F.
90	10	100	40	60	111
80	20	98½	30	70	113½
70	30	100	20	80	117½
60	40	104½	10	90	119
50	50	110½			

TABLE XXXII.

Melting Point of Wax used = 120° F.  
 " " Stearine used = 123° F.

Percentage of		Melting Point.	Percentage of		Melting Point.
Wax.	Stearine.		Wax.	Stearine.	
		° F.			° F.
90	10	118	40	60	109
80	20	116½	30	70	113
70	30	114	20	80	118½
60	40	112	10	90	119½
50	50	110			

TABLE XXXIII.

Melting Point of Wax used = 120½° F.  
 " " Stearine used = 129¼° F.

Percentage of		Melting Point.	Percentage of		Melting Point.
Wax.	Stearine.		Wax.	Stearine.	
		° F.			° F.
90	10	118½	40	60	118¾
80	20	116¾	30	70	122
70	30	114½	20	80	124½
60	40	112¼	10	90	127
50	50	113			

TABLE XXXIV.

Melting Point of Wax used = 125° F.  
 " " Stearine used = 121° F.

Percentage of		Melting Point.	Percentage of		Melting Point.
Wax.	Stearine.		Wax.	Stearine.	
		° F.			° F.
90	10	123	40	60	111
80	20	121	30	70	107
70	30	119	20	80	114
60	40	117½	10	90	117
50	50	114			

MELTING POINT.

227

TABLE XXXV.

Melting Point of Wax used = 130° F.  
 " " Stearine used = 121° F.

Percentage of		Melting Point.	Percentage of		Melting Point.
Wax.	Stearine.		Wax.	Stearine.	
		° F.			° F.
90	10	128	40	60	114
80	20	125½	30	70	109
70	30	123	20	80	115½
60	40	121	10	90	118
50	50	118½			

TABLE XXXVI.

Melting Point of Wax used = 132¼° F.  
 " " Stearine used = 129¼° F.

Percentage of		Melting Point.	Percentage of		Melting Point.
Wax.	Stearine.		Wax.	Stearine.	
		° F.			° F.
90	10	130½	40	60	117¾
80	20	128½	30	70	119½
70	30	126½	20	80	125¼
60	40	124¼	10	90	127½
50	50	121			



## OIL IN WAX.

It is practically impossible to press a cooled mixture of oil and wax so as to obtain a crude scale that is entirely free from oil, and as a consumer does not wish to buy oil at the price of wax, he is naturally desirous of knowing how much oil the crude wax he is buying contains.

The percentage of oil in wax is determined by taking 500 grains weight of the powdered wax at a temperature of 60° F. and (after placing it between two pieces of linen and four pieces of blotting paper and enclosing the whole in an iron ring (5½ inches inside diameter) into which a piston snugly fits, subjecting it to a pressure of 5 cwt. (560 lbs.) per square inch for a space of five minutes. The loss that the wax sustains by being subjected to this treatment is called "oil."

Some crude waxes contain a certain amount of dirt and water.

## DIRT IN WAX.

The percentage of dirt should be determined by melting a pound weight of the wax in a large beaker and then adding twice its volume of 725 specific gravity naphtha. The naphtha solution is then to be filtered through a tared paper filter, the beaker thoroughly washed with fresh supplies of naphtha and the washing thrown into the filter, and, finally, the filter and any residue that remains in it are to be washed four or five times with the 720 naphtha, and then given a last wash with gasoline. After being dried for three or four hours

at a temperature of 200 F. the filter must be allowed to cool and then be re-weighed; any increase in weight represents the quantity of dirt present in the wax.

#### WATER IN WAX.

In order to determine the per cent. of water, one pound of the wax should be melted and poured into a conical shaped copper still, and the top of the still should be closed by a cork to which is fitted a bent glass delivery tube about 2 feet long. The still is then gently heated until nearly all the water has distilled off, and then the temperature should be raised to about 250° F. and maintained at that until the water ceases to drop from the end of the delivery tube. The water having been caught in a tared beaker is weighed and the percentage calculated.

A suitable still for this purpose is one made of  $\frac{1}{8}$ -inch thick copper, having a diameter of 7 inches at the bottom and 1 inch at the top, and a perpendicular height of 9 inches. It is better to have the bottom dished  $\frac{1}{4}$  or  $\frac{1}{2}$  an inch.

#### BURNING OIL.

The burning oil products should of course be regularly tested photometrically, and, in the event of an outsider's oil being sent for duplication, it is also necessary to determine, besides the specific gravity, flash, &c., whether the oil has been finished with a distillation or treatment. This determination is usually easily made by simply placing one's ear close to the side of the

burner while the oil is burning in a lamp, and if a slight crackling sound is heard it is a sure indication that the oil has been finished by a treatment, whereas if no such noise is heard it is an indication that the oil was finished with a distillation.

The comparative illuminating power of various fractions from the third stage oil stills is given in Table XXXVII.

TABLE XXXVII.

Specific Gravity of Fraction.	Illuminating Power in Standard Candles.	Specific Gravity of Fraction.	Illuminating Power in Standard Candles.
From light oil stills.			
761	12·20 *	816	16·50
764	20·70	818	16·55
		From heavy oil stills.	
768	19·90	801	19·22
774	19·25	805	20·24
779	18·94	814	18·41
784	20·00	818	16·70
791	18·90	823	16·40
794	19·40	830	16·54
798	18·60	835	15·80
804	19·40	840	†
811	17·00		

\* Too light to burn well.

† Would not burn in lamp.

#### COMPOUNDED OR MIXED OILS.

Both burning and lubricating oils of mineral origin are often mixed or "compounded" with "fatty" (vegetable or animal) oils, rosin oils, mineral compounds and sometimes with paraffin wax.

*Wax Admixture.*

The presence of wax is easily detected and the quantity estimated by cooling and pressing a small quantity of the oil.

*Fatty Oil Admixture.*

Fatty oils are readily detected by boiling quarter of an ounce or so of the oil with alcoholic soda\* for twenty to thirty seconds in a large test tube. If as little as 2 per cent. of fatty oil be present, the mixture will become a gelatinous mass on cooling; and if larger percentages are present the mixture will become gelatinous or even solid while hot.

When the presence of a fatty oil has been detected, its quantitative determination may be quickly made by taking 50 grains weight of the oil, mixing it with about 500 grains of silver sand, and then adding an excess of alcoholic soda and evaporating, with constant stirring, over a water bath until all smell of alcohol has been discharged. The mass is then to be thrown into a filter and washed with small successive quantities of gasoline, ether or other *very* volatile solvent, until a small drop of the filtrate ceases to leave any oil stain after being placed on a watch-glass and evaporated. The soap produced by the saponification of the fatty oil by the soda is unaffected by the gasoline, &c., while the mineral oil is quickly washed from the sand and finely divided particles of soap, and, the total filtrates having

\* Saturated solution of caustic soda in absolute alcohol.

been placed in a tared flask and the solvent (gasoline, &c.) slowly evaporated, the amount of mineral oil is determined by weighing, and the difference between its weight and the weight of the quantity operated on gives the amount of fatty oil.

The reason for adding sand to the original oil is to prevent the soap from forming in a mass, and the constant stirring of the oil, sand and alcoholic soda during evaporation helps to ensure the particles of soap being in a fine state of division.

#### *Rosin Oil Admixture.*

The presence of rosin oil is best detected by vigorously rubbing a small quantity of the oil between the palms of the hands and then quickly smelling it.

#### *Mineral Compounds Admixture.*

In order to determine whether a mineral compound is present in the oil, it is necessary to take a small quantity (about 25 to 30 grains) of the oil and heat it in a platinum crucible until the whole of the volatile matter has been burnt and the resulting coke consumed. If any ash remains it is undoubtedly the mineral adulterant that the oil has been "thickened" with. The mineral "thickeners" that are most commonly used are the stearates or oleates of alumina and lead, but the nature of the mineral can, of course, be easily determined by testing the above ash.

## TESTING AMMONIA WATER.

The ammonia water from the retorts, and also the spent water from the ammonia stills should be daily, or even more frequently, tested.

In order to be able to make the determination of the amount of ammonia contained in these waters quickly and accurately, *methol orange* should be used as an indicator, because it is neither affected by the carbonic acid or sulphuretted hydrogen contained in the water. The strength of the water from the old vertical and the Henderson retorts could be accurately determined by merely adding a few drops of methol orange to 50 c.c. of the water and titrating with a standard normal solution of sulphuric acid; but, when the Young and Beilby retorts came into use, it was found that the actual yield of sulphate of ammonia was far short of what the laboratory determinations showed it ought to be. Careful investigations disclosed the fact that the Young and Beilby ammonia water was rich in oily bases, and the standard acid being neutralised by these bases caused the laboratory determinations to point to the presence of more ammonia than was actually present in the water.

As the bases were present as carbonates and sulphides they could not be removed until they were set free, and therefore it was necessary to add sufficient soda to neutralise the carbonic and sulphurous acids that held the bases in combination, in order to set the latter free, consequently the method adopted for testing Young and Beilby ammonia waters is to

Take 100 c.c. of the water, and add 25 c.c. of a standard normal caustic soda solution, and 50 c.c. of refined naphtha, and shake the mixture vigorously for three or four minutes. This treatment results in the bases being set free by the soda, and taken into solution by the naphtha, and after the mixture has settled for five or ten minutes, 10 c.c. of the water are drawn off and titrated with acid as above—allowance being made, of course, for the standard soda solution that was added to the water.

Testing the water in this manner resulted in the usual agreement between laboratory and works—results which always differ to the extent of half a pound of sulphate of ammonia per ton of shale—that amount being the manufacturing or working loss.

#### TESTING SULPHATE OF AMMONIA.

Commercial sulphate of ammonia usually contains 24 per cent. of ammonia ( $NH_3$ ) as against the theoretical possibility of  $25\frac{3}{4}$  per cent.

The strength is determined by placing, say, one gramme of the sulphate in a glass flask fitted with a safety funnel and a delivery tube, which latter dips beneath the surface of a standard sulphuric acid solution contained in a conical beaker. 50 c.c. of water and 25 c.c. of a  $64^\circ$  Tw. caustic soda solution are now run into the flask through the funnel, and heat is applied. After the contents of the flask have been gently boiling for half an hour, the cork holding the funnel and delivery tube is loosened sufficiently to allow a little

of the steam to escape against a piece of moistened turmeric paper, and if the latter turns brown the boiling is continued until the steam causes no discoloration when brought in contact with the moistened paper, and which is evidence that the whole of the ammonia has been driven over into the acid. The amount of acid neutralised is determined by titration with a normal soda solution, and the percentage of ammonia contained in the sulphate is calculated from the results.

SULPHATE OF AMMONIA LIQUOR.

The variation in gravity of sulphate of ammonia liquor due to temperature is given in Table XXXVIII.

TABLE XXXVIII.

Temperature, Degrees Fahr.	Gravity in Degrees Twaddell.	Temperature, Degrees Fahr.	Gravity in Degrees Twaddell.
40	48 $\frac{1}{4}$	130	43 $\frac{3}{4}$
50	47 $\frac{3}{4}$	140	43
60	47 $\frac{1}{4}$	150	42 $\frac{1}{2}$
70	46 $\frac{3}{4}$	160	42
80	46 $\frac{1}{4}$	170	41 $\frac{1}{4}$
90	46	180	40 $\frac{1}{2}$
100	45 $\frac{1}{2}$	190	40
110	44 $\frac{3}{4}$	200	39 $\frac{1}{2}$
120	44 $\frac{1}{4}$		



## DETERMINATION OF BOILING POINTS.

The boiling point of an oil is the temperature at which the vapours form and pass off to the condenser. As the temperature of the vapours continually rise as the distillation progresses, and as the boiling point can only be determined by noting the temperature at the moment that the first drop of distillate forms, it is obvious that any variation in the distance between the outlet of the still and the point where the first drop of distillate can be seen, will result in a corresponding variation in the boiling point noted. For instance, if the distance between the still and the point where the distillate can first be seen is 6 inches in one case, and 24 inches in another, it is plain that by the time the distillate has travelled the distance of 24 inches the temperature of the vapours in the still will be higher

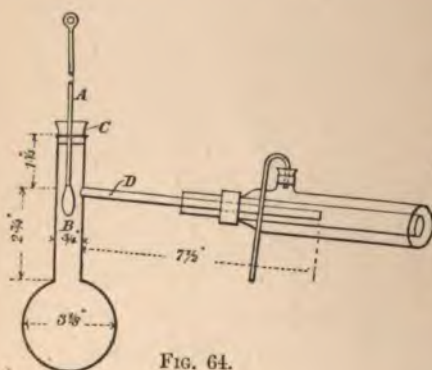

FIG. 64.

than when the distillate had travelled only 6 inches; and, for that reason, it is necessary that a standard size of still and connections should be adopted. The Lighthouse Commissioners use the form and size of glass

still shown in Fig. 64, in determining the boiling point of oils supplied them—these stills can be easily made or supplied by dealers in scientific glass instruments.

The thermometer A (Fig. 64) is fastened in the fractionating tube B by the cork C, so that its bulb is exactly in the centre of the tube B, and so, also, that the top of the bulb is level with the top of the delivery tube D. The delivery tube D is inserted into a glass Liebig's condenser, and secured by a cork so that  $1\frac{1}{2}$  inch of the tube projects past the cork.

After the still has been half filled, heat is to be applied gently, but must be sufficient to cause a thorough ebullition, and as soon as the first drop of distillate is seen to fall from the end of the tube D the temperature is noted, and that temperature is the boiling point of the oil.

In determining boiling points, as also in fractionating oils, the heat applied to the still should only be sufficient to cause the distillate to *drop* from the condenser, and should never be so great as to cause a distillate to *run* in either a continuous or intermittent *stream*.

#### PURIFICATION OF CRUDE OIL.

The company that produces its own, as well as the company that buys its crude oil, should have frequent laboratory purifications made of the oil to see whether, in one case, the shale is still yielding the same quality of oil, or, in the other case, the supply of purchased crude oil is keeping up to the contract standard.

The apparatus necessary for this work is inexpensive and consists of:—

A copper still (Fig. 65).

A straight tube condenser.

An inverted leg-vise for "hard" pressing wax.

A "soft" wax press (Fig. 63).

A set of metric measuring flasks, and a few glass stoppered bottles, beakers, &c.

The still shown in Fig. 65 consists of the body A

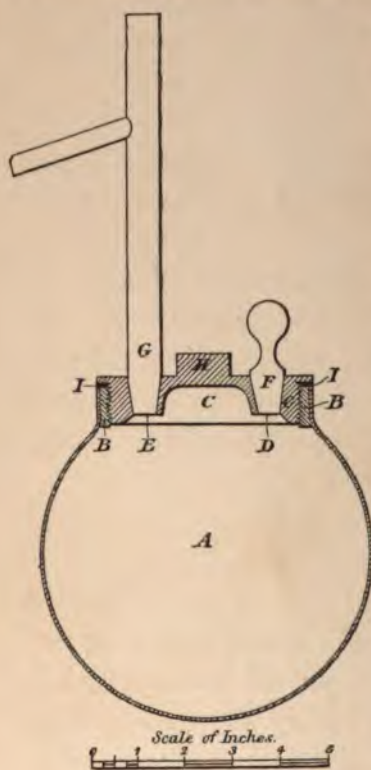

FIG. 65.

is brazed the threaded ring B. The cover C, which is threaded so as to screw into B, is provided with the two slightly tapered holes D and E, which latter must be carefully reamed out so that the taper exactly corresponds with the taper of the brass plug F, and brass fractionation tube G. The centre of the cover should be provided with the square projection H, so that, after the still has been cleaned and the asbestos gasket I put in place, the cover can be tightly screwed down by applying a wrench to the projection on the cover,

while the body of the still is firmly grasped in both hands by an assistant. The fractionation tube having been firmly pressed into its tapered hole, and the still having been charged through the plug hole, and the plug

inserted, is then placed in a suitable iron ring stand, and the distillation effected by means of either a large (1-inch diameter) Bunsen burner, or a 3-inch solid flame Fletcher burner.

The condenser may be conveniently made on the principle of an ordinary Liebig's condenser, the water space being formed by a galvanised iron jacket surrounding a  $\frac{3}{4}$ -inch copper pipe 3 feet long. About 6 inches of this pipe should project past each end of the jacket.

The inverted vise is used by wrapping up the material to be pressed in a piece of linen and then in canvas, and having placed it between two iron plates (6 inches long by 4 inches wide and  $\frac{3}{8}$  inch thick) the whole is held between the extended jaws of the vise, and then the latter slowly brought to bear on the plates. The expressed oil is caught in a tray or other suitable vessel placed directly under, and as near to the plates as possible.

The "soft" wax press is intended for the purpose of enabling oils of low cold test to be obtained. Its construction is shown in Fig. 66, and the only parts that need special explanation are the plates A and B, which are best constructed of cast iron and are hollow. The space between the two sides *a* and *b* is shown in the figure as being  $1\frac{1}{8}$  inch, but if this were reduced to  $\frac{3}{4}$  of an inch, and the remaining  $\frac{3}{8}$  of an inch added to the thickness of the sides, it would be an improvement. The lugs *c* enable the plates to slide on the press-frame rods, but as it is better for the plate A to be immovable, it is secured in its place by the screw *d*.



can be obtained at a reasonable cost, and the contents of one cylinder would be sufficient to enable many cold pressings being made.

As the temperature at which the crude oil is measured should be about  $100^{\circ}$  to  $150^{\circ}$  F., and as the temperature of the various products when measured ranges from  $50^{\circ}$  up to  $150^{\circ}$  F., it is necessary that allowances in volume for variations in temperature be made in all cases. The coefficient of expansion is not exactly the same for both light and heavy oils, but the difference is so small that an allowance of 1 per cent. in volume for every  $25^{\circ}$  F., is sufficiently correct for practical purposes in all cases.

Supposing the still to be ready for charging, and that the temperature of the litre (1000 c.c.) of crude oil is  $145^{\circ}$  F., then:— $145^{\circ} - 60^{\circ} = 85^{\circ}$  above the standard temperature, and  $85 \div 25 = 3.4$  per cent. more oil must be added, or, in other words, the still must be charged with 1034 c.c. of crude oil at a temperature of  $145^{\circ}$  F., in order to equal 1000 c.c. at  $60^{\circ}$  F.

The distillate should run from the condenser in a constant but very small stream, and when 75 per cent. of the oil has distilled off, the water in the condenser should be allowed to heat up. When the distillate reaches an almost black-red colour the supply of heat should be shut off, and any distillate from that time be collected separately and designated chrysene.

The main portion of the distillate (which from a good crude oil will be equal to about 94 to 95 per cent. of the crude oil charged into the still) having been measured (and allowance for temperature made) and its

specific gravity having been determined, it is placed in a bottle, and after being cooled to about 100° to 120° F. is to be shaken for fifteen minutes with 5 per cent. of 148° Tw. acid. It must then be allowed to settle for eight hours at a temperature of 100° F., and having been decanted into a clean bottle (so that all the oil and no acid tar is obtained) it is to be shaken for five minutes with an excess of 65° Tw. caustic soda solution and settled for about two hours at a temperature of about 100° F. The clear oil having been thoroughly separated from any soda tar is now to be measured, and, its specific gravity having been determined, charged into a clean still.

In making the following (second) distillation it is customary to introduce steam into the still by replacing the plug (F, Fig. 65) by a cork through which passes a piece of brass tubing that is continued to the bottom of the still, and is connected on the upper end by a piece of rubber tubing to a flask or can of boiling water. The rubber tube should have a  $\frac{1}{32}$ -inch hole in its side, through which it can draw air in the event of the supply of heat to the steam generator being accidentally withdrawn. This hole will result in more or less escape of steam, but if it is not provided and the steam generator should by some unforeseen cause cool down, it will result in a vacuum that will draw the hot oil from the still over into the steam generator, and if any water is left in the latter it will be liable to cause a violent explosion, not to speak of spoiling the work that has been so far accomplished.

The distillate from the start of the distillation until

the bulk specific gravity reaches 750 constitutes naphtha, and its volume generally ranges between 1 and 5 per cent. on the crude oil. After the naphtha is off, another receptacle is placed to receive the distillate, and the steam should then be admitted to the still. This second fraction of the distillate is 1st stage burning oil, and should be run until a drop of the distillate from the condenser worm or pipe shows wax when placed on a cool (35° F.) surface, and as soon as that point is reached the distillate is to be caught in another receptacle, which must be capable of holding the rest of the distillate. The third fraction is "heavy oil," and consists of all the oil from the last named point, down to the coking of the still.

After all the water has been separated, the two last fractions are to be carefully measured and, after their specific gravities have been determined, the "heavy oil" fraction is to be placed on one side while the burning oil fraction is to be treated with 2 per cent. of 170° Tw. acid and an excess of 65° Tw. caustic soda, and then, after the determination of the specific gravity and volume, it is to be subjected to another distillation aided by steam.

This time the distillate is to be taken off in two fractions; the first consists of the oil from the start until the bulk specific gravity reaches 810, or, if the oil taken from the condenser end and cooled (as above) shows wax before the bulk specific gravity is 810, the fraction consists of the oil from the start until the first trace of wax begins to show. In either case, this fraction is termed "burning oil." The second fraction



is the oil run from the above point, to the end of the distillation, and is termed "heavy oil."

The two fractions are to be measured, &c., and the burning oil one placed on one side while the other is to be mixed with the heavy oil from the previous distillation, and the mixture allowed to cool slowly to a temperature of about 50° F.

Supposing the mixed heavy oils have been cooled over night, the now solid mass is cut into pieces of a suitable size and pressed in the "vise." In doing this work it is unwise to attempt to press too much at a time, and the mass should rather be pressed in four or five separate portions until almost free from oil, and then these pressed portions should be mixed and subjected as one to a final pressure for five or six hours. If this pressing is carefully done a final pressure of the equivalent of 140 lbs. hung on the end of the vise handle (3 feet long) can be exerted without bursting the cloth containing the wax.

This operation being completed and the "hard" wax placed on one side for the present, the expressed oil or "hard squeezings" are measured, &c., and then cooled to 15° to 20° F. and pressed in the soft wax press. The "soft" wax resulting from this pressing is placed on one side, and the "soft" squeezings, after being heated to 70° F., measured, &c., are placed in the still together with about 200 grains of solid caustic soda, and distilled with the aid of steam, and the distillate should be caught in 50 c.c. fractions and the order of the fractions carefully marked on the receptacles.

Supposing that the burning oil from the previous

distillation had only been run to a bulk specific gravity of 803, it will now be necessary to add fractions (starting with No. 1) from this last distillation until the bulk specific gravity of the burning oil has been increased to 810. That having been done, it is necessary to now take the last fraction and (working backwards) add the preceding fraction to it, and so on until an oil of 888 bulk specific gravity is obtained; the resulting oil will be untreated lubricating oil. Should any fractions or part of a fraction be left over it must be measured, specific gravity taken if the quantity is large enough, and be reported as "Intermediate" oil.

The 810 specific gravity burning oil is now to be treated with 3 per cent. of 170° Tw. acid and 4° Tw. caustic soda, and then constitutes refined burning oil.

The untreated lubricating oil is treated with 3 per cent. of 170° Tw. acid and 4° Tw. caustic soda, and then reported as Finished Lubricating Oil.

The waxes from the "vise" and "soft wax press" are weighed (separately) and the weights divided by .81 (to convert them into volume), and the melting points and percentage of oil having been determined, the waxes are respectively reported as Hard and Soft Crude Scale.

#### REPORTING RESULTS.

In calculating the percentages, &c., prior to filling up a report, it is always necessary to make a few other calculations also, for the reason that in a laboratory purification it is impossible to press the heavy oils, &c., without losing a comparatively large amount of oil due

to absorption by the press cloths, &c. &c. On the working scale this loss is small owing to the cloths, &c., being in constant use, and only absorbing a very small amount of oil compared with the amount that is passed through them. For laboratory work it is usual to argue that no oil is lost by the pressing process, and therefore we will suppose that the percentage of mixed heavy oils before pressing was 45, and that after pressing 7 per cent. of hard wax and 34 per cent. of hard squeezings were obtained. This would give a total of  $(34 + 7 =)$  41 per cent. as against 45 per cent., or a loss of 4 per cent.

The 34 per cent. of hard squeezings after being soft pressed, we will suppose, gave 4 per cent. of soft wax and 28 per cent. of soft squeezings, or a loss of 2 per cent.

The above figures show that the hard squeezings should have been equal to  $(45 - 7 =)$  38 per cent., and therefore if 34 per cent. gives 4 per cent. of soft wax, 38 per cent. would give  $(34 : 38 :: 4 =)$  4.47 per cent. of wax. The percentage of soft squeezings obtained was 28, but 4 (= per cent. of soft wax) deducted from 34 (= per cent. of hard squeezings) gives 30 per cent. if no loss takes place, and therefore if 34 per cent. gives 30 per cent., 38 per cent. would give  $(34 : 38 :: 30 =)$  33.53 per cent. of soft squeezings. These calculations must be carried out for the squeezings treatment, and for the burning oil, intermediate oil and lubricating oil from the last distillation.

The following is a most convenient way of reporting the results of a laboratory purification.

REPORTING RESULTS.

247

Purification of.....crude oil  
 received from.....

F- e	Grade of Oil.	Sp. Gr. at 60° F.	Per cent. by vol- ume.
	Crude oil . . . . .		
	Once-run oil . . . . .		
	"    "    after treatment with 5 per cent. acid (148° Tw.) . . . . .		
	No. 3 oil, after treatment with excess of caustic soda (65° Tw.) . . . . .		
	No. 4 oil, after distillation :—		
	Naphtha . . . . .		
	Burning oil (1st stage) . . . . .		
	Heavy oil . . . . .		
	Burning oil :—		
	1st stage burning oil (No. 6), after treatment, 2 per cent. acid (170° Tw.), and excess caustic soda (65° Tw.) . . . . .		
	No. 8, after distillation :—		
	Burning oil . . . . .		
	Heavy oil . . . . .		
	Burning oils (Nos. 9 and 16), after treatment, 3 per cent. acid (170° Tw.) and excess caustic soda (4° Tw.) . . . . .		
	Heavy oils (Nos. 7 and 10) cooled to 50° F. and pressed :—		
	Hard crude wax, M.P. . . . ., containing . . . per cent. of oil . . . . .		
	Hard squeezings . . . . .		
	No. 13 cooled to 20° F. and pressed :—		
	Soft crude wax, M.P. . . . ., containing . . . per cent. of oil		
	Soft squeezings . . . . .		
	No. 15 oil after distillation off caustic soda :—		
	Burning oil . . . . .		
	Intermediate oil . . . . .		
	Untreated lubricating oil . . . . .		
	No. 18, after treatment, 3 per cent. acid (170° Tw.) } caustic soda (4° Tw.) . . . . . }		
	<b>FINISHED PRODUCTS.</b>		
	Naphtha (No. 5) . . . . .		
	Burning oil (No. 11) . . . . .		
	Intermediate oil (No. 17) . . . . .		
	Hard and soft crude wax (Nos. 12 and 14) M.P. . . . . } (calculated) . . . . . }		
	Finished lubricating oil No. 19) {cold test . . . . . } {viscosity . . . . . }		
	Total . . . . .		

Signature.....

Date.....

DISTILLATION *versus* TREATMENT.

It will be remembered that it was stated under the heading "Refining" that the crude oil purification started with a treatment, gave a lower yield and no better quality products than a purification started with a distillation. The truth of that statement can be seen by referring to Table XXXIX., in which is also shown the result of distilling the crude oil off caustic soda.

TABLE XXXIX.

Finished Product.	Purification Started.					
	By Distillation in usual manner.		By an Acid and Soda treat- ment.		By Distillation off Solid Caustic Soda.	
	Sp. Gr.	Percent.	Sp. Gr.	Percent.	Sp. Gr.	Percent.
Naphtha . . . .	Nil	Nil	Nil	Nil	Nil	Nil
Burning oil . . .	811	33·66	811	31·26	811	32·51
Hard and soft waxes .	M.P. 117½°	11·45	M.P. 119¼°	10·30	M.P. 119¼°	11·50
Lubricating oil . .	885	22·02	885	19·12	885	22·52
Intermediate oil . .	858	5·95	861	7·90	852	9·04
Total . . . . .		73·08		68·58		75·57

The distillation off caustic soda not only results in a larger yield of finished products of excellent quality but also allows of the crude oil being directly fractionated in naphtha, burning oil and heavy oil (No. 5, 6 and 7 of the purification Reporting form), and thus does away

with the acid and soda treatments and distillation of the once-run oil. This method of working of course results, by the usual method of recovering soda from coke, in the loss of coke for fuel, but the loss would be small compared with the saving effected by doing away with the once-run oils treatments and distillation, and, besides, there is no reason why a still furnace could not be constructed so as to consume soda coke so that sufficient heat would result to distil the oil, and at the same time the ashes containing the soda could be saved and the soda recovered.

### DIFFERENCE BETWEEN LABORATORY AND WORKS RESULTS.

The yield of finished products obtained on the working scale is usually 3 or 4 per cent. less than that obtained on the laboratory scale, and is due principally to insufficient condensing capacity—whereby a large amount of oil passes into the atmosphere in the form of vapour.

#### *Analysis of Crude Oil Coke.*

The average composition of the coke from the crude oil stills is:—

Carbon . . . . .	97·96 per cent.
Sulphur . . . . .	0·26    "    "
Ash (earthy matters) . . . . .	1·78    "    "
Total . . . . .	100·00    "    "

*Analysis of Gas from Henderson Retorts.*

Specific gravity (air = 1) 0.250.

Composition:—

Olefiant gas	. . .	2.19	per cent.
Marsh "	. . .	34.20	"
Hydrogen	. . .	64.44	"
Total	. . .	100.83	"

*Analysis of Sacking or Canvas used in the Pressing Department.*

Hemp and flax sacking is often adulterated or cheapened by an admixture of Phormium tenax, and, in order to detect the presence of the latter fibre, the warp and the weft of the sacking are separately moistened with chlorine water and then a few drops of aqua ammonia are added. If Phormium tenax is present it will turn a violet red, while the hemp will turn a pale rose-pink and the flax will remain colourless.

## SPECIFIC GRAVITY OF WAXES.

Table XL. gives the specific gravities of different melting point waxes at various temperatures. This table was compiled by the Author, and first published in the 'Journal of the Society of Chemical Industry.'\*

\* Vol. viii. p. 162.

TABLE XL.

Temp. ° F.	Specific Gravity of Molten Waxes.						
	M.P. 108°	M.P. 114°	M.P. 120½°	M.P. 122¼°	M.P. 122¾°	M.P. 128¼°	M.P. 133¾°
160	770·69	771·93	773·91	770·79	770·23	775·73	777·23
155	771·19	773·30	775·31	771·49	771·63	776·53	778·53
150	773·09	774·73	776·57	773·19	772·83	778·03	780·03
145	775·09	776·20	777·77	775·19	774·63	779·73	781·53
140	776·79	777·63	778·47	776·89	776·33	781·33	783·33
135	778·99	779·53	781·47	778·69	778·43	783·03	..
130	780·49	781·13	782·67	780·29	779·73	..	..
125	781·99	783·43	784·41	..	..	..	..
120	783·59	784·73	..	..	..	..	..
115	785·29	..	..	..	..	..	..
Specific Gravity of Solid Waxes.							
	M.P. 106°	M.P. 111½°	M.P. 120½°	M.P. 122¼°	M.P. 125¾°	M.P. 131°	
60	875·25	882·30	898·95	901·05	903·50	908·65	

## CHRYSENE.

The thick, heavy substance that distils over at the finish of the crude, heavy residuums and soda distillations, and which has been previously referred to as chrysene, is a mixture of that substance with heavy oils and tarry matter, and in order to separate the



chrysene the mixture must be treated in the following way.

About 2 or 3 lbs. of the hot 200° F. chrysene (as made at the stills) are poured into about half a gallon of warm 90° to 100° F. refined burning oil, and the mixture thoroughly stirred for five or ten minutes, and then allowed to cool slowly. After about ten to twelve hours the, now, dark-coloured burning oil may be poured off very cautiously so as not to disturb the yellowish-coloured sediment that will be found at the bottom of the vessel. The vessel and its contents having been heated over a steam bath to a temperature of about 200° F., another half gallon of warm burning oil is added, stirred and allowed to cool. When this second lot of burning oil is decanted it will be noticed that it is not nearly so dark in colour as the first lot, and also that the sediment has become more disintegrated and lighter in colour. The washing process must be repeated eight or ten times, or until the decanted burning oil ceases to be discoloured, and when that point is reached the sediment should be thrown into a large funnel lined with a piece of linen, and there washed with three or four successive quantities (of about half a pint each) of refined naphtha, and then, after being allowed to thoroughly drain, it should receive two washings with gasoline. The sediment is now spread on a piece of clean linen and allowed to dry, the resulting dry yellow-coloured powder is pure chrysene.

No particular use has been found for this substance, and it is rather a chemical curiosity than anything else.

## EXTRACTION OF PHENOLS.

The phenols contained in the soda tar resulting from the once-run oil soda treatment, can be extracted and purified by—

First steam about twenty gallons of the tar with open steam for three or four hours and then allow to settle. In about an hour, more or less paraffin oil will have risen to the surface, and after it has been removed the tar is to be made very slightly acid by the cautious addition of weak (40° Tw.) sulphuric acid with constant stirring. Allow this acidulated mixture to settle for eight to ten hours and then skim off the crude phenols (which have come to the top in the form of a black oil) and redissolve them in a slight excess of weak (10° Tw.) caustic soda solution, and heat to 150° F. with open steam. Allow to stand one hour, and remove any traces of paraffin oil that come to the surface, and then acidify with weak acid. This process is repeated until the soda solution of the phenols ceases to give up any paraffin oil, and then the phenols are finally liberated by acidification, and placed in a tightly closed earthen or glass jar, together with a pound or two of coarsely broken fused chloride of calcium. The jar and its contents must now be kept at a temperature of 100° to 120° F. for three or four days, and then the phenols are to be carefully decanted into a dry jar containing a pound of broken fused chloride of calcium, and kept for another three or four days at a temperature of 120° F. or so. The phenols will now be sufficiently free from moisture to enable them to be distilled.

The distillation of the crude phenols must be started very cautiously, as it is practically impossible to entirely free them of moisture, and the presence of very little moisture will cause them to "foam" and boil over. The still should be only  $\frac{1}{8}$ th full, and the heat should be applied so that it takes at least two hours to bring the still's contents to the distilling point; and also the top of the still should be covered with pieces of burning charcoal so as to prevent any moisture from condensing and dropping back amongst the hot phenols. The water that distils over must be carefully separated, and, by distilling slowly, the phenol distillate can be obtained practically free from moisture. This distillate must now be redistilled three or four times off solid caustic soda before it will be sufficiently pure for fractionation.

A glass flask or still, and glass condenser should be used in fractionating the phenols, because the distillate would be more or less discoloured by coming in contact with iron or copper. A glass still similar to Fig. 64 will fill all requirements, and after the distillation has started the distillate is run into 4-oz. bottles — one bottle being provided for each  $10^{\circ}$  of boiling point (i.e. if the distillation started at  $120^{\circ}$ , the first bottle would be marked, and contain the distillate distilling over between  $120^{\circ}$  and  $130^{\circ}$ ). When all the bottles have been filled (by recharging the still a sufficient number of times) they are to be arranged in their order of boiling points, and, the still and condenser having been thoroughly cleaned, the contents of the bottle containing the lowest boiling point fraction is placed in the still

and redistilled. The redistillation will result in a slightly lower boiling point at the start, and a certain amount of residue being left in the still, but only that distillate that comes over between the temperatures designated must be run into the bottle (which latter must have been previously cleaned). The residue left in the still should be placed in a bottle common for all the residues, and then the still is to be charged with the next higher boiling point fraction, and so on until the contents of all the bottles have been redistilled in their proper order.

After the redistillation of the last fraction, the still and condenser must be cleaned and then recharged with the lightest fraction again, and so on until each fraction has been separately redistilled ten to fifteen times, or, until the boiling points are constant (i.e. until the temperatures at the start and the finish of the distillation are the same as the figures on the bottle call for). Each fraction, *as soon as* it has been distilled for the *last* time, should be hermetically sealed in a glass tube, because the oil quickly oxidises and discolours even if placed in corked or glass stoppered bottles.

The tubes should be marked

Normal Phenols.

B.P. ....° to ....°F.

In fractionating an oil it is important that the rate of distillation should be very regular, and, in order to properly regulate it, it is advisable to occasionally count the number of drops per minute or half minute

## EXTRACTION OF OILY BASES.

The preparation of oily bases from the acid tar of the once-run oil treatment is effected by, first of all, steaming 15 to 20 gallons of the tar for five or six hours. The paraffin oil that comes to the surface must be removed and then the acid is to be neutralised by a weak caustic soda solution and allowed to settle at a temperature of about 150° F. until the bases have separated and risen to the surface. This part of the operation can be dispensed with by taking, say, 2 gallons of bases from the alkaline cracker boxes (if recovered acid is used in the sulphate of ammonia manufacture). Whether the crude oily bases are obtained direct from the acid tar or from the cracker box does not alter the treatment to which they must now be subjected, and which consists in redissolving them in a weak sulphuric acid, separating any paraffin oil, and then liberating them again by neutralisation of the acid with weak caustic soda solution. This process should be repeated four or five times, and after the final liberation the bases should be placed in a jar together with 3 or 4 lbs. of coarsely broken caustic soda, and the jar, having been tightly closed, is to be kept at a temperature of 150° for three days, and occasionally well shaken during that time. At the end of the third day the contents of the jar are to be decanted into another jar containing 2 lbs. of broken caustic soda, and then kept at a temperature of 150° for a week, at the end of which time the bases should be sufficiently dry for distillation.

The process now is exactly the same as that adopted

in the case of the phenols. When the fractional distillations are started it will be found that the bases contain more or less moisture, and great care must be exercised in heating the glass still at the start. The bases appear to have a strong affinity for small quantities of moisture, and absorb moisture from the air very rapidly, and it is therefore a good plan to keep a stick of caustic potash or soda in all the receiving bottles for the various fractions, as by so doing the bases are prevented from absorbing as much moisture as they otherwise would.

#### PREPARATION OF NORMAL PARAFFINS.

The normal paraffins are best prepared from 735 specific gravity naphtha by treating the latter in the following way.

Two gallons of naphtha are run into a carboy (A, Fig. 67) which is fitted with a condenser (B) and connection (C) common to the funnel (D) and air inlet pipe (E), and placed in the tub (F). After a supply of cold water has been turned into the condenser jacket and allowed to overflow into the tub F, one quart of a mixture of one part of fuming nitric acid and one part of strong sulphuric acid is poured into the carboy through the funnel D, and, having placed a plug (M) on the funnel, the mixture of acids and naphtha is to be agitated by connecting E with an air blower (Fletcher's foot bellows answer the purpose well). After a few minutes' agitation, the contents of the carboy will commence to heat, and may possibly get sufficiently hot to cause the naphtha to distil, and in that case the agitation

must be stopped. After the action between the acid and naphtha has stopped and the contents of the carboy have cooled down to 70° to 80° F., another quart of the mixed acids is to be poured into the carboy and then agitated and cooled as above. This operation is repeated until  $2\frac{3}{4}$  gallons of the mixed acids have been added, and then a final addition of one quart of sulphuric acid is made, and after thorough agitation the contents of the carboy must be allowed to settle for about ten hours, but the water must not be shut off from the condenser, because if it is, it will result in a considerable loss of light naphtha vapours.



FIG. 67.

The contents of the carboy will separate into three layers; the bottom one will be dark red in colour and have a gravity of about 118° Tw., the middle one will be cherry coloured and have a gravity of about 15° Tw., while the top one will have a reddish colour and specific gravity of about 755. The top layer should be placed in a bottle marked "Impure Normal Paraffins," and after the addition of half a pound of solid caustic soda, should be placed on one side, and occasionally shaken, for two or three days. This soda

treatment will extract the nitro-compounds formed in the previous process. After the oil has been carefully decanted from the soda it must be shaken with successive portions of strong sulphuric acid until the final acid treatment fails to discolour the acid, and when that point is reached we have pure normal paraffins.

TABLE XLI.

Boiling Point.		Specific Gravity.	Boiling Point.		Specific Gravity.
Degrees Centigrade.	Degrees Fahrenheit.		Degrees Centigrade.	Degrees Fahrenheit.	
100-110	212-230	·703	210-215	410-419	·770
110-120	230-248	·709	215-220	419-428	·772
120-125	248-257	·714	220-225	428-437	·773
125-130	257-266	·720	225-230	437-446	·774
130-135	266-275	·728	230-235	446-455	·776
135-140	275-284	·733	235-240	455-464	·778
140-150	284-302	·737	240-245	464-473	·7785
150-160	302-320	·742	245-250	473-482	·7795
160-165	320-329	·747	250-255	482-491	·7815
165-170	329-338	·750	255-260	491-500	·7835
170-175	338-347	·752	260-265	500-509	·7845
175-180	347-356	·753	265-270	509-518	·787
180-185	356-365	·7555	270-275	518-527	·788
185-190	365-374	·7585	275-280	527-536	·790
190-195	374-383	·761	280-290	536-554	·793
195-200	383-392	·765	290-295	554-563	·797
200-205	392-401	·7665	295-300	563-572	·799
205-210	401-410	·7685			



The pure paraffins must be neutralised with a weak solution of caustic soda, settled about ten or fifteen hours, and are then ready for fractionation.

Table XLI. shows the specific gravities of the paraffins after the fractions have been redistilled eight or ten times ; and Table XLII. gives the names, boiling points and chemical formulæ of normal paraffins.

TABLE XLII.

Name.	Boiling Point.	Chemical Formula.
	° C.	
Octane . . . . .	124	$C_8H_{18}$
Nonane . . . . .	132	$C_9H_{20}$
Decane . . . . .	161	$C_{10}H_{22}$
Undecane . . . . .	182	$C_{11}H_{24}$
Dodecane . . . . .	198	$C_{12}H_{26}$
Tridecane . . . . .	217	$C_{13}H_{28}$
Tetradecane . . . . .	238	$C_{14}H_{30}$
Pentadecane . . . . .	258	$C_{15}H_{32}$
Hexadecane . . . . .	278	$C_{16}H_{34}$
Heptadecane . . . . .	298	$C_{17}H_{36}$

TABLE XLIII.

0° Twaddell and 0° Baumé = 1000 specific gravity.

Equivalent of Twaddell Degrees in Baumé Degrees and Specific Gravity.

Twad- dell.	Baumé.	Specific Gravity.	Twad- dell.	Baumé.	Specific Gravity.	Twad- dell.	Baumé.	Specific Gravity.
1	0.7	1005	31	19.3	1155	61	33.7	1305
2	1.4	1010	32	19.8	1160	62	34.2	1310
3	2.1	1015	33	20.3	1165	63	34.6	1315
4	2.7	1020	34	20.9	1170	64	35.0	1320
5	3.4	1025	35	21.4	1175	65	35.4	1325
6	4.1	1030	36	22.0	1180	66	35.8	1330
7	4.7	1035	37	22.5	1185	67	36.2	1335
8	5.4	1040	38	23.0	1190	68	36.6	1340
9	6.0	1045	39	23.5	1195	69	37.0	1345
10	6.7	1050	40	24.0	1200	70	37.4	1350
11	7.4	1055	41	24.5	1205	71	37.8	1355
12	8.0	1060	42	25.0	1210	72	38.2	1360
13	8.7	1065	43	25.5	1215	73	38.6	1365
14	9.4	1070	44	26.0	1220	74	39.0	1370
15	10.0	1075	45	26.4	1225	75	39.4	1375
16	10.6	1080	46	26.9	1230	76	39.8	1380
17	11.2	1085	47	27.4	1235	77	40.1	1385
18	11.9	1090	48	27.9	1240	78	40.5	1390
19	12.4	1095	49	28.4	1245	79	40.8	1395
20	13.0	1100	50	28.8	1250	80	41.2	1400
21	13.6	1105	51	29.3	1255	81	41.6	1405
22	14.2	1110	52	29.7	1260	82	42.0	1410
23	14.9	1115	53	30.2	1265	83	42.3	1415
24	15.4	1120	54	30.6	1270	84	42.7	1420
25	16.0	1125	55	31.1	1275	85	43.1	1425
26	16.5	1130	56	31.5	1280	86	43.4	1430
27	17.1	1135	57	32.0	1285	87	43.8	1435
28	17.7	1140	58	32.4	1290	88	44.1	1440
29	18.3	1145	59	32.8	1295	89	44.4	1445
30	18.8	1150	60	33.3	1300	90	44.8	1450

TABLE XLIII.—*continued.*

0° Twaddell and 0° Baumé = 1000 specific gravity.

Equivalent of Twaddell Degrees in Baumé Degrees and Specific Gravity.								
Twad- dell.	Baumé.	Specific Gravity.	Twad- dell.	Baumé.	Specific Gravity.	Twad- dell.	Baumé.	Specific Gravity.
91	45.1	1455	121	54.4	1605	151	62.1	1755
92	45.4	1460	122	54.7	1610	152	62.3	1760
93	45.8	1465	123	55.0	1615	153	62.5	1765
94	46.1	1470	124	55.2	1620	154	62.8	1770
95	46.4	1475	125	55.5	1625	155	63.0	1775
96	46.8	1480	126	55.8	1630	156	63.2	1780
97	47.1	1485	127	56.0	1635	157	63.5	1785
98	47.4	1490	128	56.3	1640	158	63.7	1790
99	47.8	1495	129	56.6	1645	159	64.0	1795
100	48.1	1500	130	56.9	1650	160	64.2	1800
101	48.4	1505	131	57.1	1655	161	64.4	1805
102	48.7	1510	132	57.4	1660	162	64.6	1810
103	49.0	1515	133	57.7	1665	163	64.8	1815
104	49.4	1520	134	57.9	1670	164	65.0	1820
105	49.7	1525	135	58.2	1675	165	65.2	1825
106	50.0	1530	136	58.4	1680	166	65.5	1830
107	50.3	1535	137	58.7	1685	167	65.7	1835
108	50.6	1540	138	58.9	1690	168	65.9	1840
109	50.9	1545	139	59.2	1695	169	66.1	1845
110	51.2	1550	140	59.5	1700	170	66.3	1850
111	51.5	1555	141	59.7	1705	171	66.5	1855
112	51.8	1560	142	60.0	1710	172	66.7	1860
113	52.1	1565	143	60.2	1715	173	67.0	1865
114	52.4	1570	144	60.4	1720			
115	52.7	1575	145	60.6	1725			
116	53.0	1580	146	60.9	1730			
117	53.3	1585	147	61.1	1735			
118	53.6	1590	148	61.4	1740			
119	53.9	1595	149	61.6	1745			
120	54.1	1600	150	61.8	1750			



Distillation of bituminous minerals—by E. K. Mitting . . . . .	210
"    "    "    J. Patison . . . . .	209
"    "    "    H. L. Pattinson . . . . .	211
"    "    "    John Perkins . . . . .	219
"    "    "    Robert Porter . . . . .	224
"    "    "    R. B. Tennent . . . . .	220
"    "    "    James Young . . . . .	220
"    "    "    William Young . . . . .	215
"    "    "    William Young, A. Scott, and W. W. Stevens . . . . .	220
"    "    "    Paul Wagenmann . . . . .	219
Distillation of bituminous minerals—	
celled retorts—by Edward Meldrum . . . . .	279
continuous, by superheated steam only—by James Young . . . . .	271
continuous self-acting retorts—by John Gibbon . . . . .	280
continuously, by hot gases—by James Young . . . . .	274
high and low heats—by William Young . . . . .	284
hot gases—by James Young . . . . .	273
introduction of air or gas—by Charles Humfrey . . . . .	272
revolving retort—by J. F. Briujes . . . . .	282-283
"    "    J. P. Raeburn . . . . .	275
"    "    James Young . . . . .	282-283-284
rich in sulphur—by C. McLaren Irvine and Robert Slater . . . . .	217
special apparatus—by B. P. Walker and J. A. B. Bennett . . . . .	211
special method—by A. Munro . . . . .	277
"    "    John Young . . . . .	278
special method of heating retorts—by William M. Young . . . . .	270
special retort arrangement—by W. M. Fraser and J. Snodgrass . . . . .	273
special retorts—by J. G. Beckton . . . . .	277
"    "    G. T. Beilby . . . . .	268-269
"    "    Thomas Bell . . . . .	273-274
"    "    T. N. Bennie . . . . .	280
"    "    P. Brash and William Young . . . . .	286
"    "    William Brown . . . . .	271
"    "    P. Couper and M. Rae . . . . .	272
"    "    Allan Craig . . . . .	275
"    "    Andrew Craig . . . . .	275
"    "    C. M. Kernot . . . . .	272
"    "    Charles McBeath . . . . .	277
"    "    N. M. Henderson . . . . .	281
"    "    James Nicholas . . . . .	276
"    "    George Parkin . . . . .	277
"    "    William Young and G. T. Beilby . . . . .	277
"    "    William Young and P. Brash . . . . .	284-285
special retorts or ovens—by Robert Griffiths . . . . .	272
superheated steam—by Joseph Townsend . . . . .	274
under partial vacuum—by J. Harris . . . . .	274
Distillation of oils—by J. W. Perkins . . . . .	259
"    "    William Young and G. T. Beilby . . . . .	259

	PAGE
Distillation of oils—	
aided by steam and air—by E. A. Ripplingille . . . . .	289
contact substances and steam—by James Church . . . . .	293
continuously—by N. M. Henderson . . . . .	312-319
"    "    W. C. Holmes and J. W. Perkins . . . . .	286
"    "    A. G. Southby . . . . .	275
"    "    William Young and G. T. Beilby . . . . .	323
cracking—by James Dewar and B. Redwood . . . . .	324
"    "    A. C. Kirk . . . . .	293
"    "    Edward Meldrum . . . . .	291
"    "    Robert Scott and William McIvor . . . . .	292
high-pressure steam—by Joseph Townsend and P. Forbes . . . . .	292
off alkalies—by James A. McIntosh . . . . .	293
"    "    James Young . . . . .	290
special apparatus—by J. A. Coffey . . . . .	295
special fractionation—by H. W. C. Tweddle . . . . .	302
special, slow—by P. M. Cram and George Moir . . . . .	294
special steam superheating—by N. M. Henderson . . . . .	325
special still—by H. J. Haddon . . . . .	306
under pressure—by George Shand . . . . .	293
"    "    James Young, jun. . . . .	281-285
Discharging retorts—by George Anderson and James Buchanan . . . . .	298
"    "    J. Bell and Thomas Bell . . . . .	298
"    "    H. Shanks . . . . .	299
Fullers' earth, Pat. No. 2356, July 27, 1868. . . . .	290
Paraffin, extraction of—by J. Cox and S. Cox . . . . .	299
Purification of crude oil—by P. G. Barry . . . . .	271
"    "    R. A. Brooman and P. G. Barry . . . . .	271
Purification of oils—by C. Humfrey . . . . .	305
Purification of oils—	
gaseous muriatic acid—by James Young . . . . .	295-296
hot acid treatment—by William Smith . . . . .	292
muriatic acid—by James Young . . . . .	296
oxidation—by S. H. Emmens . . . . .	295
Purification of oils and waxes—acid, alkali and fullers' earth—by F. Lambe, A. C. Sterry and J. Fordred . . . . .	290
Purification of paraffin wax—by James Leach . . . . .	285
"    "    "    W. B. Nation . . . . .	281
"    "    "    James Soames and J. K. Soames . . . . .	282
refining. <i>See</i> Purification.	
retorts. <i>See</i> Distillation of bituminous minerals.	
Treatment. <i>See</i> Purification.	

PATENTEES.

Aitken, H. Distillation of bituminous minerals . . . . .	319
Anderson, George, and Buchanan, James. Discharging retorts . . . . .	298
Barrow, J. Distillation of bituminous minerals . . . . .	313



	PAGE
on, N. M. Distillation of oils—continuously . . . . .	312-319
"    "    —special steam superheating . . . . .	325
W. C., and Perkins, J. W. Distillation of oils—continuously . . . . .	286
, Charles. Distillation of bituminous minerals—introduction of of gas . . . . .	272
, Charles. Purification of oils . . . . .	305
ohn. Distillation of bituminous minerals . . . . .	308
u, A. N. Distillation of bituminous minerals . . . . .	322
D. McLaren, and Slater, Robert. Distillation of bituminous erals rich in sulphur . . . . .	315
, J. Distillation of bituminous minerals . . . . .	311
Distillation of bituminous minerals . . . . .	322
D. M. Distillation of bituminous minerals—special retort . . . . .	272
C. Distillation of oils—cracking . . . . .	293
F., and Sterry, A. C., and Fordred, J. Purification of oils and es—acid, alkali and fullers' earth . . . . .	290
ames. Purification of paraffin wax . . . . .	285
, Charles. Distillation of bituminous minerals—special retort . . . . .	287
, D. <i>See</i> Crane, P. M., and McGrath, D.	
, James A. Distillation of oils off alkalies . . . . .	293
William. <i>See</i> Scott, Robert, and McIvor, William.	
, Edward. Distillation of bituminous minerals . . . . .	301
"    "    "    "    —celled retorts . . . . .	279
"    "    "    "    Distillation of oils—cracking . . . . .	291
E. K. Distillation of bituminous minerals . . . . .	310
orge. <i>See</i> Crane, P. M., and Moir, George.	
. Distillation of bituminous minerals—special methods . . . . .	297
V. B. Purification of paraffin wax . . . . .	281
James. Distillation of bituminous minerals—special retort . . . . .	285
George. Distillation of bituminous minerals—special retort . . . . .	276
J. Distillation of bituminous minerals . . . . .	300
, H. L. Distillation of bituminous minerals . . . . .	315
John. Distillation of bituminous minerals . . . . .	270
J. W. Distillation of oils . . . . .	289
<i>See also</i> Holmes, W. C., and Perkins, J. W.	
obert. Distillation of bituminous minerals . . . . .	298
P. <i>See</i> Buhrer, J., and Price, A. P.	
<i>See</i> Couper, P., and Rae, M.	
J. P. Distillation of bituminous minerals—revolving retort . . . . .	276
<i>See</i> Dewar, James, and Redwood, B.	
le, E. A. Distillation of oils—aided by steam and air . . . . .	289
<i>See</i> Young, William, and Scott, A., and Stevens, W. W.	
bert, and McIvor, William. Distillation of oils—cracking . . . . .	292



Shand, George. Distillation of oils under pressure . . . . .	26
Shanks, H. Discharging retorts . . . . .	29
Slater, R. See Irvine, C. McLaren, and Slater, Robert.	
Smith, William. Purification of oils—hot acid treatment . . . . .	22
Snodgrass, J. See Fraser, W. M., and Snodgrass, J.	
Soames, James. Purification of paraffin wax . . . . .	28
Southby, A. G. Distillation of oils continuously . . . . .	27
Sterry, A. C. See Lambe, F., and Sterry, A. C., and Fordred, J.	
Stevens, W. W. See Young, William, and Scott, A., and Stevens, W. W.	
Tennent, R. B. Distillation of bituminous minerals . . . . .	33
Townsend, Joseph. Distillation of bituminous minerals—superheated steam . . . . .	21
Townsend, Joseph, and Forbes, P. Distillation of oils—high pressure steam . . . . .	22
Tweddle, H. W. C. Distillation of oils—special fractionation . . . . .	24
Wagenmann, Paul. Distillation of bituminous minerals . . . . .	29
Walker, B. P., and Bennett, J. A. B. Distillation of bituminous minerals—special apparatus . . . . .	31
Young, James. Absorbing or "coke" tower . . . . .	27
"    Distillation of bituminous minerals . . . . .	29
"    "    "    "    —by hot gases . . . . .	27
"    "    "    "    —continuous, by superheated steam only . . . . .	26
"    "    "    "    —continuously by hot gases . . . . .	27
"    "    "    "    —revolving retort . . . . .	282-283-284
"    Distillation of oils off alkalis . . . . .	29
"    Purification of oils—gaseous muriatic acid . . . . .	285-286
"    "    "    —muriatic acid . . . . .	28
Young, James, jun. Distillation of oils under pressure . . . . .	281-282
Young, John. Distillation of bituminous minerals—special method . . . . .	29
Young, William. Absorbing or "coke" tower . . . . .	30
"    Distillation of bituminous minerals . . . . .	28
"    "    "    "    —high and low heats . . . . .	28
"    "    "    "    —special method of heating retorts . . . . .	27
Young, William, and Beilby, G. T. Distillation of bituminous minerals—special retort . . . . .	317
"    "    Distillation of oils . . . . .	31
"    "    "    —continuously . . . . .	28
Young, William, and Brash, Peter. Distillation of bituminous minerals—special retort . . . . .	284-285
Young, William, and Scott, A., and Stevens, W. V. Distillation of bituminous minerals . . . . .	28

## PATENTS.

1850, October 17. No. 13,292.

YOUNG, JAMES. "*Improvements in the treatment of certain bituminous mineral substances, and in obtaining products therefrom.*"—These are, "the obtaining of paraffine oil, or an oil containing paraffine, and paraffine from bituminous coals," by treating them as follows: The coals broken into small pieces are put into a common gas retort, with a refrigerator kept at about 55° F.; the retort is then "gradually heated up to a low red heat, at which it is to be kept until volatile products cease to come off; care must be taken to keep the temperature of the retort from rising above that of a low red heat, so as to prevent as much as possible the desired products of the process being converted into permanent gas." The coke is then withdrawn, and the retort allowed to cool "below a visible red (to prevent the waste of the fresh material to be introduced), may be again charged." If desired, some of the matters are run from the retort by a pipe "provided in the anterior and lower part of the retort." Other arrangements for distilling may be used, "but in order to obtain the largest quantity of crude paraffine oil from coals by means of this process, and produce the smallest quantity of permanent gas by the action of the heat employed, whatever may be the apparatus used, care must be taken to heat the coals gradually, and to apply the lowest temperature necessary to complete the operation." The crude oil is heated to separate water and impurities, and distilled; the distillate is treated with sulphuric acid and afterwards with soda, and again distilled. This oil is distilled with water to separate a volatile fluid fit for illumination, the residue separated from the water is treated with sulphuric acid and afterwards with chalk; this oil may be burnt in argand lamps, or, alone or mixed with other oils, is used for lubricating purposes. The paraffin may be separated from this oil by cooling, filtering it out, and treating it alternately with sulphuric acid and soda.

1853, February 4. No. 307.

PERKINS, JOHN. "*Improvements in the treatment of certain bituminous mineral substances, and obtaining products therefrom.*"—These are, "the obtaining of paraffine oil, or an oil containing paraffine, and paraffine from bituminous mineral substances found in the coal formation, and known in their respective localities under the name of basses, black basses, bats, blaes, greasy blaes, shining blaes, coal shales, argillo bitumens, or bituminous argils, bituminous sandstones, and asphalt coals (not including bituminous coal), yielding bituminous matters by the application of heat." The apparatus is of the ordinary character; "a low red heat will be found to be the best temperature for getting the largest quantity of paraffine oil and the least quantity of permanent gas, and naphthaline products." The paraffine is obtained from the oil by crystallisation, filtration, treatment by sulphuric acid and washing with water.

1853, August 23. No. 1957.

BROWN, WILLIAM. (Provisional protection only.) "*An improved mode of obtaining volatile products from bituminous coals and other bituminous substances.*"—This consists in burning these substances "in a furnace so constructed that the upper portion of the charge" "is gradually acted on by the heat evolved from the lower portion of the charge, so that the volatile matters" of "the upper portion of the charge are driven off before such portion has descended sufficiently low in the furnace to undergo combustion."

1853, December 20. No. 2958.

WAGENMANN, PAUL. "*Improvements in the manufacture of liquid hydrocarbons and paraffin.*"—These consist in breaking "the coals or bituminous slate in pieces of about the size of a walnut, and if they are very sulphurous," "sprinkling them with lime water," and drying them in a drying furnace, in preference, particularly constructed. The coals or bitumens are distilled in retorts differing from gas retorts by having the pipes "letting out the produce of distillation" on "the opposite ends to those where the fire-doors are." The retorts are so arranged in a furnace that the flame from one fire is led to the others, so as "to heat the retorts by a graduated heat." The tar obtained is mixed with a solution of sulphate of iron and heat applied to "28° or 30° centigrade." The tar is now distilled by heat and steam under pressure into the

retorts. The distillate is fractionally collected into three products, Nos. 1, 2 and 3, according to their gravities, and they are further treated, according to their gravity, with certain percentages of sulphuric acid and soda and distillation. The paraffin is separated from the heavier oil by crystallisation, and purified by pressure treatment with sulphuric acid, &c.

1854, March 3. No. 515.

BROWN, WILLIAM. (Complete Specification, but no Letters Patent.) "*An improved mode of obtaining volatile products from bituminous coals and other bituminous substances.*"—This consists as follows: Instead of retorts or such like vessels heated outside, "substituting therefor an air-tight furnace into which the bituminous coals," &c., "are introduced, and the volatile products thereof are disengaged and obtained therefrom" by means of fire inside the furnace. The furnace is furnished below with furnace bars and a furnace door; at the top of the furnace is a hopper, through which the bituminous coals, &c., are "introduced into the furnace, and at the top of the furnace is also placed a still head for receiving the volatile products when disengaged."

1855, September 18. No. 2107.

BARRY, PIERRE GÉDÉON. (Provisional protection only.) "*Improvements in treating bituminous shale, boghead mineral, and other like schistous bodies, in order to obtain various commercial products therefrom.*"—These are, employing retorts and condensers in the usual way. The crude oil is rectified into oils by sulphuric acid, alkalies and distillation. The residue forms with caustic soda a black grease named "mineral paraphinized grease." The paraffin is separated from the heavier oils by filtration through bags, "and submitted to pressure."

1856, February 28. No. 516.

BROOMAN, RICHARD ARCHIBALD. (A communication from Pierre Gédéon Barry.) "*Improvements in treating bituminous shale, boghead mineral, and other like schistous bodies, in order to obtain various commercial products therefrom.*"—These are, in reference to this subject, by distilling and treatment with sulphuric acid and soda, of the raw oil, and fractionally redistilling the result, obtaining first, "essential oil," which may be used as a solvent for caoutchouc, &c.; second, "an oil for lighting purposes"; third, "a fatty unctuous oil for

lubricating machinery"; fourth, "a liquid tar for lubricating purposes"; fifth, "a solid tar"; sixth, "paraphine, white and transparent as sperm"; &c.

1858, May 19. No. 1117.

KERNOT, CHARLES MIDDLETON. (Provisional protection only.) "*Improvements in distilling shale, boghead, and other mineral matters.*"—These are, having in the upper part of the retort "two perforated plates, between which, when first distilling shale," &c., are "placed powdered coke and sand in layers, through which the evolved products pass, and are filtered on their way to the head and thence to the condenser." In re-distilling oils from mineral matters the tube to carry away the vapours descends some distance into the still, but is above the charge, and has at its upper end a gutter or hollow channel to retain the condensed products. In this pipe are "two perforated plates, between which are placed (in layers) matters suitable for acting on the passing products in chemical or mechanical manner." The matters are "black oxide of manganese, sulphate of iron, chloride of potash, bichromate of potash and others, according to the action desired to be produced."

1860, November 23. No. 2875.

HUMFREY, CHARLES, and HUMFREY, CHARLES, the younger. (Provisional protection only.) "*Improvements in distilling coal and peat and bituminous and coaly minerals, and in the treatment of the products therefrom.*"—These are, constructing and arranging "the retorts in which the decomposition of the mineral is effected in such fashion that the bottom on which the mineral is placed is heated strongly, while the top and sides are kept comparatively cold," and introducing into the same a stream of gas or air, so as to "carry off the vapours into the condensers as soon as formed, instead of leaving them for a long time in the retort." Steam may sometimes replace the gas or air.

1861, February 25. No. 486.

YOUNG, JAMES. "*Improvements in apparatus for the treatment or distillation of bituminous substances.*"—A series of vessels "or chambers being placed side by side, or in a circle, or in any other convenient position, are first filled with the bituminous coal, or other substance to be treated. A jet of steam of the temperature necessary for

effecting the distillation is then admitted into the first vessel of the series, and passing through the contents of the vessel raises the temperature thereof to its own heat, or nearly so, and is then by an outlet pipe carried to the second vessel, through the contents of which it passes, as before, being again carried to the third vessel, and so on throughout the series; the oils as they are condensed and the condensed steam being withdrawn from the vessels. After the oil has been distilled off the contents of the first vessel, the steam is cut off from that vessel and applied directly to the second vessel; the contents of the first vessel are then withdrawn therefrom, and that vessel is again filled with bituminous coals, or other substances to be distilled, and made the last of the series, and so on, so that the process is a continuous one. The permanent gas necessarily arising in the process will pass away from the vessel, which for the time being is the last of the series."

1862, March 3. No. 574.

BELL, THOMAS. (Provisional protection only.) "*Improvements in apparatus for distilling shale and other bituminous minerals.*"—These are, "to facilitate the treatment of large quantities of mineral rapidly and economically." There are "two or more furnaces, one of which communicates with a central vertical flue, having formed round it an annular chamber, whilst the other furnaces communicate with flues outside, encircling such retort chamber. A pipe or pipes are provided to carry away the volatile matters, and valved hoppers are arranged at the top of the retort chamber for the introduction of the minerals." The refuse or waste matters pass off by discharge tubes. The retort chambers are heated by internal and external flues, heated by separated furnaces or otherwise. The retort chamber may be divided, "or there may be two or more separate retort chambers disposed concentrically or otherwise, with intermediate flues."

1863, August 21. No. 2080.

GRIFFITHS, ROBERT. "*Improvements in the construction of retorts or ovens for extracting oil from certain descriptions of cannel coal or other bituminous substances.*"—These are as follows: A retort about one foot deep, four wide, and thirty long, "is built or fixed at such an angle that when small coals are placed upon the upper end of the retort they will slide down the sloping bottom thereof by their own gravity"; doors are fixed by screws, or otherwise, at each end, and

a pipe at the upper end, and another pipe not far from the fire end conducts "away the vapours formed by distillation to the condensers." "A furnace is constructed under the lower part of the retort, which at this part is horizontal, and a slide or dividing plate is introduced between it and the inclined part of the retort, so that the contents of the horizontal part may be discharged, and then by withdrawing the slide and allowing the coal to slide down the incline be readily refilled. The flue of the furnace passes under the entire length and width of the retort, passing out to a chimney at the top end thereof, or the flue may return over the top of the retort, and be conducted to a chimney placed in any convenient situation. In place of making the inclined portion of the retort straight, as before described, it may be of zig-zag form, or arranged at different angles in the course of its length. Each section or incline thus arranged has a slide to arrest the descent of the coals contained therein, so that the contents of each section may be allowed to descend in succession from one section to another." "When fully acted upon, openings or doors are formed at each angle for the introduction of a poker or rake when required; pipes are also applied for conducting the vapours away to the condensers as generated." Another arrangement of retort consists of a "horizontal cylinder having an internal openwork cylinder or portion of a cylindrical cage of iron or perforated earthenware supported therein, leaving an annular space between it and the interior of the retort, in which space the material to be treated is placed. At one end of this retort two doors are placed, one above the other, for supplying and discharging the contents, a pipe or pipes being applied at the other end to conduct the vapours to the condensers in the ordinary manner. A furnace is constructed underneath at one end of the retort with flues to conduct the heat around the retort, or the cylindrical retort may be placed in a vertical position with an internal cylinder forming a central flue, and with cylindrical cages forming annular spaces in which the cannel coal to be treated is placed. The flues from a furnace or furnaces are conducted through and around the interior and exterior of this arrangement of retort so as to heat the surfaces exposed thereto."

1863, September 14. No. 2255.

BELL, THOMAS. (Provisional protection only.) "*Improvement in apparatus for distilling shale or other bituminous minerals.*"—These are "a series of what may be termed horizontal edge retorts and

arranged side by side, but with intermediate spaces, in a building which is constructed with a series of furnaces disposed beneath the front ends of the retorts. The fire gases from each furnace pass up (by preference through a brickwork grating) into a space between two adjacent retorts, and along the bottom of that space beneath a horizontal partition towards the back end, whence they return above the partition towards the front end, finally entering a horizontal flue which crosses the tops of the front ends of the retorts, and conveys the gases from between the several retorts to the chimney. Each retort is formed with a mouth and a hopper in its top for feeding in fresh mineral, and with a door on its front end whereby to remove the exhausted materials, whilst the products of distillation pass off by a pipe at the back end, this pipe communicating with a space inside the retort, separated by a perforated vertical partition through which the products find their way."

1863, November 12. No. 2812.

CRAIG, ANDREW. (Provisional protection only.) "*Improvements in distilling hydrocarbons from coal, shale, and other bituminous substances, and in apparatus employed for that purpose.*"—These are, modes of distilling so as to get the hydrocarbons off as rapidly as possible. One is an annular retort, "the outer surface or wall of such retort being heated to the requisite degree" in any way, "whilst the whole or greater part of the inner wall is provided with a number of small openings through which the volatilized hydrocarbons pass into the central enclosed space" with all the arrangements for condensing them. Another mode is, the fire is in the centre, and small holes are "in the outer wall of the retort instead of the inner wall"; or, a narrow flat chamber is heated on one side to the requisite degree, "whilst the other side is provided with a number of small apertures." In each case requisite condensers are provided.

1863, November 19. No. 2899.

SOUTHBY, ANTHONY GAPPER. (Provisional protection only.) "*Improvements of stills or retorts for the distillation of petroleum or tars from coal or shale or the products thereof.*"—These are, "arranging a series of stills or retorts at different levels, so that tar poured into the uppermost one will descend to the lowest, so that what remains may be drawn from it or them either intermittently on cooling the still, or continuously in a liquid state through a refrigerator."



vessel, and so on through the series ; the oils as they are condensed being withdrawn by special pipes from the several vessels. So soon as the whole or the greater portion of the oils have been distilled from the charge in the first vessel, the hot gases are cut off from that vessel and passed directly through the second vessel, the contents of the first vessel being withdrawn, and so on throughout the series of vessels, each vessel being refilled as fast as it is emptied, the process being consequently continuous." "The permanent gases pass off from that vessel which is the last of the series for the time being by a pipe or pipes provided for that purpose."

1864, June 2. No. 1368.

CORMACK, WILLIAM. (Provisional protection only.) "*Improvements in the distillation or destructive distillation of all solid matters or semi-solid matters capable of yielding fluids, or gaseous hydrocarbons, or other products of any kind whatsoever, be they liquids, fluids, or solids, such as pit coal, boghead, or other bituminous coal or shale, peat, wood, asphalts, tallow, lard, fats, or other semi-solid matters, and in the treatment of the same.*"—These are, "introducing a jet, stream, or current of any atmospheric air, steam, or vapour, gas or gases, singly or combined, superheated or otherwise, into the retorts, ovens, or other vessels, such as are usually employed for their distillation." These vapours or gases are conducted "either above or near the surface," and by these means the products of the distillation are obtained at a considerably lower temperature than hitherto accomplished. Also using "the gaseous products given off from one or more retorts or vessels to be conducted into other retorts or vessels, or through a succession of them, and to act upon the surface of the matter to be distilled in the similar way as above described."

1864, October 10. No. 2484. (\* \*)

BECKTON, JAMES GEORGE. "*Improvements in heating retorts and other ovens for the distillation of shale, coal, and other substances.*"—Retorts employed in distilling lias and other shale, or coal, in order to manufacture petroleum, or other oils or gases, are connected with blast or similar furnaces, in order to be heated by their waste gases. Above a flue conveying the gases from the blast furnace, are arranged a series of oblong ovens, each one containing a number of retorts. These latter are suspended from their upper ends, leaving their lower ends unconfined, in two or more rows, parallel with the

flue, "so as to leave space between the rows to act as a chamber for the combustion" of the gases. According to one plan, the gases are introduced from the flue, and burnt in the oven without coming into direct contact with the substances being distilled. In the upper part of the flue, beneath the opposite ends of the oven, are two or more passages, terminating above as many grates, upon which fuel is burnt for the purpose of igniting the gases. The products of combustion are then conveyed through flues to the several ovens. "The upper ends of the retorts are provided with removable covers for charging in the materials, and are connected together by lines of rail" so as to be filled from waggons. "The products of distillation pass from the retorts" by means of internal perforated pipes, "and thence into a main." The remaining matters can be discharged from their lower ends into waggons running on rails beneath. In a modification of this process, the treated gases produced in the oven are reconducted directly into the retorts, "and come into absolute contact with the matters for distillation," instead of acting externally, and having their heat conveyed through the material of the retort.

1865, March 1. No. 571.

YOUNG, JAMES. (Provisional protection only.) "*Improvements in distilling bituminous substances and in apparatus employed therein.*"—These are, employing "for the distillation of such substances of a chamber or vessel with one opening at the top, by which the coal or other bituminous substance is introduced, and an opening at the bottom by which the residue is withdrawn; the heat required to distil the bituminous substance brings the hot products from the combustion of coke or other fuel forced or drawn through the interior of the chamber or vessel among the substances to be distilled."

1865, October 4. No. 2544.

CRAIG, ALLAN. (Provisional protection only.) "*Improvements in apparatus for extracting oil from coal, shale, and other minerals.*"—These are, drawing off the oil from the bottom of the retort, "which although attempted has been hitherto found impracticable, owing to the difficulty of keeping the dust and dirt out of the oil, and also the difficulty of discharging the coke from the retort." A retort, vertical, larger in diameter at the bottom than at the top, has "a hopper at the top for supplying the coal or mineral, and a vessel

containing water at the bottom, and with the usual fire-place and flues for heating the same." In the interior of this is "a casing constructed (by preference), in a cylindrical form, and consisting of a series of pieces or rings placed one above the other, so as to present a perfectly smooth and cylindrical surface on the exterior." A space is left between each ring, the lower edge of each ring overlapping the upper edge of the one below it. The oil escapes through these "spaces into the interior of the casing, and passes out through a horizontal or other pipe connected to the latter at or near its lower end." Although the internal casing is by preference cylindrical, it may be of any form desired, and also the "casing might be cast in one piece (instead of several), if the edges of the interstices are not made to overlap each other," but the first mode of construction is preferred.

1865, October 30. No. 2793. (\* \*)

MELDRUM, EDWARD. "*Improvements in the distillation of coal and shale, and in the apparatus employed therein,*" consisting in the adaptation thereto of "a cellular arrangement of retorts."—The longitudinal space between two brick walls is divided by transverse metal partitions, with fire-clay or metallic tops, so as to form a series of cells. The partitions are built up of tongued and grooved bars, jointed with fire-clay, bolted together, and having flanges at each end to keep the walls in position. The tops of the retorts have feeding hoppers and closing plugs for charging and discharging the fuel; and each cell has a metal lid at the bottom, with "a partly moving grating" for carrying the coal or shale. "Beneath this grating a pipe leads to a depositing vessel, from the upper part of which a branch pipe leads to an ordinary hydraulic main." In working the retorts each alternate cell is charged with the fuel, and the intermediate cells with the coal or shale to be distilled. The fuel is lighted from the top, each cell holding it being left open at top and bottom, and the distilling cells being closed. When the fuel is burnt down in any cell, it is replaced by coal to be distilled, while the coke left in the previously distilling retorts is lighted, in order to serve as fuel to distil the contents of the other retorts. If found requisite, the residuum may have fresh added to it. Instead of this alternate method of firing, the whole set may be charged with fresh material at each time; and the cells may be placed horizontally as well as vertically.

1865, December 2. No. 3101.

BENNIE, THOMAS NEWTON. (Provisional protection only.) "*Improvements in apparatus for distilling oils and condensing oily vapours.*"—These are, first, "the apparatus or retorts for distilling oil from shale and other substances." It consists of a pan provided with a cover through a gland in which the "shaft of an agitator passes. The agitator is caused to rotate by any suitable gearing," and is composed of claws or forks which turn over the shale while heat is applied beneath the pan. "The pan is provided with doors for charging and discharging and with an outlet in the cover for carrying off the vapours to a condenser." Second, constructing condensers for condensing the vapours of these oils. A tank of iron or other material is placed at a convenient distance from the back end of the retort. At one side of this tank a box is fitted "into which the pipe or pipes from one or more retorts is or are received," preferring "that these pipes should be tapered, the small end being towards the retort." The tank communicates by an opening with the box, so that the oily vapours are free to pass into the tank and into vertical or inclined tubes fitted to a plate on the top of the tank, the lower ends of these tubes are open to the tank, their upper ends communicate with a chamber which receives "any permanent incondensable gas" which may be conveyed to a gas holder for use. The chamber receiving the permanent gases is heated by a steam pipe "to melt any paraffine adhering to the sides of the tubes or to cause an upward draught if required."

1865, December 20. No. 3285.

GIBBON, JOHN. (Provisional protection only.) "*An improved retort for distilling or extracting products from cannel coal, shale, or schist and more especially from small coal or dust technically known as 'slack.'*"—This consists "in applying self-acting feed and discharge apparatus to a revolving cylindrical wrought or cast-iron retort," the inner surface of which has a projecting ridge which encircles it "in a spiral manner, the same as the interior of a female screw," and "is so arranged for the purpose of causing the material to be operated on to advance from one end of the retort to the other, which it will do of itself, as the retort revolves by following the course of the spiral screw or worm formed by the projecting ridge." In preference the ends of retort are "taper or narrow" to "connect them to the feed and discharge ends respectively, which ends are of less diameter than the body of the retort, and are also provided

with spiral ridges on their inner surfaces in the same manner as the interior of the retort. The feed and discharge ends revolve in stuffing boxes, the feed end being connected with a hopper, into which the material to be operated upon is fed," and the discharged end is connected with a chute, and "the gas or vapour passes through the said discharge end into a condenser of any suitable and convenient form." The retort may be inclined, mounted on brickwork, heated with one or two fires, "and by means of worm or other suitable gearing, the retort may be caused to revolve."

1865, December 27. No. 3345.

YOUNG, JAMES, Junior.—"*Improvements in treating hydrocarbon oils.*"—These are, "treating certain hydrocarbon oils, such as paraffine, so that their specific gravity is thereby reduced, and their properties otherwise altered," "by heating and distilling these oils under pressure." The distilling vessel should be capable of resisting "a pressure of at least one hundred pounds to the square inch, the heat being applied thereto in the usual manner." In practice "a pressure of about twenty pounds to the square inch in the boiler or vapour generating vessel is suitable for the treatment of heavy hydrocarbon oils obtained from coal or shale, but such pressure may be varied to some extent." It will be found in all cases that the result of the process "is to convert the hydrocarbon oils in whatever state they are operated upon, whether they be light oil, heavy oil, or both mixed together, into oils of a lighter nature."

1866, February 1. No. 322.

NATION, WILLIAM BRYER. "*Improvements in the purification and hardening of paraffin wax.*"—These are, "the purification and hardening of paraffin wax by separating the more liquid and softer portions from the harder portions contained therein by repeatedly subjecting the melted paraffin to the process of agitation and cooling until it commences to solidify, and then separating the portion which remains fluid from that which has already solidified," by drawing it off by a tap from below. Also the use of cold water as follows:—15 cwt. of crude or scale paraffin is melted in a vessel of 1 ton capacity by means of steam, when melted, the steam is turned off, and agitators are caused to revolve slowly, while at the same time a stream of cold water is run in the agitator and the flow of cold water is continued "until the mixed contents of the vessel register on Fahrenheit's thermometer a mean temperature of from 2 to 6

degrees, more or less, below the point at which the material under treatment melted, previously to undergoing this operation of agitation and cooling," but no lower. The agitation is then discontinued, on standing, the discoloured liquid portion separates and is drawn from the bottom by a tap, and the process is repeated as above as often as required. "The harder and purified portions of the scale paraffin separated by either of the above systems if not sufficiently white for the market, can be remelted and further bleached by any of the methods usually practised, and finally filtered in a hot filter, as is well understood."

1866, February 14. No. 471.

SOAMES, JAMES, and SOAMES, JAMES KOLLE. "*Improvements in purifying paraffin.*"—These are, mixing "the paraffin with an oil capable of saponification," and subjecting "it when so prepared to heavy pressure, which in a great part expels the oil, and with it the impurities' of the paraffin." The process is repeated "until the impurities are sufficiently removed," and the paraffin is then treated to "remove the small quantity of oil which the press is unable to squeeze out." In place of using an oil as above, "a saponifiable grease containing a considerable quantity of oil may be used. Thus lard may be employed; but it is not found advantageous to use a grease in place of an oil, as the stearine it contains is inoperative, and has to be removed by saponification."

1866, February 15. No. 478.

YOUNG, JAMES. "*Improvements in distilling coal, shales, and other substances.*"—These are, employing "a revolving retort combined with feeding and discharging apparatus arranged so as to produce a continuous process" as follows:—The retort is placed at an angle, and made to revolve on its longitudinal axis by any well-known mechanical contrivance for imparting a continuous rotatory motion in one direction, such revolution in conjunction with the inclined position of the retort causing the materials placed therein to pass through the retort, which being heated externally by a furnace situate beneath it will effect the distillation. "The retort of iron or other suitable material has a hopper at the upper end for charging, and a discharge pipe or pipes at the lower end for discharging the materials after distillation." The volatile products pass off by an exit pipe or pipes at "the upper end of the retort or distillatory apparatus."

1866, March 1. No. 625.

YOUNG, JAMES. "*Improvements in distilling coal, shales, and other substances, and in apparatus employed therein.*"—These are, employing "a retort placed either horizontally or at an angle, so constructed that it may be made to revolve, and containing a screw or spiral, the revolution causing the materials placed at the end of the retort," by means of a hopper, to be guided or conveyed through it by means of a screw or spiral, "whilst the retort being heated effects the distillation of the materials. The retort or distillatory apparatus may be constructed of iron or other suitable material supplied with suitable exit pipes, through which the volatile products of distillation pass off, in order that such volatile products may be collected and utilized."

1866, March 13. No. 756.

BRINJES, JOHN FREDERICK. "*Improvements in machinery or apparatus for distilling bituminous shale and other bituminous substances of a like nature.*"—These are, the general construction and arrangement of one and more horizontal retorts for the above purpose as follows:—For distilling "shale, boghead coal, and other light bituminous substances which are not liable to cake, whilst under the action of heat," employing one or more horizontal retorts of cast iron or fire clay, revolving continuously in one direction or receiving "a reciprocating or alternating motion round their longitudinal axes by means of a 'mangle wheel' and pinion or other well-known mechanical contrivance for converting a continuous rotatory motion into a circular reciprocating movement." These retorts revolving continuously in one direction have in the interior spiral ribs. "When the retorts receive a circular reciprocating motion on their axes they are provided in the interior with double inclined projections and a series of annular flanges" which divide the retort into a number of annular chambers, each communicating with its neighbour by an opening left for that purpose in each ring or flange. The retorts are set over a furnace so as to have the flame all round. In some cases the bituminous matters are fed continuously at one end by a hopper, and the residuum is discharged "into a receiver or it may be discharged into a second or third retort similar to the first, and be finally discharged from the last retort of the series," one or more of the retorts are provided with a pipe at one or both ends connected with condensing apparatus.

1866, April 6. No. 992.

YOUNG, JAMES. "*Improvements in distilling.*"—These are, "using a revolving retort or still containing a spiral made of iron or other suitable material, which I place either in a horizontal or inclined position and cause to revolve. The substance to be distilled may be a solid or a liquid, the whole or part of which is volatile being introduced into the retort or still at the one end and being guided by the spiral is conveyed towards the other end, where the portion not volatilized is discharged, the volatile portion being driven off while passing through the heated retort." The feed pipe leading from a cistern containing the liquid to be distilled passes through a stuffing box at the point beyond a stop-cock where it passes into the retort, the discharge end of the retort is similarly entered into a stuffing box in the discharge piece for receiving or passing away parts of the substances which have not been distilled through a pipe out of this end of the retort. Reference is made to No. 625, A.D. 1866.

1866, May 4. No. 1278.

YOUNG, WILLIAM, and BRASH, PETER. "*Improvements in the distillation of coal, shale, and other bituminous substances to obtain oil matters therefrom, and in the redistillation of products thereby obtained.*"—These are, first, the uncondensed or permanent vapours or gases when distilling coal, shale, &c., are returned back into the retorts containing the coal, shale, &c., which is being distilled; these gases, it is said, "disappear in part, whilst at the same time the yield of easily condensable oil is increased." The vapours or gases should be heated before they are returned into the retorts to avoid any chilling action. These vapours, it is said, are also advantageous in carrying forward with them "the vapours rising from the water-oil which is being distilled. It is preferred to pass the vapours which are difficult of condensation back under false bottoms in the retorts." A jet of steam or a forcing or exhausting apparatus may be used to pass the vapours through the retorts. In redistilling what are known as "still bottoms" residues from distilling bituminous oils, there are obtained vapours or gases not easily condensed. These vapours are passed back into the still, or the vapours coming from the still may, in a separate vessel, be mixed with the vapours which are difficult of condensation, and heated with them; "oil easy of condensation results from the action of the two different vapours the one on the other."



1866, June 12. No. 1600.

NICHOLAS, JAMES. (Provisional protection only.) "*Improvements in retorts, and in the mode of working the same to obtain crude paraffine and other oils from cannel coal, bituminous matter, wood, peat, bones, or other material.*"—These are, constructing a retort so "that a large superficial area of almost any size can be submitted to the direct action of heat, and is of the following construction:—The bottom of the retort is a plane surface, by preference an iron plate; the sides, back, front, and top consist also of similar plates connected together by means of flanges, thus forming a sort of box or retort. At the back, by preference on the upper portion of the retort are holes or pipes by which the products of distillation pass to ordinary condensers." On the top of the retort is a lid arranged on the principle of an hydraulic joint, for the purpose of charging the retort. In the retorts are rakes. The joints between the flanges are formed "with molten lead in lieu of water," and covered with "sand or other material to prevent rapid oxidation." Prior to the retort being drawn or discharged a small quantity of water is dispersed into the retort by a perforated pipe which rising into steam sweeps "what volatile matter remains in the charge out into the condensers."

1866, June 26. No. 1697.

YOUNG, JAMES, the younger. (Provisional protection only.) "*Improvements in apparatus for the treatment of hydrocarbon oils.*"—These are, treating "crude or more or less refined" paraffin petroleum oils in order to reduce "the specific gravity of such oils," and improve "their properties for illuminating purposes." A boiler or distilling vessel capable of resisting "a pressure of at least 100 lbs. to the square inch" is charged with the oil; heat is applied, the vapour produced "is allowed to pass to the condenser at any regulated pressure through a pipe provided with a valve loaded to the pressure required, or a separate tube with regulating stop-cock may be provided for allowing the vapour to pass to the condensing apparatus." The boiler or vessel has a pressure gauge, and it is constructed so as to be readily cleaned out.

1866, July 23. No. 1905.

LEACH, JAMES. (Provisional protection only.) "*Improvements in refining paraffine wax.*"—These are, boiling "the crude paraffine for about two hours, more or less, with a solution of caustic alkali,"

"the precipitated oil is then removed by washing; the paraffine is then submitted to the action of animal charcoal" filtered, pressed, then remelted, washed, and "again subjected to the purifying power of charcoal, after which it is again filtered and treated with about five per cent. of naphtha and pressed; by preference, the pressing should take place while warm. To remove more completely any impurity that may still exist it is once more remelted, washed, treated with charcoal and filtered, all that remains to be done is to run the paraffin into cakes suitable for the market."

1866, September 4. No. 2271.

HOLMES, WILLIAM CARTWRIGHT, and PERKINS, JNO. WM. (Provisional protection not allowed.) "*Improvements in apparatus for the distillation of paraffine and petroleum or other hydrocarbon oils.*"—These are, taking "the usual flated hemispherical still," fixing in the interior about midway a charging pipe with a self-acting cock, and carrying the neck of the still through an intermediate condenser, to which the charging pipe is also attached. "The condenser is provided also with a self-acting cock to receive and maintain the charge, so as to supply the still and maintain one uniform level while at work with boiling oil." At the bottom is a pipe for removing any water in the oil. "In the interior of the still, is a pyrometer, self acting, so that when the boiling point has risen to any point previously determined on, any further supply may be and is cut off. The condenser being charged with oil charges the still and maintains the charge at the same level, thus obviating any burning or discolouring of the oil, and requiring little or no attention."

1866, September 17. No. 2380.

BRASH, PETER, and YOUNG, WILLIAM. "*Improvements in the manufacture of oil from shale and other bituminous substances.*"—"These are, the distillation of shale or other bituminous matter in combination with the tar," as afterwards described, "in order to obtain oil in greater quantity than the shale or other bituminous matter would produce separately." The acid tar precipitated by adding sulphuric acid to crude bituminous oils, having "little or no commercial value is prepared by neutralizing the acid with lime or other base, or the acid is washed out by blowing steam into it;" "the separation may be rendered more complete by the addition of

salt." The purified tar is absorbed by ashes or other absorbent material, and charged "into the retort in a solid form, together with the shale or bituminous matter." Or the purified tar is mixed with lime or other alkaline matter, and distilled along with the shale or bituminous matter. Or the shale or bituminous matter is mixed with lime or other bituminous matter, and distilled "along with the tar which is allowed to flow over and through the shale and lime during the distillation." The distillation is conducted, by preference, in the manner described in No. 1278, A.D. 1866.

1866, October 29. No. 2788.

MCBEATH, CHARLES. "*Improvements in the treatment or distillation of shale, coal, and other bituminous substances, and in the means or apparatus employed therefor.*"—These are, "the construction and use of an open-mouthed oven or retort erected over a hearth or grate for the treatment or distillation" of the above substances "into gases by the heat of their own combustion at the open mouth of the retort" (whether these gases are condensed into oils in the condensers after described, or in others heretofore in use or whether used as gases); also, "the application and use of a jet or stream of steam at or near the neck of the conduit carrying the distilled gases from these improved retorts to their condensers, or applied to other retorts and condensers heretofore or at present used" for the treatment or distillation of the above substances, "whether used in connection with the returned currents of uncondensed gases from the condensers or not, and whether these currents of gases to and from the condensers are assisted or partially produced or not by a fan or other equivalent blast in addition to the said steam jet." The condenser is a long cylinder connected to the neck leading from the distilling oven, from which it declines at a considerable angle towards the ground, and rests on suitable pillars of brickwork. This condenser is fitted with six pairs of transverse diagonal surface condensing pipes or tubes open to the atmosphere, and through which currents of cold air ascend and escape at the top, or these currents may be conducted by one conduit connecting all the pipes at their upper ends to a chimney, or this heated air or a portion of it may be led into the ash pit. There is an arrangement by which the uncondensed olefiant gases are returned through the condensers. The retorts or ovens are fed with the above substances by means of a hopper on the top.

1866, November 3. No. 2847.

HARRIS, JOSIAH. "*Improvements in apparatus for the production distillation, and refining of hydrocarbon and other oils from shale, cannel coal, peat, lignite, or other bituminous minerals.*"—These are, placing "an ordinary exhausting fan or pump to be driven or worked by steam or other motive power at the required velocity at the delivery pipe leading from the retorts" or "at the ordinary outlet of the condensing worm leading from the still," and thus drawing off "the vapours, fumes, smoke, or gases generated in the retorts during distillation" of the above substances, and drawing off in a like manner from the above substances "such vapours, fumes, smoke, or gases as are generated in ovens or kilns for conversion into hydrocarbon oil."\*

1867, February 1. No. 284.

BUHRER, JACOB, of Munich, and PRICE, ASTLEY PASTON, of London. (Provisional protection only.) "*Improvements in the distillation of coal, shale, &c.*"—"The materials are to be reduced to a fine state of division, and then caused to pass or fall through the interior of a heated vertical chamber, tube, or a retort, or series of the same, in such a manner as that the several particles in their descent or passage shall be subjected to the action of heat, applied externally, to the retort &c. The character of the distillatory products being dependent on the temperature employed for their production, it follows the apparatus must be heated more strongly when it is desired to obtain illuminating gas than when the object is the production of oil and other condensable products."

1867, March 7. No. 650.

YOUNG, WILLIAM, of Straiton; and BRASH, PETER, of Leith. "*Improvements in the distillation of shale &c.*"—"The shale &c. are heated by the gases given off by itself. The shale is enclosed in a vessel provided with an outside casing which is to convey the gas; heat is applied to the outside casing and is diffused through that to the inner chamber containing the shale &c. the gas or vapour is then by a suitable pipe at the bottom introduced between the outer casing and the inner chamber, and after ascending it is forced or drawn into a downward current through the bituminous matter

\* All the above extracts of Patents were taken from *Abridgments of Specifications relating to Oils, Fats, Lubricants, Candles and Soap*, published by G. E. Eyre and William Spottiswoode, 1873.

carrying with it the oily vapours, thus effecting a downward distillation which produces an oil of high quality. Instead of the outer casing or chamber, which conveys the vapour or gas, a pipe or arrangement of pipes for the same purpose may be used. By means of the downward distillation a larger quantity of solid paraffin is obtained from the oil than by any other mode known."

1867, March 12. No. 707.

BRINJES, JOHN FREDERICK, Whitechapel, London. "*Improvements in apparatus for distilling shale, &c.*"—"The improvements are in the means of traversing the material or substance under treatment through the retort in which it is contained. One or a series of horizontal cylindrical retorts are made to revolve continuously in one direction to receive a circular reciprocating motion on the axial centre line of the retort. Each retort is provided internally with a series of longitudinal ledges or ribs, which serve as lifters, and allow the material to fall in a shower on to the bottom of the retort, and according to the angle of these ribs so will the passage be retarded or hastened, (of the shale)."

1867, June 21. No. 1808.

PERKINS, JOHN WILLIAM, of London. (Provisional protection only.) "*Improvements in stills for petroleum, paraffine oil, &c.*"—"The still consists of a series of chambers in communication with each other, each of which chambers contains a coil of pipes through which the heating medium is caused to flow. At the extremity of the heating medium I maintain the current through the still by means of an ordinary force pump enclosed in a tank of oil for supplying the charger with hot oil, and the discharge pipe of the still is encased in an ordinary 'Liebig's' condenser."

1867, June 27. No. 2175.

RIPPINGILLE, EDWD. ALEXANDER, Holborn, London. "*Improvements in the mode of distilling or separating the more volatile portions of petroleum, &c.*"—"The improvements consist, firstly, in the employment of a jet or jets of steam to draw or force in a current or currents of air through the petroleum or other mineral the volatile matter of which is to be separated; such jets acting in a somewhat similar manner to the blast of a locomotive engine. The oil to be treated is placed in a vessel in which a finely perforated

pipe or pipes in a coil, is arranged at the lower part; with this pipe is connected a pipe passing from the aforesaid vessel to another vessel, into which a jet or jets of steam are blown, such jets of steam acting to draw or force in air to such vessel from which a combined current of air and steam passes from the upper part thereof to the perforated pipe in the interior of the oil treating vessel. The combined current of air and steam, issuing through the perforated pipe passes in numerous small jets up through the oil and out through a 'gooseneck,' connected with the upper part of the oil vessel, and in doing so carries with it the more volatile portions of such oil, which are then conveyed into another vessel and condensed in any suitable way."

1868, June 6. No. 1868.

YOUNG, JAMES, of Kelly, Renfrewshire. (Provisional protection only.) *'Improvements in treating hydrocarbons.'*—"This invention consists essentially in heating and distilling hydrocarbons, such as paraffin, paraffin oil, and petroleum in contact with or from alkalis or alkaline earths."

1868, July 27. No. 2356.

LAMBE, FREDK., and STERRY, ARTHUR CHAS., of Rotherhithe, London, and FORDRED, JOHN, of Blackheath, Kent. *"Improvements in the treatment of solid and liquid hydrocarbons."*—"This invention consists in treating these substances with fuller's earth under certain conditions. For wax or semisolid hydrocarbons the material is first melted, and the earth thoroughly stirred into it. After the earth has been sufficiently agitated with the material, the whole is left for the earth to subside, or it may be filtered. When treating liquid oils we first place them in a still with a proper quantity of fuller's earth, and distil them in contact with it generally, but not necessarily to dryness, with or without the assistance of steam as may be found necessary. Liquid hydrocarbons are subjected to a preliminary treatment with sulphuric acid, or alkali and acid before distillation. The products of this distillation may be treated with the earth, or simply washed, or treated only with acid; the liquid being finished with ammonia or its carbonate. Sometimes it is preferable to use as a final treatment a small percentage of silicate of soda or potash to prevent the oil going back in colour. The thin tars produced may be used for washing the crude oils previous to distillation."

1869, February 6. No. 376.

MELDRUM, EDWARD, Dechmont, Linlithgow. "*Improvements in the manufacture of paraffine oil.*"—"An apparatus such as an iron tube or a common retort is built up over or alongside of a fire so that the temperature can be so regulated as to attain a range of temperature not exceeding a visible red heat, and to obtain a large surface to be heated, such apparatus may be filled with broken stones or spent shale. The heavy oils or the melted paraffine are to be run in slowly at one end of a retort or decomposing tube, and the products thus resulting are condensed by passing off through a condenser connected with the other end of the retort. A mixture of paraffine and oils when distilled at about 700° F. will split up into easily refined oils for lamps, and heavier oils suitable for lubricating, &c."

1869, February 26. No. 600.

TOWNSEND, JOSEPH, of Glasgow, Lanark. "*Improvements in extracting and refining oils from minerals, &c.*"—"Superheated steam is passed into the upper end of the retort, and is maintained at at least  $\frac{1}{2}$  lb. per sq. inch over the atmospheric pressure. The retort is preferably circular, 12 feet by 12 feet of iron (fire-clay lined) plates. It is to have a perforated bottom through which the steam and what it extracts pass to an inclined bottom leading to an exit tube at the side, this pipe or tube first descends a little, then ascends to any convenient height, whilst at the top or any convenient height, a loaded valve is applied to it, to prevent the passage of liquids or gases except at a predetermined pressure, to which the valve is loaded, and maintained in the retort as well. The condensed products are to be passed through heating baths in coils, and the products in each coil collected separately. Heated air or any heated gas may be used in place of steam. The steam, air, or gas may be admitted at the top, and the exit pipe placed at a different part, but the arrangement described is preferable. If the oils are to be extracted from tar or other more or less liquid substances, the retort is constructed with horizontal platforms with ledges and extending alternately from opposite sides to within short distances of the other sides. The tar or other matter is placed on the top platform, and overflows in succession down upon each lower one, whilst the heated steam, air, or gas passes off with what it extracts to the exit pipe."

1869, May 13. No. 1469.

TOWNSEND, JOSEPH, and FORBES, PETER, both of Glasgow. "*Improvements in the refining or treating of oils.*"—"A jacketed retort is used and steam (saturated) at 50 lbs. per sq. in. may be at first employed, and the pressure to be gradually increased to 150-180 lbs., the increase being adjusted so as to ensure a regular flow of the distillate. In this way the light oils are distilled over comparatively pure, whilst the residue after treatment with acid and alkalies, and crystallizing, may be separated into lubricating oils and wax by ordinary pressing."

1869, June 15. No. 1832.

SMITH, WILLIAM, of Bathgate, Linlithgow. (Provisional protection only.) "*Improvements in treating or purifying mineral oils.*"—"The invention consists principally in employing sulphuric acid diluted with from one half to twice its weight of water, the acid and water being mixed with the oil whilst in the heated state caused by their combination, the oil also being preferably heated to 100° F. prior to adding the acid and water. The treatment may be performed twice, or oftener if necessary. The tar produced is thinner and better fitted for making grease, &c."

1869, September 1. No. 2588.

SCOTT, ROBERT, Manager of Addiewell Works; MACIVOR, WILLIAM, also of Addiewell. (Provisional protection only.) "*Improvements in the treatment of hydrocarbon oils.*"—"This invention has for its object the reducing of the specific gravities and otherwise improving hydrocarbon oils. The oil is put into any ordinary still and distilled, and the vapour given off is passed through one or more heating vessels or chambers sufficiently heated to produce the change. The change may also be brought about by bringing the vapours into contact with superheated steam. Heavy petroleum and paraffine oils may by this means be converted into burning oils. After being superheated the vapour is conducted to a condenser of the usual or other form. This treatment may also be applied to the vapours of crude oil from coal or shale undergoing distillation."



1869, October 11. No. 2950.

KIRK, ALEXANDER CARNEGIE, of Glasgow, Lanark. (Provisional protection only.) "*Improvements in treating mineral oils.*"—"This invention is for the reduction of the specific gravity of the heavier portions of paraffin, and other mineral oils, and consists in distilling them in a still of any known convenient construction, and in causing the vapour, as it leaves the still to issue at a high velocity through a contracted orifice or orifices by forming a partial vacuum in the condenser or in the pipe leading from the still. This may be effected either by pumps, or by what is known as an ejector condenser."

1870, January 6. No. 50.

SHAND, GEORGE, of Stirling, N.B. (Provisional protection only.) "*Improvements in obtaining products from tars and residues.*"—"The process consists in distilling under pressure. The heat may be applied by means of superheated steam, or saturated steam of high pressure, or direct fire heat, in any of the known apparatus in use, for distilling under pressure. Five to 10 pounds per sq. in. above the atmospheric pressure is to be preferred. 'Coal-tar oil' may by this mode be made to yield naphtha, light oils, and lubricating oils, not hitherto obtained from it; whilst if tar or partially treated tar is used, larger quantities of naphtha and light oils may be obtained than heretofore."

1870, July 1. No. 1871.

MCINTOSH, JAMES ANDERSON, of Leith, Midlothian. (Provisional protection only.) "*Improvements in distilling oils.*"—"Milk of lime is thoroughly incorporated with the oil, and then passed into the still, after which soda crystals are added to the mass which is again agitated till the crystals dissolve. The still is then put in order and fired, and the slower and more gentle the distillation is effected the better will be the oil in smell, purity and brightness of colour. The proportions for 1st distilled paraffin blue oil are: 30 cwts. of blue oil, 60 gallons of milk of lime, and about 2 cwts. of soda crystals. This treatment may be applied to any oils whether they have been distilled once or twice before."

1871, February 4. No. 305.

CHURCH, JAMES, of Glasgow. "*Improvements in distilling and in apparatus therefor.*"—The retorts can be made circular or of a polygonal horizontal section, and each of a series is formed with an

enlargement at the part where the heated gas is to act on the substance in the retort, the enlargement being fitted with a horizontal diaphragm having a central opening through which the substances descend. The heated gas is admitted into an annular space at one side of the diaphragm, and acting on the substances, and passing through the diaphragm passes off from the other side of it, carrying the volatile products with it. Either modification of the retort may be constructed of brickwork or iron, or partly of both materials. When dealing with a liquid (crude shale oil, &c.) the retort is filled with coke or other indifferent body, and the liquid is poured in slowly at the top so that as it drips down over the coke it is presented in thin films to the current of heated gas. When dealing with a solid substance, such as shale, the latter is preferably reduced to small pieces, and fed in at the top, and the retorts may if necessary be fitted with covers, the shale being charged at intervals, but the process is practically continuous. A pressure slightly above the atmospheric is preferred, in order to prevent the air entering, and to control the currents of gas in the various channels by means of jets of steam or otherwise, so as to have the pressure a little higher at the sides of the retorts at which the gas enters than in the passages leading from the retorts to the condensers."

1871, November 6. No. 2989.

CRANE, PATRICK MOIR, and McGRATH, DENNIS, both of Manchester. "*Improvements in liquid coolers, and collecting the congealed product.*"—"A stationary horizontal cylinder is fitted with a jacket containing a stream of cold brine, or cold air. The cylinder contains an archimedean screw, which accurately fills it so far as to bear upon the whole interior circumference, and the screw is to be rotated. The liquid flows into the cylinder and congeals in a thin film, and is scraped off by the screw, and finally squeezed out at the end into the usual bag or receptacle provided."

1871, November 13. No. 3055.

CRANE, PATRICK MOIR, and MOIR, GEORGE, of Manchester. "*Improvements in the manufacture of lubricating materials.*"—"The oil is distilled by a slow or cool distillation, and after the lighter or thinner portions have come over, we reserve the heavier portions which come over by a higher temperature for use as lubricating materials, and which if mixed with paraffine wax are to be separated

from it by a well-known means. These heavier oils are to be purified with acids and alkalies in the usual way, they are then washed with water and thereby rendered fit for use."

1871, November 18. No. 3130.

EMMENS, STEPHEN HENRY, of Gresham Street, London. "*Improvements in purifying distillates from bituminous substances.*"—"A current of the distillate in the form of spray is distributed in atmospheric air, in pure oxygen, ozonized oxygen, or other oxidizing gas, for the purpose of producing a direct oxidation of the substances which it may be desirable to remove. The purifying process may be carried on by blowing or injecting a jet of spray into a closed vessel or chamber from which the product or products can be removed by filtration, decantation, or otherwise, aided or not by the addition of acid, or alkalies, according as the oxidized matters to be removed are basic or acid."

1871, August 11. No. 2123.

YOUNG, JAMES, of Limefield, Midlothian. "*Improvements in the treatment of hydrocarbon oils.*"—"Shale or other hydrocarbon oils produced by distillation, either in the crude state or partially purified, are placed in a suitable vessel, and muriatic acid gas passed into them to saturation point, (the oil being warm at starting). After settling the oil is drawn off from the acid liquor. The oil in this state is washed with water, after which it will be found that nearly all the impurities are removed, and if required the oils may be distilled or otherwise treated. The acid can be passed into the oils by a pipe or in any other convenient manner. I claim this to be quite distinct from Mr. Warren de la Rue's Patent 2002 of 1855 for treating 'Burmese naphtha' with commercial acid."

1872, January 8. No. 64.

COFFEY, JOHN AMBROSE, Bucklersbury, London. "*Improvements in the manufacture of oil by distillation.*"—"I place the oil, &c. into a retort or still, which I enclose in an outside jacket in some cases, and in others I use it or dispense with it and introduce a heated mass into tubes, or ducts, or any other well-known form which will encase the heating material and which will prevent it, unless through convection, to impart its caloric to the material operated upon. The heated mobile substance I obtain from a dense paraffin

oil or any other such substance as will impart its heat and maintain its mobility. I take a vessel, which I term my supply, return, and expansion cistern, in which I place the heavy paraffin oil, and circulate it by an outlet and inlet (both open, thereby avoiding all pressure from heat,) through pipes or ducts to a zig-zag, worm, or other shaped pipes or ducts, boiler shape or other form, which I place in a furnace, stove, fusible or sand bath, which I convey to a pyrometer indicating 1500° Fahr., so that I can accurately know the temperature of the fluid, and thereby also regulate the temperature of the mobile substance to the retort or still to the material to be operated upon. The circulation may be maintained by a pump or the well-known principle of the hot water apparatus by which means I ensure the steady and controllable heat to the substances under operation."

1872, February 8. No. 413.

YOUNG, JAMES, of Kelly, Renfrewshire.—"*Improvements in the treatment of natural petroleums.*"—"The improvements consist in treating what are called 'natural petroleums' with muriatic acid. Either liquid muriatic acid is used, and the oils may be heated above the atmospheric temperature or not. When liquid muriatic acid is used the petroleums may also be heated. The 'petroleums' are agitated with the said acid in stoneware or other suitable vessels to remove the impurities. The agitation can be effected by means of ordinary reciprocators or dashers in use. The oils can be distilled afterwards if thought necessary." See also No. 2123 of 1871.

1872, February 14. No. 459.

YOUNG, JAMES, of Kelly, Renfrewshire. (Provisional protection only.) "*Improvements in treating hydrocarbons.*"—"I treat hydrocarbons which are solid or semisolid at ordinary temperatures such as ozokerite, pitch, or natural bitumens, with muriatic acid in the gaseous state. These substances are to be liquefied by heat and in that state are to be agitated with the said acid in a gaseous state, to remove the impurities. The agitation is to be effected by ordinary or reciprocating agitators or dashers, and the vessels are of stone or other material capable of resisting the action of the acid."

1872, February 28. No. 617.

YOUNG, JAMES, of Kelly, Renfrewshire. "*Improvements in treating hydrocarbons.*"—"The paraffin oils obtained by distillation are heated,

and liquid muriatic acid brought into contact with them, during agitation, in stone or other acid resisting material. Muriatic acid both liquid and gaseous may be used."

1872, February 28. No. 618.

YOUNG, JAMES, of Kelly, Renfrewshire. "*Improvements in obtaining hydrocarbons from shale &c.*"—"Atmospheric gases and products of the material from which the heat has been derived are mixed with the hydrocarbons sought to be obtained, and the kilns, furnaces, &c. are combined with a tower or chamber containing coke or other material between the spaces of which the vapours, gases and oils pass. Between the before named kilns, &c. and the tower, a condenser is situated in which the more readily condensable portions condense, the less so pass through the tower, wherein they become mixed with hydrocarbon oil which is caused to flow through the tower to absorb the less condensable portions."

1872, March 30. No. 938.

MUNRO, ANDREW, of Kensington, London. (Provisional protection only.) "*Improvements in the extraction of oil and from bituminous substances.*"—"Heated gases are to be passed over the body of the coal, shale &c., contained in a proper vessel. The gases preferable for this purpose are the heated products of combustion, which may be prepared by driving, drawing, or conducting air over a fire of any suitable combustible matter. The fire is to be so arranged that all the oxygen supplied is combined with carbon. A bed or layer of red hot coke, besides the fire may sometimes be necessary, and the position and arrangement of this fire must be such as to effect the control and regulation of the temperature of the heated products passing away from such fire, when making oil, that the temperature of the shale, &c. being operated upon, shall not be higher than that which is favourable for the largest production of oil and the products thereof. I prefer to drive a blast of air from an air pump over a coke fire, arranged on the lines above stated. The heated products of combustion are led into the chamber containing the shale, &c.; and I prefer to introduce these heated products at the top or upper part of the chamber. The distillation will thus proceed downwards. The bottom of the said chamber I prefer to keep open ended, sealing it in a bath of water. The products of the distillation along with the heated products of combustion pass off by suitable outlets to the condenser."

1872, April 11. No. 1073.

BELL, JOHN, junior, and BELL, THOMAS, both of Wishaw, Lanark. (Provisional protection only.) "*Improvements in apparatus for discharging horizontal retorts.*"—"To carry out this invention a small locomotive steam engine is arranged to run on rails in front of a bench of retorts or between two benches facing each other. The driving wheels are actuated through gearing which can be disengaged, and a pinion can be engaged so as to act on a transverse horizontal rack bar carried by the engine. A rake bar is provided that can be fixed upon either end of the rack bar, to suit the retorts on either side, and this rake bar is supplied with plates to close or partly close, when it is pushed in the retorts, and to open and grasp the materials in the retort when it is drawn out, depositing the materials in trucks between the rails and retorts."

1872, May 16. No. 1494.

PORTER, ROBERT, of Chiswick, and PORTER, FREDERICK, of Mincing Lane, London. "*Improvements in distilling and in apparatus therefor.*"—"The improvements consist in passing the charge of material to be distilled in a thin stream through a vertical retort, so that the whole of the said charge is kept in contact with the sides of the retort, and the entire heated surface thereof is utilized, while the central portion of the retort is left free for the passage of the vapours or gases evolved. The retort is fixed vertically upon a receptacle for the exhausted material, and to the upper end is fixed a hopper or reservoir to contain the distillable matter. In the hopper and through the retort we place a central shaft, the upper end projecting through the top of the hopper. On this shaft we fix a screw or worm for feeding the charge from the hopper into the retort. The threads or blades are to be inclined at an angle of 45 degrees downwards."

1872, June 12. No. 1768.

ANDERSON, GEORGE, and BUCHANAN, JAMES, both of Dalmeny Oil Works, Linlithgow. (*Void*, as the patentees neglected to file complete specification.) "*Improvements in apparatus for drawing the charge from retorts.*"—"The apparatus consists of a continuous or jointed metal rod or bar, or of a chain, fitted with a plate or series of plates. It is placed in the retort before or during charging, and is allowed to remain there during the distillation of the coal, cannel,

shale, &c. The rod or bar is preferably withdrawn by a steam windlass running on rails. A series of plates separated from one another is to be preferred, the one at the back end (the one furthest in the retort) to be the largest."

1872, June 12. No. 1771.

SHANKS, HUGH, of South Queensferry, Linlithgow. (Provisional protection only.) "*Improvements in drawing retorts and means therefor.*"—"The improvement consists in a rod or shaft, (to be worked by manual power or machinery) on which are fixed at distances from each other a number of 'clats' or rakes. Each rake is to be gradually larger, the smallest is to be nearest the mouth of the retort, the largest being at the back. The rakes may be perforated to allow the vapours and gas from the distillable material, to pass through it. After the distillation is finished the door of the retort is removed, and the shaft and rakes drawn out with the residue."

1872, July 24. No. 2204.

COX, JOHN, East Stockwith, Lincolnshire, and COX, SAMUEL, of Camberwell, London. (Provisional protection only.) "*Improvements in the extraction of paraffin &c. by distilling a volatile solvent through it.*"—"The materials with a suitable solvent are placed in a plain or perforated cylinder with a perforated bottom contained in a double cased cylinder with a double bottom closed by a cap having deep dipping rims dropping into the space between the inner and outer cylinder containing water to form an air tight joint. This cap is perforated in the centre, and around such perforation are placed two collars the one of larger diameter than the other to form a space for water and to admit a pipe fitted also at the end with a collar. The vaporous solvent coming in contact with these joints cannot pass through them, because it is immediately condensed or driven off according as to whether the water is hot or cold. The volatile solvent is distilled from another cylinder of exactly the same construction by means of steam passed into the water within the space between the double cylinder through the just described pipe which is connected with the head of a condensing worm fitted also with a water joint. The vapour is here condensed and passes through a pipe connected at the bottom of the worm by a sliding and revolving water joint into another double cased cylinder as above described. In this cylinder the condensed volatile solvent saturates the paraffin

containing substances, and with the oil or fat in solution falls to the bottom of the cylinder, and is recovered by distillation into a third or the first cylinder containing more materials to be acted on. By using three or more cylinders, as the solvent during distillation is being prepared for another cylinder, thereby rendering the operation continuous, and the solvent can be used over and over again without loss."

1872, August 21. No. 2487.

YOUNG, WILLIAM, Magdalen Chemical Works, SCOTT, ANDREW, Musselburgh Gas Works, and STEVENS, WILLIAM W. (for late Peter Brash, of Leith), all of Midlothian. "*Improvements in the destructive distillation of coal, shale, &c.*"—"The vapours generated are caused to pass in a downward direction through the hot coke from a previous charge. The retort is to be first heated (by coal, &c. thrown into the combustion chamber) to a very dull red heat. The substance to be distilled is then introduced by the hopper and valve at the top, and as soon as oil begins to come over, the exhaust (preferably a jet of steam) is set to work. The outlet for oil vapours is to be situated at the side of the retort; the whole to be enclosed in suitable flues, and the spent products of combustion carried off to the chimney. Any ordinary condenser may be used. As soon as one charge becomes exhausted, it is drawn off into the combustion chamber, and it supplies heat, for the next charge of material, which should be immediately introduced at the top."

1873, February 15. No. 569.

PATISON, JOHN, of Airdrie, Lanark. "*Improvements in the destructive distillation of coal and shale.*"—"For the distillation I use cast iron cylinders from 18 inches to 3 feet in diameter, and from 18 to 30 feet in length, more or less, whether in one casting or more, bolted or united together in any way. The said retorts are fitted with a shaft or shafts revolving inside and running parallel with said retorts, and placed in or on the said shafts or shaft, radial screw blades, either cast with or bolted on to the shafts, so as to form one continuous screw. A little space is to be allowed between the screw blades and the sides and tops of the retorts for the free escape of the gases, vapours, and other products of the distillation into the condensers. The oils can be purified by redistillation or by the usual treatment with acids and alkalies."



1873, April 10. No. 1327.

HENDERSON, NORMAN MACFARLANE, Oakbank, Mid Calder. "*Improvements in destructive distillation of shale and other oil-yielding minerals, and in apparatus therefor.*"—"In carrying out this invention a series of four vertical retorts are arranged in a furnace or oven, with their bottom ends at a little distance above a central firespace or grate. Their bottom ends are provided with doors which can be shut gastight, and immediately below each door is an inclined valve, which in one position separates the bottom of the retort from the central firespace, whilst it can be turned over outwards to allow the spent shale to fall into the firespace. The four retorts are preferably charged and drawn at separately equidistant periods. More or less of the permanent gas formed during the distillation may be led into the firespace to aid the combustion. Any number of retorts may be arranged in one oven, either horizontal or inclined."

1873, July 12. No. 2407.

MELDRUM, EDWARD, of Dechmont, Linlithgow. "*Improvements in the manufacture of and production of paraffine oil.*"—"The coal or shale is to be distilled from a cupola or furnace similar to a blast furnace, so constructed and arranged that the non condensable or permanent gases from such distillation may be introduced above the place where air is admitted, so that any free oxygen may combine with such gas before coming in contact with the products of distillation, and thus prevent their oxidation and destruction. A brick furnace (instead of iron as hitherto) is used, similar to an iron smelter's cupola, or on a larger scale, similar to an iron worker's blast furnace, admitting air at the bottom of the furnace to cause combustion of carbon in the spent shale, and admit gas obtained from the shale at several places round the retort, from one to several feet above the air inlet, to ensure complete combustion and combination of the atmospheric oxygen and prevent destruction and oxidation of the products of distillation, the said furnace being closed, and having exit pipes to carry off oil, vapour, and gases to a condenser. Superheated steam may be introduced into the upper portion of the distillatory apparatus, in order to carry forward the oil vapour to the condenser. The shale in the furnace is distilled by the heat carried up by the products of combustion, regulated in such a manner by admission of air and gas to cause low destructive distillation, and thus formation of paraffine oil, in a space inside the

furnace immediately above the place of combustion, and regulated in such manner by admission of such gas that no oxygen can possibly pass upward to the place of distillation uncombined with carbon or hydrogen, the said gas being an incondensable product of distillation from the shale."

1874, May 23. No. 1824.

BELL, JOHN, of Wishaw, Lanark. "*Improvements in distilling coal and shale.*"—"A tubular retort fixed in a horizontal position or at a suitable angle is to be employed. The retort contains a shaft so constructed that it may be made to revolve in bearings at each end of the retort, the said shaft carry portions of a screw thread and also flat blades, each portion of the screw thread consisting of one complete turn of the screw, the flat blades and screw thread to alternate along the shaft. The edge of the screw and the blades are to be made so as to nearly touch the inner surface of the retort but yet revolve easily. The portions of the screw are to move the charge onward from one end to the other of the retort, and the blades are to turn it over repeatedly on its way. The screw blades are perforated to allow the gases generated to pass along the retort to the eduction pipe. The shaft is to be revolved by a revolving tangent screw or other power. The distillable material is to be either roughly ground or reduced to a fine grain, as may be found necessary; and the retort ought never to contain much more than half the quantity that could be forced into it. The gases are condensed in the usual way."

1874, July 29. No. 2642.

TWEDDLE, HERBERT WILKIN COLQUHOUN, of New York and London. "*Improvements in the manufacture of paraffine and lubricating oils.*"—"A still is to be used heated directly or indirectly by fire heat. In this still are dry steam pipes, and a steam pipe perforated for the admission of common steam, superheated, or decomposed steam as may be desired. The dry steam pipes may be dispensed with. The said still is connected by suitable pipes to a pump. To produce a vacuum in the still, and draw off the products of distillation, there is a condenser between the pump and the still. Crude petroleum of 33° to 50° B. at 60° F. are taken, and the distillate taken off as follows: first distillate from 62° to 63° B. residue put in vacuum still, and take off 38 to 45 per cent. illuminating oil

collected in one receiver ; then 20 to 30 per cent. more distillate is collected in another. The residual oils are dark green in colour, have little odour, and contain no separated carbon and are useful for lubricating purposes. The third distillate is to be chilled, and the paraffin separated by pressure. The oil after this can be purified by simple exposure to sunlight, or can be refined by redistillation and a slight chemical treatment. The retort is to be made of wrought or cast iron, and has an upright cylinder with a perforated diaphragm, or two or more, in the interior through which the vapour from the still must pass to come in contact with the water injected or drawn in by the vacuum maintained therein. The water and oil separate on condensation in a pipe which must be at least 32 to 40 feet below the exit from the condenser where the oil is drawn off in a water seal or trap. The oil is drawn off by its appropriate pipe to the pump which maintains the vacuum, and pumps the oil into a suitable receiver. The oil, after expressing the paraffine, will be found to have great viscosity in relation to its specific gravity 30° to 34° B., and it has hardly any odour, colour or fluorescence by reflected light."

1875, September 7. No. 3137.

YOUNG, WILLIAM, of Clippens, Renfrewshire. "*Improvements in obtaining hydrocarbon vapours from gases, and in the apparatus employed therefor.*"—"A vertical tower or chamber constructed of metallic iron or other material is employed. This is to be divided into two compartments by an arch of brick or other non-conducting substance. The upper compartment is filled with coke in the same manner as ordinary coke towers at present in use, while the lower compartment is arranged in the same way as a 'Coffey' still. (*Vide* No. 1393 of 1865.) Into the bottom of this compartment or a still a pipe conveying live or exhaust steam is introduced. From the top of the still or compartment there is connected a pipe leading to any convenient condensing arrangement. The gases containing the diffused vapours are passed into the bottom of and up through the coke in the upper compartment, at the same time the oil for effecting the absorption is drawn from a tank and pumped into the coke compartment, and over the surface of the coke, which oil, as it gradually descends absorbs the hydrocarbon vapours, and the gases as they ascend become denuded, and are then drawn off by a pipe placed at the top of the coke compartment. The heavy oil containing the absorbed volatile hydrocarbon is drawn off at the

bottom of the coke compartment and conveyed by a pipe to a coil, placed in a vessel, through which the denuded hot oil from the still is passed. The gases and heavy oils may be brought into contact under pressure. The gases and oils are pumped into the coke compartment, the denuded gases being allowed to escape into the outlet pipe by a weighted safety valve (or their expansive force may be used to assist in pumping a fresh portion of saturated oil into the coke compartment), the saturated oils being drawn off at the base by a regulated ball cock. An ordinary still may be used, but the 'Coffey' is preferred for a continuous process, and the heat of a fire may be used in place of steam."

1875, November 12. No. 3934.

BENNIE, GEORGE, of Glasgow, Lanark. "*Improvements in retorts and their fittings and appurtenances connected therewith for the distillation of shale, coal, and other bituminous substances.*"—"I erect a set of long vertical retorts, preferably four (or one to six), made slightly tapered or conical from the throat or neck of the charging filler at top to the larger discharging mouth at bottom, in pairs parallel transversely and as close as their hoppers or flanges will allow within a rectangular arched stove, furnace, or heating chambers, in brickwork, and carried by the upper flange and lower snugs or collars on each upon the upper and lower set of three strong transverse iron bars, or equivalent plates built into the brickwork forming the heating chamber, with the lower mouth some considerable distance above a duplex movable fire grate or set of hinged furnace bars, below each pair of retorts, ranged parallelly to each other across the lower part of the heating chamber, and sufficiently above a transverse passage, to allow the trucks or boxes on wheel frames to receive the ashes and remove them, and which run on rails or guide plates laid at the bottom of this passage. The retorts are charged full of the broken up shale into the annular space, between their inner surface and the open central gas conducting tube, from the bottom to the top of the latter, and are then heated through from the outside by the heat generated within the chamber, at first by coal, coke or other fuel charged on the hearth through the furnace mouth and closing doors, in the middle of the opposite sides of the brickwork, and afterwards either wholly or partially by the residuary hot ash and solid unconsumed carbon discharged at the outlet doors of the retorts after the gas and oil have all been distilled off."

1876, May 12th. No. 1998.

HUMFREY, CHARLES, Hough Green, Chester, Cheshire, England. "*Improved method of treating mineral oils.*"—"I first submit the oil (shale, coal, petroleum &c.) to a careful fractional distillation, and collect the heavy portion of the product. Instead of mechanical agitation of the oil with chemicals as has heretofore been the practice, I force a large stream of compressed air through a pipe at or near the bottom of the vessel, by which a thorough and complete agitation is caused, and a considerable oxydizing effect is produced, powerfully aiding the action of the chemicals used, at the same time the great volume of air passing through carries off all traces of low gravity and boiling points, the result being lubricating oil possessing more body and higher flash point than any mineral lubricating oils heretofore made, making it especially adapted for lubricating the pistons, slide valves, and other parts of marine and other engines."

1877, March 29. No. 1246.

YOUNG, WILLIAM, of Clippens, Renfrewshire. "*Improvements in the destructive distillation of coal, &c.*"—"The improvements consist of:—First. In producing or inducing the decomposition or destructive distillation of coal, shale, and other bituminous substances, used for the production of gas by causing a rapid agitation or circulation of the volatile products inside the retorts or other distilling or decomposing vessel, either by means of mechanical pistons or by the agency of jets of compressed gas, steam, or vapour, with the object of bringing about a more regular or equal decomposition into oil or permanent gas as may be desired of the elements of the coal or other substance, and in some cases increasing the volume of gases by the decomposition of steam or other vapours, employed to produce the current, and also by blending or combining, or carburetting the gases injected (to produce the currents) whilst in rapid agitation or circulation, in contact with the products of decomposition. The retorts or distilling vessels may be set either vertically or horizontally, provided that arrangements are made for a rapid agitation of the products of distillation through or over the substance being or to be distilled. Second. In improved means of producing a rapid separation of those hydrocarbons from the crude gases, which it is desirable to remove in the liquid form, and at the same time in retaining in the gases, those hydrocarbons, which are valuable as being of high illuminating power. This is accomplished by causing the gas to go through narrow passages kept heated, these passages

being preferably of a tortuous nature, causing the gas to flow alternately from side to side, or by causing the crude gases to impinge in narrow minute streams against heated surfaces; or alternately the gases may be highly heated, and passed through narrow passages, or impinged against surfaces, whilst in this heated state; or by distributing the gases and causing them to pass through small tubes or perforations in a series of trays containing the condensed tars or other matters, these latter being kept in a heated state. Third. In sealing or luting the cover or door of retorts or distilling vessels, more particularly shale retort doors, by having the door and retort mouth turned, planed or otherwise faced, or a groove either in the door or retort mouth, or in both, in which steam or compressed gas is passed at a pressure exceeding that inside the retort or distilling vessel. Fourth. In so arranging the method of conducting the distillation of shale, &c., for oil, that the charging and discharging doors may be closed by lids or covers similar to that employed in coal gas manufacture, and known as Morton's self sealing lids. This part of the improvement is effected by having the outlet for the products of distillation placed immediately at the doors or openings of the retorts, so that any air that may find its way into the retort does not require to pass through the substance being distilled, and at the same time the outlet is kept so low that any oil condensed on the lid runs into it, an exhaust being preferably kept on the retort during the time it is used."

1880, February 10. No. 574.

HADDON, H. J., of Westminster, for Elijah Weston, Buffalo, New York. "*Improvements in oil stills.*"—"The shell of the still may be set in brickwork, connected in the usual manner with the uptake. The shell is cylindrical in form, and provided with a series of fire tubes, distributed at about equal distances from each other, passing longitudinally through the same, and connecting the combustion chamber and uptake. A sliding grate is arranged within the combustion chamber, to operate to close the upper tiers of fire tubes when the quantity of oil within the still has been reduced by evaporation below the level thereof. The partition plates (which are generally made of thin sheet iron or steel) are bent to conform to the contour of the adjacent heating surface. These plates should be located at such distance from the heating surfaces as to permit a free circulation, and contain sufficient oil in the space separated to prevent burning, and to cover the heating surfaces. Different

kinds and densities of oil will require greater or less space to effect the above conditions, which may be readily determined in practice. The function of the partition plates is to separate that portion of the oil next the heating surface from the remaining and greater portion, which causes a variation in the temperature of the separated portions. The portion next the heating surface being of higher temperature, naturally rises, and its place is supplied from below by the outer part. This action causes a constant circulation, and causes every portion contained in the still to flow in a reduced quantity in direct contact with the heating surfaces, so that every particle of the oil is subjected to the highest degree of heat contained in the still, which produces a rapid and perfect volatilization. The receptacles for collecting the products are not described, being too well known to be needful."

1880, April 17. No. 1578.

YOUNG, WILLIAM, of Clippens, Renfrew. "*Improvements in the destructive distillation of shale for the obtainment of mineral oil, and in the apparatus or means employed therefor.*"—"The object of these improvements is to bring about economies in the use of the fuel employed in the destructive distillation of shales which do not contain sufficient carbon for their distillation. The air supplied to the shale, coke and coal is first heated by passing it through a series of regenerative passages connected with the ovens or retorts, which passages are so arranged that they are heated by the waste products of combustion of the fuel used to heat the retorts, and by the gas, coal, or other fuel used to supplement the heat from the carbon in the shale coke. Instead of using the coal commingled with the shale coke, I use it in a supplementary furnace, separate from the combustion chamber, but communicating with the oven or chamber in which the retorts are set; or I first convert the solid fuel into gas, and burn this gas in the combustion chamber, or in the supplementary chamber connected with the oven. To obtain a supply of steam economically I use the waste steam resulting from the manufacture of sulphate of ammonia from the liquors obtained in distilling the shale, or waste steam from other sources. To cause the waste steam to pass through the retorts, I either exhaust them so that the steam may be drawn through them, or blow it through them by means of a steam jet, the steam so drawn or forced, being heated to free it from moisture, and prevent its chilling the contents of the retorts. This steam in passing through the retorts acts in the

well known manner of washing out volatile products and forming ammonia with the nitrogen. The doors of the retorts and chambers are to be made in one piece to open or shut together."

1880, August 6. No. 3218.

IMRAY, JOHN, London ; for Reiner Rieth, Bonn, Germany. (Provisional protection only.) "*An improved method and apparatus for distilling hydrocarbons from coal, shale, and other carbonaceous matter.*"—"The coal or carbonaceous matter to be treated is placed in a retort and heated to a moderate heat. The retort has opening from it two pipes, an inlet and an outlet pipe, the outlet pipe leads to coolers, in which the products of distillation are partially condensed, the condensed matters being collected in suitable vessels with which the coolers communicate. The uncondensed portions of the products are drawn by a pump or fan, and caused to pass again through the retort in contact with the heated carbonaceous matter, from which they take up a fresh portion of condensable matter, and thus the products of distillation are caused to circulate through the retort and the coolers until the material in the retort is exhausted.

1881, April 12. No. 1875.

YOUNG, WILLIAM, Seafeld House, Lasswade, Midlothian. "*Improvements in the manufacture of mineral oil and ammonia.*"—"The oil is to be distilled off in one retort at a low temperature, and thereafter the residue is to be transferred to a second retort, heated to a considerably higher temperature ; or the operation may be performed in one long retort, so divided that the shale shall be distilled free of its oil at one end and the distillation for ammonia completed at the other end, steam being employed for liberating the ammonia at the hot end."

1881, May 18. No. 2169.

BEILBY, GEORGE THOMAS, of Mid Calder, Midlothian. "*Improvements in distilling shale, &c., and in apparatus therefor.*"—The retort employed in carrying out the invention is a tube, which may be inclined, but is preferably vertical, and the upper part of it is made of iron, and the lower part of fire clay. The upper end at which the shale is introduced is closed by a door or by the ordinary hopper and bell, and the lower end is closed by a door, or it may be continued by an iron tube dipping a few inches into water. The exit pipe for the oil vapour is connected to the upper iron part of



the retort. The retort is built singly or with others in an oven heated by a coal, coke, or gas-furnace, the fire gases being led by flues so as to first act on the lower fire clay parts and keep them at a bright red heat. The partly exhausted fire gases or portions of them are subsequently passed in contact with the upper iron parts of the retorts if found necessary. A current of steam is passed into the retorts, being introduced at the lower parts thereof. As the shale or other mineral gradually moves down each retort it is at the upper part subjected to a moderate temperature suitable for yielding oil in the best manner, the distillation being effected by the heat of the vapours or gases rising from the lower part of the retort, either alone or with some application of external heat. By the time the material descends to the fire clay portion of the retort it will have yielded up all or most of its oil, and then application of the greater heat will cause it to give a greater yield of ammonia than is obtained with retorts constructed, arranged, and worked in the usual way."

1881, October 3. No. 4284.

BEILBY, GEORGE THOMAS, of Mid Calder, Midlothian. "*Improvements in distilling shale, &c., and in apparatus therefor.*"—"The upper parts of the retorts are suspended by means of counterweighted levers, or otherwise suitably held up, so that their weight or a large part of it does not rest on the lower parts, which are subjected to the higher heat, and thereby rendered liable to injury by superincumbent weight. The retorts are also held in the brickwork in a manner to allow of their expansion or contraction by temperature changes without causing injurious strain; that is to say, the upper parts are not rigidly fixed but are left free to move to the necessary extent through the openings in the brickwork or supports. The retorts are preferably of circular section, and of small dimensions, being placed comparatively close together, and each group of four is provided with a single feeding hopper at the top, saving labour and expense, whilst a single pipe connected to the hopper piece serves for leading off the oil from all four retorts. The fire gases are led from the spaces in which they act on the retorts into one or more chambers or ovens, in which is placed apparatus, for generating and superheating the steam which is passed into the retorts, for assisting the separation of the oil, but more especially for assisting the separation of the ammonia after the oil, or nearly all the oil, has come off. The steam heating-apparatus consists principally of horizontal (or nearly so) tubes of malleable iron or steel arranged in one or

more vertical sets, those of each set being connected at alternate ends by elbow pieces to form one continuous serpentine course from top to bottom. The tubes are filled (or partly so) with pieces of iron borings, &c.; and the water is injected into the uppermost tube of each set in a small continuous stream, regulated according to the quantity of steam required. The steam thus made is superheated as it passes onwards, the borings, &c., giving a great surface, thus rendering apparatus of a small size very efficient."

1882, August 9, No. 3792.

MITTING, EBENEZER KINNARD, Rye, Sussex (Eng.). "*Improvements in the production of distillates from Kimmeridge shale.*"—  
"The retorts are of any of the usual shapes, either vertically or horizontally set in brickwork, heated by fire or gas. The shale is to be broken up in any convenient manner, and placed in the retorts. When the Kimmeridge shale is thus gradually heated in the closed retorts, the first products are, ammoniacal liquor, tar, and a small quantity of permanent gas. These products are carried off, by a pipe, inserted conveniently at the back of the retort, but not higher than the top of the retort. This pipe leads to the coil of a condenser of ordinary construction, but with a very large condensing surface, and a 'drag' or partial vacuum is created in it by an exhausting steam jet, or by the usual mechanical gas exhauster. As soon as the temperature of the retort has reached 210° to 250° C., I introduce steam into the retort at any convenient pressure; and so regulated in quantity as not to materially reduce the temperature of the retort; the steam may also be superheated. The pipe is made zigzag or spiral in shape, and is perforated at the end to allow of the exit of the steam. The steam is introduced at this stage and during the remainder of the operation, to assist it, and to absorb or decompose certain noxious bases, and carry them over in solution, which would else be taken up by the distilled oils, thus rendering them difficultly purifiable. When the temperature reaches dull red heat no more tar will come off, and the distillation is finished. The retort is allowed to cool below visible red heat, when the carbonaceous residue is quickly drawn from it into a sheet iron cylinder with tight fitting lid, to prevent absorption of gases and impurities from the air while cooling. The retorts may be so arranged that the operation is continuous, i.e. the shale may be fed in at one end and the residue taken out at the other."

1882, October 23. No. 5032.

JAMESON, JOHN, Akenside Hill, Newcastle upon Tyne. "*Improvements in dry distillation.*"—"The shale &c. is placed in a reverberatory furnace, and the gas or other vapors, exhausted downwards through the base of such furnace."

1883, January 20. No. 335.

WALKER, BERNARD PEARD, of Birmingham; and BENNETT, JAMES ALFRED BERESFORD, of King's Heath, Worcestershire. "*Improvements in apparatus used for the distillation of coal, shale, and other similar substances.*"—"This invention consists of a horizontal retort, the lower part of which is semi-circular in transverse section, but the upper part is not limited to any particular form. The retort is provided with a mouthpiece at each end, and at the top of the front end there is attached a hopper, from which the coal or shale is fed into the retort. This hopper may be furnished with a feeding screw in connection with a source of motion, and may or may not be partially or wholly surrounded with a water jacket. The back end of the retort also has a mouthpiece to the upper part of which is fixed the pipe for conveying away the gas or hydrocarbon vapour, and from the lower part of which depends a chute, terminating in a large receptacle for the reception of the coke or ash, capable of being opened and closed by a gastight door. Extending the whole length of the retort, and projecting through stuffing boxes in, and beyond the mouthpiece at each end, is a hollow cast or wrought iron shaft. The part of the shaft within the retort has formed around it a screw made up of segments or otherwise, and so placed that the lower part of the screw comes nearly into contact with the bottom of the retort. The front end of the shaft outside the mouthpiece has a spur wheel, pinion or worm, through the intervention of which the shaft may be made to revolve by any suitable motive power. The opposite end of the shaft has a pipe attached to it by which the heated air passing through the shaft may be conveyed to the furnace. By this means the furnace is supplied with heated air while the shaft is kept sufficiently cool to prevent it from bending. If found necessary provision may be made for the attachment of an iron plate extending the whole length of the upper part of the inside of the retort and is so arranged as to be removed and re-inserted or renewed from time to time. The action of the apparatus is as

follows: The retort being heated by the ordinary or other suitable form of furnace, the hopper being supplied with coal &c., and the jacket supplied with water, on motion being imparted to the screw, the coal will fall or be fed from the hopper into the mouthpiece, and from thence by the revolution of the screw in the retort it will be slowly propelled to the back end thereof, and in the course of its transit will yield up its gas or hydrocarbon vapours which will be conveyed away by the pipe at the back of the retort, while the coke will fall into the receptacle constructed for it, and be removed at convenient times."

1883, February 1. No. 540.

HENDERSON, NORMAN M'FARLANE, of Broxburn, Linlithgow. "*Improvements in refining or distilling mineral oils and in apparatus therefor.*"—"The invention may be applied in the treatment of various kinds of mineral oils and at various stages of the refining process. In one arrangement of the apparatus for treating shale or coal oil after it has undergone one distillation subsequent to its obtainment by destructive distillation from the shale or coal there are arranged in connection three horizontal cylindrical stills placed near together and heated by ordinary furnaces a convenient size for these stills being 7 feet in diameter by about 19 feet in length. Each still is fitted with an outlet or discharge pipe in the bottom at one end, and an inlet pipe enters the still at the same end of the still at a higher level, but is continued inside the still to the other end, so that the actual inlet may be as far as possible from the outlet in each case. Both inlet and outlet orifices open upwards, provided with safety plug valves for closing them. Each still is formed with the usual vapour dome or chest into which the volatilized oil rises and from which it passes into a long horizontal cylinder or pipe wherein its heat is utilized in raising the temperature of the oil being continually fed into the first of the three stills. The oil supplied to the first still is passed through the feed heaters of all three stills, and is fed in continuously; and whilst the distillation is proceeding in each of the three stills, there is a continuous transference of oil from the first to the second, and from the second to the third still, and from the third to one or more residue stills. The temperature maintained in the second still is higher than the first, and the third higher than the second; in consequence of which the oils vaporized in the several stills are of different specific gravities, but the oil vaporized in or distilled over from each still is always of an equality or gravity so long as the feed and the heats

applied to the several stills are properly regulated. In the first still the oil fed in enters at a suitable distance from the bottom whilst the oil which is transferred from the bottom of the first still enters the second still at a suitable distance from the bottom, the oil from the second to the third also enters it at a suitable height above the bottom. In the third still as there is a tendency for coke or adhesive carbonaceous matter to separate from the oil, there are fitted certain plates or dishes to promote the circulation of the oil, and to form receptacles for the coke so that it shall not adhere to the bottom of the still. Two or more residue stills are preferably provided with each set of three connected stills, so that while one of the residue stills is being cleaned out there may be no interruption in the continuous action of the three stills."

1883, February 28. No. 1087.

BARROW, JOHN, Clayton, near Manchester. "*Improved mode of and arrangement of apparatus for effecting distillation of coal, shale, iron-stone and organic substances.*"—"My invention has reference to the arrangements of retorts, and the application of heating substances, so that variation and gradual increase of temperature may be easily attained. The charging of retorts, and working off are effected in a successive manner, the internal and external heat being progressive, and under control of the operator, so as at will to be either increased or decreased. The retorts are arranged side by side, and back to back, in two long rows, the retorts being so connected as to form a continuous series,—or that the series in plan represents a flattened circle, or an oval. The retorts are worked in sets of two, three or more, the first retort of one set becoming, after working off, the last of the succeeding set, thus;—1, 2, 3, 4; 1, 2, 3, 4; 1, 2, 3, 4; second working 4, 1, 2, 3; 4, 1, 2, 3; 4, 1, 2, 3; third working 3, 4, 1, 2; 3, 4, 1, 2; 3, 4, 1, 2; and so on round the whole series. By reducing the number of retorts in each set from 4 to 2, I can increase the temperature of the set of retorts, and by increasing the number of retorts from 4 to 6, or 8, I can reduce the temperature of the set, the internal and external heating gases having a greater or less distance to travel, and a greater or less quantity of material to heat. As fuel for external heat, I prefer to use the gases generated in the retort after all the more valuable constituents have been removed, but I can use the residual coke or other fuel. There is provided a system or arrangement of taps, or valves and dampers, whereby I am enabled to supply the gas (mixed

with a due proportion of air and ignited) to the first retort of the set, making the heat thus generated pass round in succession the remaining retorts of the set, before escaping to the main flue. When the charge is finished, the gas is shut off from the first retort, which after being recharged, becomes the last of the succeeding set, and the gas being applied to the next in the set which now becomes the first. The gases are carried through the whole series before being condensed, one pipe sufficing for the gases from the whole set."

1883, April 28. No. 2149.

CROSSLEY, WILLIAM, of Glasgow, Lanark. (Provisional protection only.) "*Improvements in distilling shale and other minerals, to obtain oil and other useful products; and in apparatus therefor.*"—"In carrying out this invention the distillation is effected in a chamber or vessel which is not heated externally, but by means of steam which is very highly superheated, and is passed through and amongst the shale or other minerals. The distilling vessel may be of large size, is by preference of a vertical cylindrical form, and built of firebrick with an external iron shell or casing; and it is provided with a double valved hopper at the top for introducing the mineral in a practically continuous manner and with one or more doors or other suitable outlets at the bottom for withdrawing the earthy residues. With each distilling vessel there are combined two heaters or chambers for heating the steam, each of these being a cylindrical iron vessel lined with firebrick, and containing checkerwork or openly arranged firebricks or any suitable refractory heat storing material. Each heater is prepared for heating the steam by there being burned in it some of the permanent gases formed in the distillatory process or some combustible gas separately produced for the purpose, the necessary air for its combustion being admitted or forced into the heater along with the gas or by different inlets. When the interior of one heater is sufficiently hot the supply of gas and air is stopped, and steam from say an ordinary boiler may be passed into it. At the same time the gas and air are turned into the other heater and burned in it to prepare it to heat the steam, they being used alternately. The highly heated steam acts on the shale &c., and causes the evolution of vapours of oil, tar, ammonia and some permanent gas, and these products are led from the upper part of the apparatus to suitable condensers. In some cases it may be advantageous to pass some air into the vessel either with the steam or separately."

1883, July 23. No. 3604.

PATTINSON, HUGH LEE, of Felling, Durham. "*Improvements in apparatus for distilling coal or other like substances in order to obtain products therefrom.*"—The same as No. 553 of 1883, except that the retorts terminate at 7 feet from the base of producer instead of 9 feet.

1883, July 30. No. 3725.

IRVINE, CHARLES McLAREN, Blackwood, Lanark; and SLATER, ROBERT, of Blackheath, Kent. "*Improvements in the treatment of bituminous shales largely impregnated with sulphur and in obtaining products therefrom.*"—"Our invention relates to the treatment of shale containing large quantities of sulphur like the shales obtained from the oolite system present in large quantities in Kemmeridge in Dorsetshire. This shale has at present been distilled at a high temperature, its products being almost valueless whilst the foul smell given off in such process has become a public nuisance. By our invention we remedy this by using the sulphuretted compounds by obtaining sulphur and other marketable products by proceeding as follows:—We take such shale or shales containing large quantities of sulphur combined with the organic or inorganic matters present and distil such shales at a low heat (as used to treat ordinary oil yielding shales) without but preferably with the application of steam, and condense the watery and oily distillates in the usual manner. We then conduct from the retorts in which the distillation is effected the gases generated consisting of incondensable hydrocarbons and sulphur compounds principally sulphuretted hydrogen and treat them in one of the following ways: 1st. We simply burn the gases, and employ the sulphurous acid produced for the making of sulphuric acid in the usual well-known manner. 2nd. We mix sulphurous acid gaseous or in solution in water, with these gases containing sulphuretted hydrogen or sulphurous acid gas and steam, the result being their mutual decomposition and the formation of water and elimination of free sulphur. The necessary sulphurous acid may be obtained by burning a certain proportion of the gases containing the gases already described, and mixing the products of combustion (containing sulphurous acid) with the other portions of the gases produced from the distillation. By adopting this method we purify the hydro-carbons, and can utilize thus purified either for heating or lighting. 3rd. We employ oxides of iron such as are usually used for the purpose of

gas purification, which oxides absorb the sulphuretted hydrogen and fix the sulphur and we then employ it for the manufacture of sulphuric acid by first burning it to produce sulphurous acid and then combining it with nitric fumes."

1883, December 13. No. 5724.

COUPER, PETER, Edinburgh; and RAE, MARTIN, Middleton Hall, Linlithgow. "*Improvements in the distillation of coal, shale, and other carbonaceous substances yielding hydrocarbons and nitrogenous compounds, and in the apparatus or means employed therefor.*"—"This invention has for its objects the obtaining of high percentage products and to utilise the heat giving properties of the said substances prior to the unconsumable ash or earthy portions of them being discharged from the retort or distilling chamber. To effect this object there is formed below the retort a chamber, preferably of fire brick and of larger capacity for example twice, thrice, or a greater number of even capacities of the retort itself. At such times as it becomes necessary to recharge the retort, sufficient ash is withdrawn by means of a door in the under part of the chamber to allow the hot and partially exhausted charge in the retort to sink into the chamber preferably corresponding to the level corresponding to the top of the chamber. One or more jets of steam is or are admitted into the lower part of the enlarged distilling chamber and which are preferably arranged so as to draw in the quantity of air necessary for securing the combustion and distillation hereafter described. The retort constituting the upper part of this apparatus is heated partly from surrounding flues or any other suitable manner, and partly by heat escaping from the enlarged chamber below. The distillation continued in this lower chamber is not effected by means of flues or other outside heat but by the combustion conducted within the chamber itself and mainly of the organic matters remaining in the substance. It is preferable that this enlarged chamber be an even number of times the capacity of the retort, but not absolutely necessary. The products of distillation are withdrawn from the upper part of the retort."

1883, December 27. No. 5873.

HENDERSON, NORMAN M'FARLANE, Broxburn, Linlithgow. "*Improvements in obtaining oil and gas from minerals and in apparatus therefor.*"—"In carrying out the invention according to one modification vertical retorts are constructed in rows, two rows forming a



bench. When shale or other oil yielding material is being operated upon and the principal object is to obtain oil, the mineral is dealt with in the following manner in each pair of retorts. Fresh shale is filled into the retort at one side, and for a suitable time is subjected to a comparatively low temperature to obtain the oil in the best manner. When the material has become reduced to "spent shale" or coke, a much greater heat is applied to it and highly superheated steam is injected into it in order to decompose the coke and drive off most of the remaining carbon and the ammonia. At an interval of time equal to about one half the time occupied by the two stages of the treatment of the mineral in one retort, fresh shale is filled into the retort at the other side of the bench, and the highly heated gases and vapours produced by the 2nd process in the one retort are led through the fresh minerals in the other."

1884, April 8. No. 6094.

YOUNG, WILLIAM, of Priorsford, Peebles; and BEILBY, GEORGE THOMAS, of Mid Calder, Midlothian. "*Improvements in the distillation of mineral oils, and in the apparatus employed therefor.*"—"The guiding principles on which our process and arrangements are founded are (First) continuous distillation, (Second) the utilization of the heat from the fuel, employed to effect the distillation, in such a manner that the high temperature where the combustion is effective is made to distil the oils having a high boiling point, and that as the products of combustion lose heat by distilling the said oils they are made successively to distil the more volatile oils, so that by the time they reach the flue leading to the chimney stack the heat has been fully utilized; (Third) the separation of the oil vapours arising from the oils of different densities as they flow from the hotter end of the still; (Fourth) the conjoined heating and partial distillation of the oils on the way to the still, and the condensation of the oil vapours coming from the still in such a manner that the cold oil flowing to the still will first act as the condensing agent for the more volatile vapours from the still, and that as the oil becomes gradually heated, it will be made to act successively as the condensing medium of the heavier and less volatile vapours and by being thus heated and applied will act as a means of further fractionating the oils and at the same time conserve the heat of the oil vapours. The still which we employ to carry out the process of distillation embracing those essential features is so constructed that the oils which are to be distilled are made to flow in a tortuous manner

either horizontally or vertically by means of divisions in the still, and the vapours arising from the oils flowing in this tortuous manner are isolated in the different stages of the flow, by means of partitions hanging from the roof of the still and dipping into the oil, the oil vapours being drawn off and conveyed to the combined condensers by a still head and connecting pipe. The distillation may be continued for considerable periods when the oil is clear and nearly all volatile, but when the oils contain solid matters in suspension or solution, the residues must be drawn off from the still's last division whilst they are in a liquid state, and treated in separate residue stills. A still, having the aforesaid character, may be of various forms, but the form we find most convenient is a long cylinder of malleable iron built in brickwork in the usual manner, but having rollers or other provision to allow of the expansion due to the extra length. In cases where the oil has a tendency to deposit upon the walls of the still, the still may be built up of cast iron segments bolted together, and a stirrer may be made to rotate and keep the solid matters from being deposited. The still in whatever way constructed is heated so that the firegases travel along the bottom and sides of the still, in the opposite direction to the flow of the oil undergoing distillation. The best condenser and heater combined consists of a vessel containing a number of vertical tubes, fixed into the bottom of said vessel, underneath being a chamber to collect the condensed oils."

1884, April 8. No. 8409.

YOUNG, WILLIAM, of Priorsford, Peebles; and BEILBY, GEORGE THOMAS, Mid Calder. "*Improvements in the distillation of mineral oils, their residues, and tars, and in the apparatus employed therefor.*"—"The apparatus for carrying out this invention consists of a vessel containing a series of shelves or trays placed over each other, all being built of malleable or cast iron. The oils, their residues or tars are made to flow down from tray to tray of the arrangement, whilst a current of superheated steam is made to flow upwards and effect the distillation of the oils, their residues or tars. The trays are filled with broken materials such as iron balls, coke, &c., exposing a large surface."

1884, September 11. No. 12,286.

DOW, PETER, of Whitelees, Lanark. "*Improvements in retorts for distilling shale, coal, and other substances.*"—"The invention relates to the use of steam and air for distilling purposes in the vertical retorts,

in the lower part or chamber of such retorts. A vertical steam pipe is placed at the exterior of each retort, and such steam pipe is provided with a series of branches at different levels, each such branch having also upon it a valve or cock for opening or closing the admission of steam as required.—A further valve or cock is also provided in each case for opening or closing the admission of air. A spy hole with a shutter is also formed in the said retorts in the neighbourhood of the several branches for the purpose of inspecting the state of the material at different levels in the retort.”

1885, May 16. No. 6048.

AITKEN, HENRY, of Falkirk, Stirling. “*Improvements in the treatment of carbonaceous, bituminous, calcareous and other substances to obtain products therefrom.*”—“The invention consists in sending either all gaseous or volatile products, or a portion thereof, resulting from the substance undergoing combustion or distillation into the vessels or chambers themselves; or gaseous or combustible products obtained from an external source may be used. The gaseous products, by being wholly or partly burnt in the vessels or chambers, increase the temperature within the same and thus effect the distillation or burning in such vessels or chambers of substances which are not easily burnt or distilled by the heat produced therein by the introduction of air or steam or air. The gaseous products may be admitted to the chambers or vessels either mixed with the air or steam or air and steam or they may be admitted either at the same level or at one or several points either above or below that at which the air or steam or air and steam are admitted.”

1885, October 29. No. 13,014.

HENDERSON, NORMAN M'FARLANE, Broxburn, Linlithgow. “*Improvements in apparatus for distilling shale or other mineral oil or petroleum.*”—“In carrying out my invention the distilling processes are conducted in a continuous manner and so as to obtain more uniform results than when the oil is dealt with in separate and distinct charges. One form is what is known as a wagon shaped still for the primary one, and two secondary stills one each side of it of the same shape. The primary still is connected by pipes and stop-valves with the secondary stills; and each of these two are connected by pipes and stop valves, with two or more coking stills, which last are used in rotation, one being cleaned while the other is

in use. The primary and secondary stills are heated by furnaces built so that the legs or lateral deeper parts are built into walls and protected from the direct fire heat. The fire grate is preferably placed in a low position between the two walls carrying the still, the space above the grate and between it and the concave bottom of the still serving as a combustion chamber and tending to prevent smoke. From the combustion chamber the firegases pass along under the concavity of the still from the front end to the back end returning by flues at the sides and finally descending by vertical flues to underground flues leading to the chimney. In the primary still the oil operated on enters by a vertical feed pipe just dipping below the top surface of the oil, whilst in each secondary still, the oil enters by a horizontal feed pipe situated at a short distance above the top of the concavity of the still bottom, the feed pipe entering the still at one end, and delivering the oil at the other end. In such cases as a small quantity only being distilled the secondary stills may be abolished, the primary one connecting direct to the coking stills."

1886, November 15. No. 14,840.

YOUNG, JOHN, Stoke on Trent. "*Improvements in carbonising or distilling coal or shale.*"—"My invention consists in adding to the coal or shale, after it is placed in the retorts for distillation, common salt to the extent of 4 lbs. avoirdupois to every ton of coal, shale &c. The products resulting are much more easily freed from sulphur compounds; the ammoniacal products are increased in quantity."

1886, December 2. No. 15,772.

TENNENT, ROBERT BROWNE, Whifflet, Coatbridge, Lanark. "*Improvements in the destructive distillation of shale and other minerals and in retorts therefor.*"—"The improvements as applied to a bench of four or any greater number in a parallel row of close retorts, are arranged vertically, each preferably of a rectangular shape inside and outside in horizontal section, and having their walls mostly built of fireclay bricks of equal thickness throughout the body part, so as to be heated by flame flues surrounding this, which is strengthened by numerous odd bricks across the surrounding vertical flues to stay and keep the walls in proper shape. Each retort is formed or fitted with a cast iron filling or charging top case and mouth-piece built into the brickwork and extending down to the neck of the brick retort—the body part of which tapers or widens

out on all the four sides towards the bottom like an obelisk. From this straight wide part however the discharge end is curved at right angles to the body, within the strong basement brickwork and lower part of the main outer front walls enclosing the whole set of 4 or more retorts when they are extended in line. This curving out discharge end is cased with iron on the lower side, and contracted on the upper curved side towards a rectangular cast iron discharging mouth piece with ordinary closing and opening doors, and secured to the front walls on opposite sides, at a convenient height off the floor level to deliver the spent material. Each pair of retorts so constructed (preferably 8 to 12 times their width in height) are built back to back in the transverse direction, with their discharge lower ends curved or branching outwards on opposite sides from each other through their respective front side walls, and over their hot air and gas distributing and uniting flues and pipes ranged in the basement brickwork below each pair of retorts which they have to supply and heat."

1887, May 31. No. 7867.

FRASER, WILLIAM MILLIGAN, and SNODGRASS, JAMES, Pumphreston, Midlothian. "*Improvements in primary distilling apparatus for shale &c.*"—"Each retort on one side of a bench is dealt with as a pair with the retort adjacent to it on the other side of the bench and the lower brickwork parts of each pair of retorts are built of a form which is rectangular or approximately so in horizontal section, the compartments for the two retorts being separated from each other by a comparatively thin brickwork partition which has no flues passing through it. Flues are formed round the pair of lower parts for the passage of ignited gas to heat them, such gas finding its way into the oven space in which the upper part of the retorts are placed, and from thence finally to a chimney. In this way overheating the middle adjacent parts of the two lower retort spaces of a pair is avoided and the formation of clinker at those parts is prevented, whilst the ignited heating gas is better used on the three sides of each retort space. The heating is in effect more uniform across the retort spaces, the treatment of the material more equal and complete, and its descent more regular. The retorts at the same time are rendered more durable, whilst the cost for repairs and maintenance are lessened. These improvements are applicable to retorts at present in use, as well as in the building of new retorts."

1888, July 7. No. 9893.

JONES, JAMES, Dalmeny Oil Works, Linlithgow. "*Improvements in vertical or inclined retorts for distilling shale.*"—"One modification of the invention consists in constructing that portion of the underside of the discharge orifice or mouth piece more or less approximately flat or at a slightly obtuse angle with the vertical axis of the retort. Another way the discharge orifice is formed in a continuous incline from the line of its junction with the bottom of the retort to the discharge door."

1889, June 14. No. 9783.

INKERMAN, ALEXANDER NEILSON, Renfrew, and BLACK, WM., Stanrigg, Airdrie, Lanark. "*Improvements in distilling shale, coal &c. and in retorts.*"—"The improved retort or chamber is built of firebrick in the form of a large cylinder and preferably encased by a shell of sheet iron to exclude air. A hopper is fixed on the top, to which the sheet iron is securely jointed. A door or doors may also be jointed to the shell at the bottom for drawing off refuse from the retort. At or immediately above the lower doors a jet of steam is introduced, and also a supply of air, both of which may be regulated according to the heat required. The retorts may be built singly or in groups. The retort when applied to shale distillation for oil &c., is preferably built vertical and is of great height and large dimensions, and it may be oblong at the bottom, tapering slightly, and regularly, narrower towards the top. The action of the retort is practically continuous, a portion being drawn from the bottom, and a fresh portion charged at the top at regular intervals. The contents of one retort may be as much as 50 tons or more,  $\frac{1}{2}$  or thereabouts being drawn from it and an equal quantity added daily, thus ensuring the material to be under the action of the heated vapours or gases for 4 or 5 days. The outlet or outlets for vapours are at the top part of the retort. The partially spent shale is burnt at the bottom by the steam and air the hot vapours and gases from which pass up through the mass of fresh shale whereby the oil products are distilled under the most favourable circumstances. In cases where carbon is deficient in the spent material (to maintain the desired heat) a small quantity of coke-breeze, cinder, or anthracite coal may be charged along with the material being operated on."

1889, March 16. No. 4597.

YOUNG, WILLIAM, Priorsford, Peebles, and BEILBY, GEORGE THOMAS, Slateford, Midlothian. "*Improvements in the distillation of mineral oils and apparatus therefor.*"—"An arrangement suitable for the continuous distillation of oils when a high temperature has to be employed as with oils in a crude state or after their grosser impurities have been removed by a treatment with acid and alkali, consists of a vertical 'cylindrical' dome covered still composed of outer and inner shells of such dimensions that the annular space between them is just sufficiently wide to admit of access for cleaning. The whole shell is built of malleable iron or steel plates with the exception of the dome shaped crown of the inner shell which is the part exposed to the greatest heat and is preferably made of cast iron. The annular space between the shells is divided into compartments by horizontal partitions. These compartments communicate with each other and with the chamber between the outer and inner domes, by means of covered tubular openings which trap the vapours as they are evolved from the oil and allow them to pass up through the oil contained in the upper chamber. There are also other openings through the partition for the passage of the oil. These openings are arranged to cause the oil to travel in a circuitous course round the annular compartments and through the upper chamber. The residue is drawn off from the upper chamber into other stills in which it is distilled to dryness. Steam may be used to assist the distillation of the vapours, but in far less quantity than is generally used, because the more volatile oils partly serve the same purpose as steam. The oil vapours are condensed as explained in Patent No. 6094 of 1884. Stills constructed and worked in the above described manner may be worked in a series of two or more."

1889, June 24. No. 10,277.

DEWAR, JAMES, Cambridge; and REDWOOD, BOVERTON, Finchley. "*Improvements in the distillation of mineral oils and in apparatus for that purpose.*"—"We arrange a suitable boiler and a condenser in free communication with each other, without interposing any valve between them, but we provide a regulated outlet for condensed liquid from the condenser. We charge and keep charged the space in the boiler and condenser that is not occupied by liquid with gas under considerable pressure, it may be with air, but preferably with carbonic acid gas, or other gas that cannot act

chemically on the matter treated. The distillation and condensation being thus conducted under considerable pressure, which can be regulated at will, we obtain from heavy (petroleum) residuum a quantity of more or less light oil suitable for illuminating purposes, which cannot be obtained by distilling under atmospheric pressure. A suitable valve should be provided for drawing off any incondensable gases. We may also arrange the top part of the apparatus so as to 'crack' the oil, but at a high pressure instead of at atmospheric pressure as is usual."

1889, August 17. No. 13,016.

DEWAR, JAMES, and REDWOOD, BOVERTON. "*Improvements in distillation of mineral oils, and in apparatus therefor.*"—"To obtain heavy oils of high viscosity needing little subsequent purification we conduct the distillation under a regulated pressure lower than that of the atmosphere in a current of air or other gas that cannot act chemically on the matter treated, our arrangements being such that the distillation is continuous. The retort and 2 receiving vessels are all connected with an air pump. The retort is provided with the necessary pipes for the admission of the air or other gas, and also a pipe as an inlet for the oil to be distilled."

1889, October 31. No. 17,232.

HENDERSON, NORMAN M'FARLANE, Broxburn Works, Linlithgow.—"In my invention for distilling lubricating oils from residues &c. I employ a still of circular form in plan, having a hemispherical cast iron bottom with an upper part of wrought iron or steel and of an enlarged diameter. The still is supported on walls with the still bottom at some distance above the fire grate; and steam is superheated by the same fire, being passed through a coil of piping arranged round the upper part of the furnace space, such upper part being larger than the fuel space. The superheated steam passes into the still through a continuation of the piping, which inside of the still is arranged in coils two or three of which lie in a horizontal plane close to the bottom of the upper enlarged part of the still, and from these coils the piping is continued in two or three coils extending downwards near the sides of the lower part of the still which is of smaller diameter. From the end of the coils last



referred to the pipe is led upwards and out of the upper part of the still to regulating valves and thence again enters the still and proceeds nearly to the bottom where it issues among the oil and assists in the usual way. The steam is highly heated when first entering the still but in passing through the coil it yields part of its heat in an effective but non-injurious manner through the pipes to the oil, and when it finally enters openly amongst the oil its temperature has become suitably reduced. The various parts of the piping are provided with suitable valves externally so that steam can be led into the oil direct, as it is desirable to shut off the steam from the coils when the oil in the still has become lowered to a certain extent."

## INDEX.

- ABERCORN oil work, 17, 20  
Aberdeen, oil work at, 8, 20  
Acid burnt oil, 49  
— egg, 129  
— left in treated oils, 204  
— recovered (method of obtaining), 205  
— tar, 49, 128, 205  
— treatment, 49, 128  
— — caution for, 50  
— — theory of, 49  
— used for treatment, 49  
Addiewell, oil work at, 10, 20  
Agitation, air *versus* mechanical, 203  
— how to mitigate loss caused by air, 205  
— loss caused by air, 205  
Agitators, 126  
Air agitation, how to mitigate loss caused by, 205  
— — loss caused by, 205  
— — condenser, 54, 94  
— — naphtha, 94, 143  
— — — distillation, 99  
— — — yield, &c., of, 99  
— — semi-refined naphtha, 99, 143  
— — — treatment of, 143  
Airdrie Mineral Oil Co., 20  
Air *versus* mechanical agitation, 203  
Albyn oil work, 20  
Alkaline treatment, 49  
Allowance for temperature in measuring oils, 241  
Amalgamation of Clippen's Oil Co. and Midlothian Oil Co., 19, 22  
— of Young's Paraffin Light and Mineral Oil Co., and Uphall Oil Co., 16, 19  
Ammonia cracker boxes, 176  
— — — analysis of gases from, 187  
— from shale, theory of maximum production of, 46, 48  
— still, capacity of, 189  
— stills, old and new form of, 173  
— sulphate, apparatus used in manufacture of, 171  
— — chemistry of manufacture of, 183  
— — crystals, weight of, 190  
— — evaporating boxes, 179  
— — gravity of the acid used in the manufacture of, 188  
— — impurities in, 170  
— — liquor, gravity of, 187, 235  
— — — strength of, 187  
— — method of cheapening cost of manufacture of, 181  
— — pyrites, acid used in manufacture of, 184  
— — recovered pyrites, acid used in manufacture of, 185  
— — — sulphur, acid used in manufacture of, 183  
— — settling tanks, 178  
— — steam used in manufacture of, 190

- Ammonia sulphate, sulphur acid used in manufacture of, 49
- — uses of, 171
  - — working details of manufacture of, 179
  - water, 48, 169
  - — determination of ammonia in, 233
  - sulphate, determination of ammonia in, 234
  - water, discovery of value of, 169
  - — effect of oily basis on determination of ammonia in, 233
  - — special method for determining ammonia in, 233
  - — strength of, 188
  - — — of spent, 189
  - — sulphur in, 186
- Analysis of coke, 249
- of gas from retorts, 250
  - of sacking or press cloths, 250
- Arden oil work, 20
- Armadaile oil work, 20
- Auchenheath oil work, 20
- Auxiliary retort apparatus, 93
- Avonhead oil work, 20
- BAIN and Carlisle's oil work, 8
- Ballantine retorts, 12
- Bathgate oil work, 3, 20
- — Co., Limited, 17, 20
- Bathville oil work, 20
- Baxter and Macay's method of cooling, 150
- Beaumé degrees compared with specific gravity and Twaddell, 261
- Beilby's method of cooling, 151
- retorts, 81
  - — compared with Henderson and Vertical, yield of crude oil, &c., 83
  - — method of working, 82
  - — objectionable features of, 83
  - — principal features of, 83
- Bell, connection of, with distillation of shale, 4
- lease of shale fields, &c., 10
- Bell's horizontal retorts, 60
- Bellsquarry oil work, 20
- Benhar, oil works at, 9, 16, 20
- Benney, 11
- Binnend oil work, 17, 20
- Birkenshaw oil work, 20
- Blackburn, oil work at, 9, 20
- Blackston oil work, 20
- Black liquor, 7
- year of the oil trade, 19, 30
- Blue oil, 7
- Boghead coal, 3
- — price of, 6
  - — specific gravity of, 44
- Boiling point, apparatus used in the determination of, 236
- — determination of, 236
  - points of various shale products, 200
- Bridesholme oil work, 20
- Brown, Bros. & Co.'s oil work, 7
- Broxburn Oil Co., Limited, 16, 20, 30
- — work, 10, 20
- Buckside oil work, 22
- Burngrange oil work (Glasgow, Scottish Oil Co.), 14
- Burning oil, 137
- — boiling points, latent and specific heats and vapour densities of, 200
  - — lighthouse, 138
  - — marine, 138
  - — price of (1864), 11
  - oils, photometric tests of fractions of, 230
  - — stills, construction of, 121
  - — treated, 137
- Burntisland Oil Co., Limited, 17, 22, 30
- "Burnt" oil, 47
- CALEDONIA Mineral Oil Co., 19, 22

- Caledonia oil work, 22  
 Capeldrae oil work, 18, 22  
 Capital of the oil companies, 31  
 Capputhall Bog oil work, 22  
 Cambuslang Oil Co., 7  
 Carlisle and Co., 8  
 Carlowrie oil work, 22  
 Carrick and Arnot, 11  
 Champfleurie oil work, 18  
 Char used in wax refining, 165  
 Chrysene, 124  
 — preparation of, 251  
 Clyppins Oil Co., Limited, 17  
 — — — — amalgamation with Mid  
   Calder Oil Co., 19, 22  
 Clyppins oil work, 17, 22  
 Clydesdale Chemical Co., 7, 22  
 Coal, Boghead, price of, 6  
 — Coatbridge, yield of crude oil from,  
    14  
 — Methyl, yield of crude oil from,  
    12  
 — Parrot, 11  
 — Pirnie, 11  
 Coatbridge oil work, 14  
 Cobbinshaw oil work, 18, 22  
 Coefficient of expansion, 117, 241  
 Cold test and percentage of wax, rela-  
    tion between, 217  
 — — and viscosity, relation between,  
    221  
 — — how to determine, 215  
 Coke, analysis of, 249  
 — soda, 210  
 — — recovery of soda from, 210  
 — tower, 54  
 — — amount of oil circulated  
    through, 106  
 — — apparatus *versus* compression,  
    107  
 — — construction and method of  
    working, 100  
 — — naphtha, 102, 143  
 — — — apparatus, fuel required for  
    working, 106  
 — — — — William Young's, 107  
 Coke tower naphtha, condenser, 105  
 — — — heater, 104  
 — — — still, 105  
 — — — yield of, 107  
 — why and how formed, 52  
 — yield of, 125  
 Coleman's method of extracting  
    naphtha from retort gases, 106  
 Compounded or mixed oils, 230  
 — — — — test for fatty oil in, 231  
 — — — — test for minerals in, 232  
 — — — — test for rosin oil in, 232  
 — — — — test for wax in, 231  
 Compression *versus* absorption, 107  
 Condenser for retorts, *see* Air Con-  
    denser  
 — for stills, calculation for size of,  
    199  
 — — — calculations for water re-  
    quired for, 201  
 — — — danger from too long cooling,  
    119  
 — — — regulation of water supply  
    for, 119  
 — laboratory, 239  
 — worms, calculations for size of,  
    199  
 Conepark oil work, 22  
 Contract of copartnership between  
    Young, Meldrum and Benney, 5  
 Continuous distillation, bad features  
    of, 198  
 — — Henderson's method, 198  
 — — of shale in ovens, yield from,  
    7  
 Cooling, Beilby's method of, 151  
 — crystallisation affected by method  
    of, 53, 153  
 — cylinder, 148  
 — drum, Young's, 147  
 — Henderson's method of, 153  
 — Macay and Baxter's method of, 150  
 — McCutcheon's method of, 153  
 — pond for spent shale, 108  
 Cowan's horizontal retort, 60  
 Cracker boxes, 176

- Cracker boxes, oily bases from, 187
- Cracking caused by distillation, demonstration of, 51
- oil by pressure, 195
- — by use of a column, 196
- — by use of a column, fallacy of, 197
- Craigie oil work, 22
- Crofthead oil work, 7, 22
- Crownpoint oil work, 22
- Crude oil, danger from water in, 116
- — expansion of, 117
- oils, characteristics and impurities of, 48, 123
- — from various retorts, 123
- — — shales, 123
- — laboratory purification of, 237
- — — corrections necessary for, 245
- — — details of, 241
- — necessity for being free from dirt and water, 116
- — products from, 124
- — stills, *see* Stills
- — theory of refining, 48
- — where first obtained in England, 2
- Crude scale, 140
- Crystallisation affected by mode of cooling, 53, 153
- promoted by distillation, proof of, 52
- DALMENY Oil Co., Limited, 16, 22
- Deans oil work (Westlothian Oil Co., Limited), 18
- Debentures and loans compared with original capital, 30
- Dennet and Brown oil work, 15
- Dennet shale, 15
- Depreciation of share values, 32
- Distillation, cracking caused by, 51
- crystallisation promoted by, 52
- of oils, impurities separated by 51
- Distillation of oils, the functions of, 51
- of shale, general outline of, 54
- regulation of, by steam, 118
- *versus* acid and soda treatment, 248
- Distilling, 110
- data (Chapter VI.), 191
- Dougal's oil work, 9
- Drumcross oil work, 22
- Drumgray oil work, 22
- Dryflat oil work, 22
- EARLY method of extracting wax, 155
- East Fulton oil work, 22
- Eggs for acid, 129
- Explosion doors for retort gas mains, 92
- FAMOUS lawsuit, 7
- Fatty oils, tests for, 231
- Fauld's oil work, 10
- Fell's oil work, 9
- Fergushill oil work, 22
- Fernie's oil work, 18
- Filter press, 156
- Financial losses, 30, 32
- — cause of, 33
- — excuses for, 33
- First manufacturer of oil from Boghead coal, 1
- Finished liquor, 7
- First stage oil stills, method of fractionating distillate from, 132
- — — treatment of, 133
- Flash point of lubricating oils, method of determining, 219
- points, how to determine, 218
- Fourth stage oil stills, method of fractionating distillate from, 139
- Fuel for coke tower naphtha apparatus, 106

- Fuel for Henderson retorts, 71  
 — — vertical retorts, 68
- GALLETLY'S connection paraffin wax, 6  
 — improved retort, 68  
 — improvement on Kirk's vertical retort, 68
- Gas, fallacy of extracting all naphtha from, 68  
 — from air condensers, temperature of, 100  
 — — Henderson retorts, analysis of, 250  
 — — — — volume of, 106  
 — — stills, 125  
 — — Young and Beilby's retorts, volume of, 106
- Gasoline, boiling point, latent and specific heats and vapour density of, 200  
 — preparation of, 143  
 — still, 143  
 — — method of fractioning distillate from, 145
- Geographical and geological (Chapter II.), 38
- Glasgow Scottish Oil Co., 14, 22
- Glenture oil work, 22
- Grange oil work, 22  
 — Pans oil work, 22
- Greendykes oil work, 22
- Greengairs oil work, 22
- Green liquor, 7
- Greenshields & Co.'s oil work, 17
- Griffith's retorts, 14
- HARTHILL oil work, 9, 22
- Hernand Oil Co., 22  
 — — — amalgamation with Walkinshaw Oil Co., 19  
 — — work (Dennet and Brown), 15, 22
- Heavy oils and wax, method of extracting wax from, 140
- Heavy residuum stills, method of fractionating distillate from, 139
- Henderson's method of continuous distillation, 198  
 — — of continuous distillation, and features of, 198  
 — — of cooling, 150  
 — retorts, *see* Retorts  
 — sweating apparatus, 163
- High Possil oil work, 22
- Holmes Oil Co., Limited, 18, 22, 30
- Horizontal retort, large size D, 60  
 — — setting, 61  
 — retorts, *see* Retorts
- Hurlford oil work, 22
- Hutches, 56
- Huchinson's oil work, 24
- Hydraulic press, 155
- Hydrocarbons, 46
- INJECTORS for burning oil, 187
- Inkerman oil work, 17, 26
- Inverkeithen Oil Works Co., 9, 24  
 — retorts, 12
- JOHNSTONE oil work, 17
- KILWINNING oil work, 24
- KIRK'S vertical retort, *see* Retorts
- Kirkwood, oil work at, 14, 24
- LABORATORY and works results, difference between, 249  
 — (Chapter VIII.), 214  
 — cold press, 239  
 — condenser, 237  
 — purification, corrections necessary for, 245  
 — — details of, 241  
 — — form for reporting results, 247  
 — — of crude oil, 237  
 — still, 237

- Laboratory vise press, 238, 239  
 Lanark Oil Co., Limited, 18, 19, 24  
 Lanark oil work, 24  
 Lanemark oil work, 24  
 Latent heat of oils, 200  
 Leavenseat oil work, 24  
 Lighthouse burning oil, 138  
 Limerigg oil work, 24  
 Linlithgow Oil Co., Limited, 18, 24  
 — — — — losses of, 30  
 Livingstone's (Dr.) connection with  
   Addiewell works, 11  
 Loans and debentures compared with  
   original capital, 30  
 Lochgelly oil work, 24  
 Low Possil oil work, 24  
 Lubricating oil distillates, 142  
 — — specific heat of, 200  
 — — treatment, 142  
 — oils, method of raising flash point  
   of, 142
- MACAY and Baxter's method of cool-  
   ing, 150  
 Marine burning oil, 138  
 McBeath's retort, 69  
 McCutcheon's cooler, 153  
 — proposal for cheapening cost of  
   steam for retorts, 93  
 — steam superheater for stills, 114  
 McLagan's Oil Works, 14  
 Meldrum, 2  
 Melting points, determination of,  
   223.  
 — — of crude scale, 140  
 — — of mixtures of wax, calcula-  
   tions for, 224  
 — — of mixtures of wax and  
   stearine, 225  
 — — of stearine, peculiarity of, 224  
 Methyl coal, *see* Coal  
 Methyl Paraffin Oil Co., 24  
 — paraffin oil work, 11  
 Midcalder Oil Co., 15, 24.  
 Midlothian Oil Co., Limited, 17, 24  
 — — — — amalgamation with Clip-  
   pens, 19  
 Millburn oil work, 18, 24  
 Miller & Son's oil work, 8
- NAPHTHA from air condenser, *see*  
   Air condenser  
 — treatment, &c., 143  
 Nimmo & Son's oil work, 12  
 Normal paraffins, boiling points of, 259  
 — — chemical formulæ of, 260  
 — — preparation of, 257  
 North British Oil and Candle Co., 12,  
   24
- OAKBANK Oil Co., Limited, 15, 24  
 — — work, 8, 24  
 Oil burners, 187  
 Oil in wax, determination of, 228  
 — traps, 210  
 — Companies, list of, with dates, &c.,  
   20  
 — — total number that have been  
   in existence, 28  
 Oily bases, 49  
 — — effect of, on oils, 50  
 — — extraction of, 256  
 — — from cracker boxes, 187  
 Olefines, 49, 52  
 Old Monkland oil work, 24  
 Once run oil or distillate, 124  
 — — — treatment, 131  
 Origin of Scotch oil trade, 1  
 — of shale oil industry, 3  
 Over Possil oil work, 24
- PAGE & Co.'s oil work, 24  
 Paraffin oil work, 24  
 — wax, *see* Wax  
 Paraffins, normal, *see* Normal paraf-  
   fins  
 Pathhead oil work, 24

- Paul and Grey's oil work, 9, 24  
 Pentland oil work, 17, 24  
 — Retorts, *see* Retorts, Young and Beilby  
 Phenols, 49  
 — effect on oils, 50  
 — extraction of, 253  
 Philipstoun oil work, 18, 24  
 Photometric tests of burning oil fractions, 230  
 Port Dundas oil work, 24  
 Practical (Chapter IV.), 54  
 Press cloths, analysis of, 250  
 — filter, 156  
 — hydraulic, 155  
 — laboratory, 239  
 Pressed oil, treatment of, 141  
 Pressing, 146  
 — theory of, 159  
 Pressure stills, *see* Stills  
 Products from crude oil, 124  
 — — shale, 97  
 Pumpherston Oil Co., Limited, 18, 24  
 — — Co.'s losses, 30
- RECOVERED acid, 205  
 — — method of obtaining, 205  
 — soda, 206  
 Residuum stills, method of fractionating, 139  
 Refining, 110  
 — theory of, 48  
 Relations between cold test and viscosity, 221  
 — — specific gravity and viscosity, 221  
 Retort condensers, *see* Air condensers  
 Retorting, fallacy of too long, 78  
 — first advancements in, 68  
 — special advancement in, 71  
 — theory of, 46  
 — *v.* refining, improvements in, 28  
 Retorts, amount of vacuum in gas mains, 94  
 — auxiliary apparatus, 93
- Retorts, Ballantine's, 12  
 — Beilby's, 81  
 — — method of working, 82  
 — — objectionable features of, 83  
 — — principal features of, 83  
 — — yields, &c., from, compared with Henderson's and vertical, 83  
 — Bell's horizontal, 60  
 — Cowan's horizontal, 60  
 — explosion doors for gas mains of, 92  
 — forms of, first used, 5  
 — gas from, *see* Gas  
 — Griffith's, 14  
 — Henderson, improvement in heating, 76  
 — — fallacy in using spent shale as fuel in, 75  
 — — favourable features of, 76  
 — — fuel from, 74  
 — — hourly yield from, 77  
 — — labour required, 74  
 — — life of, 78  
 — — method of working, 72  
 — — objectionable features of, 76  
 — — reduction of fuel for, 76  
 — — shale charges for, 78  
 — — strength of ammonia water from, 189  
 — — *versus* vertical, comparison of yields, &c., from, 79  
 — horizontal *versus* vertical, cost of working, 62  
 — — — — market values of products from, 63  
 — — — — yield of finished products from, 63  
 — — — — yields of crude oil, &c., from, 62  
 — Inverkeithen's, 12  
 — Kirk's vertical, 59, 64  
 — — — Galletly's improvement of, 68  
 — — — method of working, 64  
 — large sized D horizontal, 60



- Retorts, McBeath's, 69  
 — method of charging, 57  
 — result of using steam in, 67  
 — setting for horizontal, 61  
 — vertical, capacity of, 66  
 — — fuel used in, 68  
 — — labour required, 74  
 — — life of, 68  
 — — shale charges for, 66  
 — — *versus* Henderson, 79  
 — — *versus* horizontal, *see* Retorts,  
     horizontal *versus* vertical  
 — Young and Beilby's, 84  
 — — — claims made for, 86  
 — — — coal, 87  
 — — — cost of working, 90  
 — — — erroneously reported large  
     yields of ammonia  
     from, 91  
 — — — exceptional size of, 89  
 — — — hazardous working of,  
     89  
 — — — life of, 89  
 — — — McCutcheon's proposal  
     for cheapening cost of  
     steam used in, 93  
 — — — shale charges for, 89  
 — — — special novelty, 87  
 — — — *versus* Henderson's, steam  
     used in, 93  
 — — — strength of ammonia  
     water from, 189  
 — — — *v.* Henderson's, yields of  
     crude oil, &c. from, 90  
 — — — *v.* Henderson's, yields of  
     finished products from,  
     90  
 — — — *v.* Henderson's, yields of  
     scale and lubricating  
     oil from, 91  
 — Young's horizontal D, 57  
 — — vertical, 58  
 — — — faults in, 58  
 — — — improved, 58  
 — when steam was first used in, 67  
 Riggend chemical and oil work, 24  
 Roachsole's oil work, 24  
 Rosin oil, test for, 232  
 Ross oil work, 24  
 Ross & Co. (Philipstoun oil work),  
     18, 24  
 Roughcraig oil work, 24  
 Rowatt and Youll oil work, 24
- SACKING, analysis of, 250  
 Scale, crude, 140  
 — — early methods of extracting,  
     155  
 — — melting points of, 140  
 — — determination of dirt in, 228  
 — — of oil in, 228  
 — — of water in, 229  
 Scottish Mineral Oil Association, 34  
 Seafield, oil works at, 17  
 Second stage oil stills, method of  
     fractionating distillate  
     from, 133  
 — — — treatment, 135  
 Secret oil work, 6  
 Separator for oil and water, 97  
 Setting point, 215  
 — — and percentage of wax, relation  
     between, 217  
 — — and viscosity, relation between,  
     221  
 Sevinhill oil work, 26  
 Sosewell oil work, 24  
 Shale and coal, difference between,  
     41  
 — breaker, 54  
 — — why used, 55  
 — chemical composition of, 45  
 — cooling pond for spent, 108  
 — curly, 42  
 — Dennet, 15  
 — distillation, general outlines of,  
     54  
 — distilled per annum, 28  
 — fields, boundaries of, 38  
 — leafy or scaly, 42  
 — plain, 42

- Shale oil manufacture, diagram of, 166
- products from, 97
  - proof that oil does not exist in, 46
  - relative yields from, 168
  - seams, names of principal, 40
  - — sectional diagram of, 39
  - — sectional diagram of, references to, 40
  - — thickness of principal, 40
  - theory of distillation of, 46, 48
- Shales, chemical composition of spent, 45, 48
- specific gravity of, 44
  - widely diverging characters of, 42
  - yields of crude oil from, 42
- Shand's oil work, 26
- Shareholders' poor prospects, 30
- Shares, depreciation in, 32
- Shettleston Oil and Chemical Company, 26, 32
- Shott's oil work, 12, 26
- Simpson's oil work (Benhar), 9, 16
- — — (Oakbank), 8
  - — — (Uphall and Sterlaw), 14
- Smith Brothers and Murling, oil work, 18
- Soda coke, *see* Coke
- recovery, cylinder process, 206
  - — tower process, 208
  - stills, method of fractionating, 141
  - tar, 49, 126
  - — recovery of soda from, 206
  - — cost of apparatus, 209
- Solidifying point, 214
- Specific heat, &c. of shale products, 200
- gravity compared with Twd. and Bé., 261
- Spent ammonia water, 189
- shale, 45, 48
- Standard Oil Co., 33
- Stannig oil work, 26
- Stearates, test for, 232
- Stearine, determination of melting point of, 224
- melting points of admixtures of, with wax, 225
- Steam, *see* Retorts and Stills
- Steel's oil work, 10
- Sterlaw Oil Co., 26
- oil work, 15, 26
- Stewartfield oil work, 26
- Stewart's oil work, 26
- Still-ends, *see* Chrysene
- Stills, first stage, method of fractionating distillate from, 132
- second stage, method of fractionating distillate from, 133
  - third stage heavy, method of fractionating distillate from, 136
  - — — light oil, method of fractionating distillate from, 135
  - fourth stage, method of fractionating distillate from, 139
  - ammonia, 173
  - burning oil, construction of, 121
  - capacity of, steam and labourers relating to, 195
  - condenser, danger from too long cooling, 119
  - — regulation of water supply for, 119
  - crude and heavy oil, 112
  - feed, 133
  - forms of, first used, 110
  - gas from, 125
  - gasoline, 143
  - — method of fractionating distillate from, 145
  - gradual improvements in, 110
  - heavy residuum, 139
  - laboratory, 237
  - lives, &c. of, 191
  - or worm house, 121
  - pressure, 195
  - — construction of, 195
  - — method of working, 196
  - — yields from, 196

- regulation of distillation by steam, 118  
 to be left for expansion when charging, 117  
 separators used in connection with, 116  
 soda, method of fractionating distillate from, 141  
 steam used in, 112, 193  
 steam used in, McCutcheon's method of superheating, 115  
   — in, methods of superheating, 114  
 Standard Oil Co., Limited, 17, 26  
 Sulfur oil work, 26  
 Taylor's oil work, 26  
 Tinning process for wax refining, 163  
 Henderson's, 163
- see* Acid and Soda tar  
 Taylor's oil work, 26  
 Technical, general (Chapter III),
- first stage heavy oil stills, method of fractionating distillate from, 136  
 light oil stills, method of fractionating distillate from, 135  
 limestone oil work, 26  
 Limestone mineral, 3  
 for oil, 210  
 Limestone oils, acid left in, 204  
 Limestone, acid used in, 49  
 Limestone, centrifugal stirrer for, 127  
 Limestone, old and present styles of, 126  
   *versus* mechanical agitation, 203  
 Limestone, for, 50  
 Limestone (Chapter VII.), 203  
 Limestone, theory of, 49, 126  
   *versus* distillation, 248  
 Limestone, treatment of first stage oils, 133  
 second stage oils, 135
- Treatment, of burning oil, 137  
   — of coke tower naphtha, 143  
   — of lubricating oil, 142  
   — of oils, *modus operandi*, 128  
   — of once run oil, 131  
   — of pressed oil, 141  
   — of semi-refined air-condenser naphtha, 143  
   — of small *v.* large quantities, 130  
   — *v.* distillation, 110  
 Twaddell degrees compared with Beaumé and specific gravity, 261
- UDDINGSTON Oil Co., 26  
 UPHALL Oil Co., amalgamation of, with Young's Co., 16, 19  
   — — — Limited, 16, 26  
   — oil work, 14, 26
- VACUUM in gas mains of retorts, 94  
 VAPOUR density of shale oils, 200  
 Vaseline, 52  
 Viscosity, effect of heat on, 222  
   — how to determine, 220  
   — relation between specific gravity and, 221  
 Vulcan oil work, 26
- WATER discharge from works, incident connected with, 212  
 Waterford Oil Co., 14  
 Wax, dirt in, 228  
   — how extracted, 146  
   — refined, 162  
   — refining, 160  
   — — by acid and soda, 160  
   — — by naphtha, 160  
   — — by sweating, 163  
   — — char used in, 165  
   — — char, when first used for, 165  
   — *see* Scale  
   — semi-refined, 162  
   — water in, 229

- Wax, when first separated, 6  
 — when first used as article of commerce, 6
- Waxes, causes of differences between, 52  
 — different characteristics of, 53  
 — specific heat of, 200  
 — specific gravity of, 250
- Walkinshaw Oil Co., Limited, 17, 26  
 — — — amalgamation of, with Hermand Oil Co., 19
- Water discharge from works, 210
- Waterford oil work, 14
- West Calder Oil Co., 9, 26
- Westfield Oil Co., Limited, 18, 26
- Westlothian Oil Co., Limited, 18, 26
- Whiterigg oil work, 26
- YIELDS, see Crude oil, Ammonia and Retorts
- Young and Beilby's retorts, a Retorts  
 — Jas., life of, 1
- Young, Meldrum and Bennie, contract of copartnership between, 5
- Young's cooling drum, 147  
 — (Jas.) retorts, 57, 58  
 — Paraffin Light and Mineral Oil Co., Limited, 12, 26  
 Amalgamation with Upland Oil Co., 16, 19  
 losses, 30
- (Wm.) coke tower naphtha apparatus, 107

1896.

BOOKS RELATING  
TO  
APPLIED SCIENCE

PUBLISHED BY

E. & F. N. SPON.

LONDON: 125 STRAND.

NEW YORK: 12 CORTLANDT STREET.

**Algebra.**—*Algebra Self-Taught.* By W. P. HIGGS, M.A., D.Sc., LL.D., Assoc. Inst. C.E., Author of 'A Handbook of the Differential Calculus,' etc. Second edition, crown 8vo, cloth, 2s. 6d.

CONTENTS :

Symbols and the Signs of Operation—The Equation and the Unknown Quantity—Positive and Negative Quantities—Multiplication—Involution—Exponents—Negative Exponents—Roots, and the Use of Exponents as Logarithms—Logarithms—Tables of Logarithms and Proportionate Parts—Transformation of System of Logarithms—Common Uses of Common Logarithms—Compound Multiplication and the Binomial Theorem—Division, Fractions, and Ratio—Continued Proportion—The Series and the Summation of the Series—Limit of Series—Square and Cube Roots—Equations—List of Formulae, etc.

**Architects' Handbook.**—*A Handbook of Formulae, Tables and Memoranda, for Architectural Surveyors and others engaged in Building.* By J. T. HURST, C.E. Fourteenth edition, royal 32mo, roan, 5s.

"It is no disparagement to the many excellent publications we refer to, to say that in our opinion this little pocket-book of Hurst's is the very best of them all, without any exception. It would be useless to attempt a recapitulation of the contents, for it appears to contain almost everything that anyone connected with building could require, and, best of all, made up in a compact form for carrying in the pocket, measuring only 5 in. by 3 in., and about  $\frac{1}{4}$  in. thick, in a limp cover. We congratulate the author on the success of his laborious and practically compiled little book, which has received unqualified and deserved praise from every professional person to whom we have shown it."—*The Dublin Builder.*

**Architecture.**—*Town and Country Mansions and Suburban Houses,* with Notes on the Sanitary and Artistic Construction of Houses, illustrated by 30 plates, containing Plans, Elevations, Perspectives, and Interior Views of Executed Works in the Queen Anne, Classic, Old English, Adams, Jacobean, Louis XVI., and other Styles. By WILLIAM YOUNG, Author of 'Picturesque Architectural Studies.' Imp. 4to, cloth, 10s. 6d.

A

- Architecture.**—*The Seven Periods of English Architecture*, defined and illustrated. By EDMUND SHARPE, M.A., Architect. 20 steel engravings and 7 woodcuts, third edition, royal 8vo, cloth, 12s. 6d.
- Baths.**—*The Turkish Bath: its Design and Construction for Public and Commercial Purposes.* By R. O. ALLSOP, Architect. With plans and sections, 8vo, cloth, 6s.
- Baths and Wash Houses.**—*Public Baths and Wash Houses.* By ROBERT OWEN ALLSOP, Architect, Author of 'The Turkish Bath,' &c. With cuts and folding plates, demy 8vo, cloth, 6s.
- Belting.**—*Belt Driving.* By GEORGE HALLIDAY, Whitworth Scholar. With plates, 8vo, cloth, 3s. 6d.
- CONTENTS :
- Description of different Kinds of Belts—Pressure transmitted by Belts—Length of Belt and Coned Pulleys—Stretching of Belts—V Pulleys—Arms of Pulleys—Methods of Use of the Belt discussed—Rope Gearing—Tables—Rules for finding the Pitch of Spur-Wheels.
- Blasting.**—*Rock Blasting: a Practical Treatise on the means employed in Blasting Rocks for Industrial Purposes.* By G. G. ANDRÉ, F.G.S., Assoc. Inst. C.E. With 56 illustrations and 12 plates, 8vo, cloth, 5s.
- Boilers.**—*A Pocket-Book for Boiler Makers and Steam Users*, comprising a variety of useful information for Employer and Workman, Government Inspectors, Board of Trade Surveyors, Engineers in charge of Works and Slips, Foremen of Manufactories, and the general Steam-using Public. By MAURICE JOHN SEXTON. Fourth edition, enlarged, royal 32mo, roan, gilt edges, 5s.
- Boilers.**—*The Boiler-Maker's & Iron Ship-Builder's Companion*, comprising a series of original and carefully calculated tables, of the utmost utility to persons interested in the iron trades. By JAMES FODEN, author of 'Mechanical Tables,' etc. Second edition, revised, with illustrations, crown 8vo, cloth, 5s.
- Brass Founding.**—*The Practical Brass and Iron-Founder's Guide*, a Treatise on the Art of Brass Founding, Moulding, the Metals and their Alloys, etc. By JAMES LARKIN. New edition, revised and greatly enlarged, crown 8vo, cloth, 10s. 6d.
- Breweries.**—*Breweries and Maltings: their Arrangement, Construction, Machinery, and Plant.* By G. SCAMMELL, F.R.I.B.A. Second edition, revised, enlarged, and partly rewritten. By F. COLYER, M.I.C.E., M.I.M.E. With 20 plates, 8vo, cloth, 12s. 6d.

**Bridges.**—*Plate Girder Railway Bridges.* By MAURICE FITZMAURICE, B.A., B.E., Mem. Inst. C.E. *Plates*, 8vo, cloth, 6s.

## CONTENTS :

Formule and Tables of Loads and Weights for Plate Girder Bridges, with Remarks on the allowable Working Stresses to be adopted in Steel and Iron—The Market sizes of Plates and Bars, and the different kinds of Bridge floors, with examples worked out in detail.

**Bridges.**—*Elementary Theory and Calculation of Iron Bridges and Roofs.* By AUGUST RITTER, Ph.D., Professor at the Polytechnic School at Aix-la-Chapelle. Translated from the third German edition, by H. R. SANKEY, Capt. R.E. *With 500 illustrations*, 8vo, cloth, 15s.

**Bridges.**—*Stresses in Girder and Roof Trusses for both Dead and Live Loads by Simple Multiplication*, with Stress Constants for 100 cases, for the use of Civil and Mechanical Engineers, Architects and Draughtsmen. By F. R. JOHNSON, Assoc. M. Inst. C.E. Part I, Girders. Part 2, Roofs. In 1 vol., crown 8vo, cloth, 6s.

**Builders' Price Book.**—*Spons' Architects' and Builders' Price Book, with useful Memoranda.* By W. YOUNG. Crown 8vo, cloth, red edges, 3s. 6d. *Published annually.*

**Building.**—*The Clerk of Works: a Vade-Mecum* for all engaged in the Superintendence of Building Operations. By G. G. HOSKINS, F.R.I.B.A. Third edition, fcap. 8vo, cloth, 1s. 6d.

**Building.**—*The Builder's Clerk: a Guide to the Management of a Builder's Business.* By THOMAS BALES. Fcap. 8vo, cloth, 1s. 6d.

**Canals.**—*Waterways and Water Transport in Different Countries.* With a description of the Panama, Suez, Manchester, Nicaraguan, and other Canals. By J. STEPHEN JEANS, Author of 'England's Supremacy,' 'Railway Problems,' &c. *Numerous illustrations*, 8vo, cloth, 14s.

**Carpentry.**—*The Elementary Principles of Carpentry.* By THOMAS TREGOLD. Revised from the original edition, and partly re-written, by JOHN THOMAS HURST. Contained in 517 pages of letterpress, and *illustrated with 48 plates and 150 wood engravings*. Sixth edition, reprinted from the third, crown 8vo, cloth, 12s. 6d.

Section I. On the Equality and Distribution of Forces—Section II. Resistance of Timber—Section III. Construction of Floors—Section IV. Construction of Roofs—Section V. Construction of Domes and Cupolas—Section VI. Construction of Partitions—Section VII. Scaffolds, Staging, and Gentries—Section VIII. Construction of Centres for Bridges—Section IX. Cofferdams, Shoring, and Strutting—Section X. Wooden Bridges and Viaducts—Section XI. Joints, Straps, and other Fastenings—Section XII. Timber.

**Chemistry.**—*Practical Work in Organic Chemistry.*

By F. W. STREATFIELD, F.I.C., etc., Demonstrator of Chemistry at the City and Guilds of London Institutes Technical College, Finsbury. With a Prefatory Notice by Professor R. MELDOLA, F.R.S., F.I.C. Crown 8vo, cloth, 3s.

**Chemists' Pocket Book.**—*A Pocket-Book for*

*Chemists, Chemical Manufacturers, Metallurgists, Dyers, Distillers, Brewers, Sugar Refiners, Photographers, Students, etc., etc.* By THOMAS BAYLEY, Assoc. R.C. Sc. Ireland, Analytical and Consulting Chemist and Assayer. Fifth edition, 481 pp., royal 32mo, roan, gilt edges, 5s.

## SYNOPSIS OF CONTENTS :

Atomic Weights and Factors—Useful Data—Chemical Calculations—Rules for Indirect Analysis—Weights and Measures—Thermometers and Barometers—Chemical Physics—Boiling Points, etc.—Solubility of Substances—Methods of Obtaining Specific Gravity—Conversion of Hydrometers—Strength of Solutions by Specific Gravity—Analysis—Gas Analysis—Water Analysis—Qualitative Analysis and Reactions—Volumetric Analysis—Manipulation—Mineralogy—Assaying—Alcohol—Beer—Sugar—Miscellaneous Technological matter relating to Potash, Soda, Sulphuric Acid, Chlorine, Tar Products, Petroleum, Milk, Tallow, Photography, Prices, Wages, Appendix, etc., etc.

**Coffee Cultivation.**—*Coffee: its Culture and*

*Commerce in all Countries.* Edited by C. G. WARNFORD LOCK, F.L.S. Crown 8vo, cloth, 12s. 6d.

A practical handbook for the Planter, treating in a thoroughly practical manner on the cultivation of the Plant, the management of an estate, Diseases and enemies of the Coffee Plant (with their prevention and cure), preparation of the berry for market, and statistics of local details of culture and production. Bibliography.

**Concrete.**—*Notes on Concrete and Works in Con-*

*crete*; especially written to assist those engaged upon Public Works. By JOHN NEWMAN, Assoc. Mem. Inst. C.E. Second edition, revised and enlarged, crown 8vo, cloth, 6s.

**Coppersmithing.**—*Art of Coppersmithing:* a

Practical Treatise on Working Sheet Copper into all Forms. By JOHN FULLER, Sen. *Numerous engravings*, illustrating almost every branch of the Art. Royal 8vo, cloth, 12s. 6d.

**Depreciation of Factories.**—*The Depreciation*

*of Factories and their Valuation.* By EWING MATHESON, Mem. Inst. C.E. Second edition, revised, with an Introduction by W. C. JACKSON, Member of the Council of the Institute of Chartered Accountants. 8vo, cloth, 7s. 6d.

**Drainage.**—*The Drainage of Fens and Low Lands*

*by Gravitation and Steam Power.* By W. H. WHEELER, M. Inst. C.E. *With plates*, 8vo, cloth, 12s. 6d.

**Drawing.**—*Hints on Architectural Draughtsman-*

*ship.* By G. W. TUXFORD HALLATT. Fcap. 8vo, cloth, 1s. 6d.



**Drawing.**—*The Draughtsman's Handbook of Plan and Map Drawing*; including instructions for the preparation of Engineering, Architectural, and Mechanical Drawings. *With numerous illustrations in the text, and 33 plates (15 printed in colours).* By G. G. ANDRÉ, F.G.S., Assoc. Inst. C.E. 4to, cloth, 9s.

**Drawing Instruments.**—*A Descriptive Treatise on Mathematical Drawing Instruments*: their construction, uses, qualities, selection, preservation, and suggestions for improvements, with hints upon Drawing and Colouring. By W. F. STANLEY, M.R.I. Sixth edition, *with numerous illustrations*, crown 8vo, cloth, 5s.

**Dynamo.**—*Dynamo-Tenders' Hand-Book.* By F. B. BADT. *With 70 illustrations.* Third edition, 18mo, cloth, 4s. 6d.

**Dynamo.**—*Theoretical Elements of Electro-Dynamic Machinery.* By A. E. KENNELLY. *With illustrations*, 8vo, cloth, 4s. 6d.

**Dynamo-Electric Machinery.**—*Dynamo-Electric Machinery*: a Text-Book for Students of Electro-Technology. By SILVANUS P. THOMPSON, B.A., D.Sc. Fifth edition, 8vo, cloth, 24s.

**Earthwork Slips.**—*Earthwork Slips and Subsidence upon Public Works*: Their Causes, Prevention and Reparation. Especially written to assist those engaged in the Construction or Maintenance of Railways, Docks, Canals, Waterworks, River Banks, Reclamation Embankments, Drainage Works, &c., &c. By JOHN NEWMAN, Assoc. Mem. Inst. C.E., Author of 'Notes on Concrete,' &c. Crown 8vo, cloth, 7s. 6d.

**Electric Bells.**—*Electric Bell Construction*: a treatise on the construction of Electric Bells, Indicators, and similar apparatus. By F. C. ALLSOP, Author of 'Practical Electric Bell Fitting.' *With 177 illustrations drawn to scale*, crown 8vo, cloth, 3s. 6d.

**Electric Bells.**—*A Practical Treatise on the fitting up and maintenance of Electric Bells and all the necessary apparatus.* By F. C. ALLSOP, Author of 'Telephones, their Construction and Fitting.' Second edition, revised, *nearly 150 illustrations*, crown 8vo, cloth, 3s. 6d.

**Electric Currents.**—*Polyphase Electric Currents and Alternate Current Motors.* By SILVANUS P. THOMPSON, B.A., D.Sc., M. Inst. E.E., F.R.S. *Numerous cuts and plates*, demy 8vo, cloth, 12s. 6d.

**Electric Lighting.**—*Wrinkles in Electric Lighting.*By VINCENT STEPHEN. *With illustrations.* 18mo, cloth, 2s. 6d.

## CONTENTS:

1. The Electric Current and its production by Chemical means—2. Production of Electric Currents by Mechanical means—3. Dynamo-Electric Machines—4. Electric Lamps—5. Lead—6. Ship Lighting.

**Electric Telegraph.**—*Telegraphic Connections,*embracing recent methods in Quadruplex Telegraphy. By CHARLES THOM and WILLIS H. JONES. *With illustrations.* Oblong 8vo, cloth, 7s. 6d.**Electric Testing.**—*A Guide for the Electric Testing of Telegraph Cables.*

By COL. V. HOSKIER, Royal Danish Engineer. Third edition, crown 8vo, cloth, 4s. 6d.

**Electric Toys.**—*Electric Toys.* Electric Toy-Making, Dynamo Building and Electric Motor Construction for Amateurs. By T. O'CONNOR SLOANE, Ph.D. *With cuts,* crown 8vo, cloth, 4s. 6d.**Electrical Notes.**—*Practical Electrical Notes and**Definitions for the use of Engineering Students and Practical Men.* By W. PERREN MAYCOCK, Assoc. M. Inst. E.E., Instructor in Electrical Engineering at the Pitlake Institute, Croydon, together with the Rules and Regulations to be observed in Electrical Installation Work. Second edition. Royal 32mo, cloth, red edges, 2s.**Electrical Tables.**—*Electrical Tables and Memo-**randa.* By SILVANUS P. THOMPSON, D.Sc., B.A., F.R.S., and EUSTACE THOMAS. In waistcoat-pocket size (2½ in. by 1½ in.), French morocco, gilt edges, *with numerous illustrations,* 1s.**Electrical Testing.**—*A Handbook of Electrical**Testing.* By H. R. KEMPE, M.I.E.E. Fourth edition, revised and enlarged, 8vo, cloth, 18s.**Electrical Testing.**—*A Practical Guide to the**Testing of Insulated Wires and Cables.* By HERBERT LAWS WEBB, Member of the American Institute of Electrical Engineers, and of the Institution of Electrical Engineers, London. Crown 8vo, cloth, 4s. 6d.**Electricity.**—*The Arithmetic of Electricity:* a

Manual of Electrical Calculations by Electrical Methods. By T. O'CONNOR SLOANE. Crown 8vo, cloth, 4s. 6d.

**Electricity.**—*Short Lectures to Electrical Artisans,*

being a Course of Experimental Lectures delivered to a practical audience. By J. A. FLEMING, M.A., D.Sc. (Lond.), Professor of Electrical Technology in University College, London. *With diagrams,* fourth edition, crown 8vo, cloth, 4s.

**Electricity.**—*Electricity, its Theory, Sources, and Applications.*

By JOHN T. SPRAGUE, M. Inst. E.E. Third edition, thoroughly revised and extended, *with numerous illustrations and tables,* crown 8vo, cloth, 15s.

**Electricity.**—*Transformers: their Theory, Construction, and Application Simplified.*

By C. D. HASKINS, Assoc. Mem. American Institute of Electrical Engineers. *Illustrated,* crown 8vo, cloth, 4s. 6d.

**Electricity in the House.**—*Domestic Electricity*

*for Amateurs.* Translated from the French of E. HOSPITALIER, Editor of 'L'Electricien,' by C. J. WHARTON, M. Inst. E.E. *Numerous illustrations.* Demy 8vo, cloth, 6s.

## CONTENTS:

1. Production of the Electric Current—2. Electric Bells—3. Automatic Alarms—4. Domestic Telephones—5. Electric Clocks—6. Electric Lighters—7. Domestic Electric Lighting—8. Domestic Application of the Electric Light—9. Electric Motors—10. Electrical Locomotion—11. Electrotyping, Plating, and Gilding—12. Electric Recreations—13. Various applications—Workshop of the Electrician.

**Electro-Magnet.**—*The Electro-Magnet and Electro-magnetic Mechanism.*

By SILVANUS P. THOMPSON, D.Sc., F.R.S. *With 213 illustrations.* Second edition, 8vo, cloth, 15s.

**Electro-Motors.**—*Notes on design of Small Dynamo.*

By GEO. HALLIDAY, Whitworth Scholar, Professor of Engineering at the Hartley Institute, Southampton. *Plates,* 8vo, cloth, 2s. 6d.

**Electro-Motors.**—*The practical management of*

*Dynamos and Motors.* By FRANCIS B. CROCKER, Professor of Electrical Engineering, Columbia College, New York, and SCHUYLER S. WHEELER, D.Sc. *Cuts,* crown 8vo, cloth, 4s. 6d.

**Engineering Drawing.**—*Practical Geometry,*

*Perspective and Engineering Drawing;* a Course of Descriptive Geometry adapted to the Requirements of the Engineering Draughtsman, including the determination of cast shadows and Isometric Projection, each chapter being followed by numerous examples; to which are added rules for Shading, Shade-lining, etc., together with practical instructions as to the Lining, Colouring, Printing, and general treatment of Engineering Drawings, with a chapter on drawing Instruments. By GEORGE S. CLARKE, Capt. R.E. Second edition, *with 21 plates.* 2 vols., cloth, 10s. 6d.

**Furnaces.**—*Practical Hints on the Working and Construction of Regenerator Furnaces*, being an Explanatory Treatise on the System of Gaseous Firing applicable to Retort Settings in Gas Works. By MAURICE GRAHAM, Assoc. Mem. Inst. C.E. *Cuts*, 8vo, cloth, 3s.

**Gas Analysis.**—*The Gas Engineers' Laboratory Handbook*. By JOHN HORNBY, F.I.C., Honours Medallist in Gas Manipulation, City and Guilds of London Institute. *Numerous illustrations*, crown 8vo, cloth, 6s.

## CONTENTS:

The Balance—Weights and Weighing—Sampling—Mechanical Division—Drying and Desiccation—Solution and Evaporation—Precipitation—Filtration and Treatment of Precipitates—Simple Gravimetric Estimations—Volumetric Analyses—Special Analyses required by Gas Works—Technical Gas Analysis—Gas Referees' Instructions, etc. etc.

**Gas Engines.**—*Gas and Petroleum Engines: a Practical Treatise on the Internal Combustion Engine*. By WM. ROBINSON, M.E., Senior Demonstrator and Lecturer on Applied Mechanics, Physics, &c., City and Guilds of London College, Finsbury, Assoc. Mem. Inst. C.E., &c. *Numerous illustrations*. 8vo, cloth.

**Gas Engineering.**—*Manual for Gas Engineering Students*. By D. LEE. 18mo, cloth, 1s.

**Gas Works.**—*Gas Works: their Arrangement, Construction, Plant, and Machinery*. By F. COLYER, M. Inst. C.E. *With 31 folding plates*, 8vo, cloth, 12s. 6d.

**Gold Mining.**—*Practical Gold-Mining: a Comprehensive Treatise on the Origin and Occurrence of Gold-bearing Gravels, Rocks and Ores, and the Methods by which the Gold is extracted*. By C. G. WARNFORD LOCK, co-Author of 'Gold: its Occurrence and Extraction.' *With 8 plates and 275 engravings in the text*, 788 pp., royal 8vo, cloth, 2l. 2s.

**Graphic Statics.**—*The Elements of Graphic Statics*. By Professor KARL VON OTT, translated from the German by G. S. CLARKE, Capt. R.E., Instructor in Mechanical Drawing, Royal Indian Engineering College. *With 93 illustrations*, crown 8vo, cloth, 5s.

**Graphic Statics.**—*The Principles of Graphic Statics*. By GEORGE SYDENHAM CLARKE, Capt. Royal Engineers. *With 112 illustrations*. Second edition, 4to, cloth, 12s. 6d.

**Graphic Statics.**—*Mechanical Graphics*. A Second Course of Mechanical Drawing. With Preface by Prof. PERRY, B.Sc., F.R.S. Arranged for use in Technical and Science and Art Institutes, Schools and Colleges, by GEORGE HALLIDAY, Whitworth Scholar. *With illustrations*, 8vo, cloth, 6s.

**Graphic Statics.**—*A New Method of Graphic*

*Statics*, applied in the construction of Wrought-Iron Girders, practically illustrated by a series of Working Drawings of modern type. By EDMUND OLANDER, of the Great Western Railway, Assoc. Mem. Inst. C.E. Small folio, cloth, 10s. 6d.

**Heat Engine.**—*Theory and Construction of a*

*Natural Heat Motor*. Translated from the German of RUDOLF DIESEL by BRYAN DONKIN, Mem. Inst. C.E. *Numerous cuts and plates*, 8vo, cloth, 6s.

**Hot Water.**—*Hot Water Supply: a Practical*

Treatise upon the Fitting of Circulating Apparatus in connection with Kitchen Range and other Boilers, to supply Hot Water for Domestic and General Purposes. With a Chapter upon Estimating. By F. DYE. *With illustrations*, crown 8vo, cloth, 3s.

**Hot Water.**—*Hot Water Apparatus: an Ele-*

mentary Guide for the Fitting and Fixing of Boilers and Apparatus for the Circulation of Hot Water for Heating and for Domestic Supply, and containing a Chapter upon Boilers and Fittings for Steam Cooking. By F. DYE. *32 illustrations*, fcap. 8vo, cloth, 1s. 6d.

**Household Manual.**—*Spons' Household Manual:*

a Treasury of Domestic Receipts and Guide for Home Management. Demy 8vo, cloth, containing 975 pages and 250 illustrations, price 7s. 6d.

## PRINCIPAL CONTENTS:

Hints for selecting a good House—Sanitation—Water Supply—Ventilation and Warming—Lighting—Furniture and Decoration—Thieves and Fire—The Larder—Curing Foods for lengthened Preservation—The Dairy—The Cellar—The Pantry—The Kitchen—Receipts for Dishes—The Housewife's Room—Housekeeping, Marketing—The Dining-Room—The Drawing-Room—The Bedroom—The Nursery—The Sick-Room—The Bath-Room—The Laundry—The School-Room—The Playground—The Work-Room—The Library—The Garden—The Farmyard—Small Motors—Household Law.

**House Hunting.**—*Practical Hints on Taking a*

*House*. By H. PERCY BOULNOIS, Mem. Inst. C.E., City Engineer, Liverpool, Author of 'The Municipal and Sanitary Engineer's Handbook,' 'Dirty Dustbins and Sloppy Streets,' &c. 18mo, cloth, 1s. 6d.

**Hydraulics.**—*Simple Hydraulic Formulae.* By

T. W. STONE, C.E., late Resident District Engineer, Victoria Water Supply. Crown 8vo, cloth, 4s.

**Hydraulic Machinery.**—*Hydraulic Steam and*

*Hand-Power Lifting and Pressing Machinery*. By FREDERICK COLVER, M. Inst. C.E., M. Inst. M.E. Second edition, revised and enlarged. *With 88 plates*, 8vo, cloth, 28s.

**Hydraulic Motors.—*Water or Hydraulic Motors.***By PHILIP R. BJÖRLING. *With 206 illustrations, crown 8vo, cloth, 9s.*

## CONTENTS :

1. Introduction—2. Hydraulics relating to Water Motors—3. Water-wheels—4. Breast Water-wheels—5. Overshot and High-breast Water-wheels—6. Pelton Water-wheels—7. General Remarks on Water-wheels—8. Turbines—9. Outward-flow Turbines—10. Inward-flow Turbines—11. Mixed-flow Turbines—12. Parallel-flow Turbines—13. Circumferential-flow Turbines—14. Regulation of Turbines—15. Details of Turbines—16. Water-pressure or Hydraulic Engines—17. Reciprocating Water-pressure Engines—18. Rotative Water-pressure Engines—19. Oscillating Water-pressure Engines—20. Rotary Water-pressure Engines—21. General Remarks and Rules for Water-pressure Engines—22. Hydraulic Rams—23. Hydraulic Rams without Air Vessel in Direct Communication with the Drive Pipe—24. Hydraulic Rams with Air Vessel in Direct Communication with the Drive Pipe—25. Hydraulic Pumping Rams—26. Hydraulic Ram Engines—27. Details of Hydraulic Rams—28. Rules, Formulas, and Tables for Hydraulic Rams—29. Measuring Water in a Stream and over a Weir—Index.

**Hydropathic Establishments.—*The Hydropathic Establishment and its Baths.***By R. O. ALLSOP, Architect. Author of 'The Turkish Bath.' *Illustrated with plates and sections, 8vo, cloth, 5s.*

## CONTENTS :

General Considerations—Requirements of the Hydropathic Establishment—Some existing Institutions—Baths and Treatments and the arrangement of the Bath-House—Vapour Baths and the Russian Bath—The Douche Room and its appliances—Massage and Electrical Treatment—Pulverisation and the Mont Dore Cure—Inhalation and the Pine Cure—The Sun Bath.

**Ice Making.—*Theoretical and Practical Ammonia***

*Refrigeration*, a work of Reference for Engineers and others employed in the management of Ice and Refrigeration Machinery. By ILTYD L. REDWOOD, Assoc. Mem. Am. Soc. of M.E., Mem. Soc. Chemical Industry. *With 25 plates. Square 16mo, cloth, 4s. 6d.*

**Indicator.—*Twenty Years with the Indicator.***By THOMAS PRAY, Jun., C.E., M.E., Member of the American Society of Civil Engineers. *With illustrations, royal 8vo, cloth, 10s. 6d.***Indicator.—*A Treatise on the Richards Steam-***

*Engine Indicator and the Development and Application of Force in the Steam-Engine.* By CHARLES T. PORTER. *With illustrations.* Fourth edition, revised and enlarged, 8vo, cloth, 9s.

**Induction Coils.—*Induction Coils and Coil***

*Making*: a Treatise on the Construction and Working of Shock, Medical and Spark Coils. By F. C. ALLSOP. *With 118 illustrations, crown 8vo, cloth, 3s. 6d.*

**Iron.—*The Mechanical and other Properties of Iron***

*and Steel in connection with their Chemical Composition.* By A. VOSMAER, Engineer. Crown 8vo, cloth, 6s.

## CONTENTS :

The metallurgical behaviour of Carbon with Iron and Steel, also Manganese—Silicon—Phosphorus—Sulphur—Copper—Chromium—Titanium—Tungsten—Aluminium—Nickel—Cobalt—Arsenic—Analyses of Iron and Steel, &c.

**Iron Manufacture.**—*Roll-Turning for Sections in Steel and Iron*, working drawings for Rails, Sleepers, Girders, Bolts, Ties, Angles, &c., also Blooming and Cogging for Plates and Billets. By ADAM SPENCER. Second edition, with 78 large plates. Illustrations of nearly every class of work in this Industry. 4to, cloth, 1*l.* 10*s.*

**Locomotive.**—*The Construction of the Modern Locomotive*. By GEORGE HUGHES, Assistant in the Chief Mechanical Engineer's Department, Lancashire and Yorkshire Railway. Numerous engravings, 8vo, cloth, 9*s.*

## CONTENTS:

The Boiler—The Foundry—the Use of Steel Castings—Brass Foundry—The Forge-Smithy, including Springs—Coppersmiths' Work—The Machine Shop—Erecting.

**Lime and Cement.**—*A Manual of Lime and Cement*, their treatment and use in construction. By A. H. HEALY. Crown 8vo, cloth, 6*s.*

**Liquid Fuel.**—*Liquid Fuel for Mechanical and Industrial Purposes*. Compiled by E. A. BRAYLEY HODGETTS. With wood engravings. 8vo, cloth, 5*s.*

**Machinery Repairs.**—*The Repair and Maintenance of Machinery*; a Handbook of Practical Notes and Memoranda for Engineers and Machinery Users. By T. W. BARBER, C.E., M.E., Author of 'The Engineers' Sketch Book.' With about 400 illustrations, 8vo, cloth, 10*s.* 6*d.*

## CONTENTS:

Steam Boilers—Prime Movers—Wind Motors and Air Engines—Water Motors—Transmission of Power—Hoisting Machinery—Transport—Machine and Hand Tools—Wood Machinery—Pipe Work—Presses—Printing—Repairing Shops and Tools—Lambdas

**Magneto Hand Telephone.**—*The Magneto Hand Telephone*. Its construction, fitting-up, and adaptability to everyday use. By NORMAN HUGHES. Cuts, 12mo, cloth, 3*s.* 6*d.*

**Mechanical Engineering.**—*Handbook for Mechanical Engineers*. By HENRY ADAMS, Professor of Engineering at the City of London College, Mem. Inst. C.E., Mem. Inst. M.E., &c. Second edition, revised and enlarged. Crown 8vo, cloth, 6*s.*

## CONTENTS:

Fundamental Principles of Mechanics—Varieties and Properties of Materials—Strength of Materials and Structures—Pattern Making—Moulding and Founding—Forging, Welding and Riveting—Workshop Tools and General Machinery—Transmission of Power, Friction and Lubrication—Thermodynamics and Steam—Steam Boilers—The Steam Engine—Hydraulic Machinery—Electrical Engineering—Sundry Notes and Tables.

**Mechanical Engineering.**—*The Mechanician :*

a Treatise on the Construction and Manipulation of Tools, for the use and instruction of Young Engineers and Scientific Amateurs, comprising the Arts of Blacksmithing and Forging ; the Construction and Manufacture of Hand Tools, and the various Methods of Using and Grinding them ; description of Hand and Machine Processes ; Turning and Screw Cutting. By CAMERON KNIGHT, Engineer. *Containing 1147 illustrations*, and 397 pages of letter-press. Fourth edition, 4to, cloth, 18s.

**Mechanical Movements.**—*The Engineers' Sketch-*

*Book of Mechanical Movements, Devices, Appliances, Contrivances, Details employed in the Design and Construction of Machinery for every purpose.* Collected from numerous Sources and from Actual Work. Classified and Arranged for Reference. *Nearly 2000 Illustrations.* By T. W. BARBER, Engineer. Second edition, 8vo, cloth, 7s. 6d.

**Metal Plate Work.**—*Metal Plate Work: its*

*Patterns and their Geometry.* Also Notes on Metals and Rules in Mensuration for the use of Tin, Iron, and Zinc Plate-workers, Coppersmiths, Boiler-makers and Plumbers. By C. T. MILLIS, M.I.M.E. Second edition, considerably enlarged. *With numerous illustrations.* Crown 8vo, cloth, 9s.

**Metrical Tables.**—*Metrical Tables.* By Sir G. L.

MOLESWORTH, M.I.C.E. 32mo, cloth, 1s. 6d.

**Mill-Gearing.**—*A Practical Treatise on Mill-Gear-*

*ing, Wheels, Shafts, Riggers, etc. ;* for the use of Engineers. By THOMAS BOX. Third edition, *with 11 plates.* Crown 8vo, cloth, 7s. 6d.

**Mill - Gearing.**—*The Practical Millwright and*

*Engineer's Ready Reckoner ;* or Tables for finding the diameter and power of cog-wheels, diameter, weight, and power of shafts, diameter and strength of bolts, etc. By THOMAS DIXON. Fourth edition, 12mo, cloth, 3s.

**Miners' Pocket-Book.**—*Miners' Pocket-Book ; a*

Reference Book for Miners, Mine Surveyors, Geologists, Mineralogists, Millmen, Assayers, Metallurgists, and Metal Merchants all over the world. By C. G. WARNFORD LOCK, author of 'Practical Gold Mining,' 'Mining and Ore-Dressing Machinery,' &c. Second edition, fcap. 8vo, roan, gilt edges, 12s. 6d.

## CONTENTS :

Motive Power—Dams and Reservoirs—Transmitting Power—Weights and Measures—Prospecting—Boring—Drilling—Blasting—Explosives—Shaft Sinking—Pumping—Ventilating—Lighting—Coal Cutting—Hauling and Hoisting—Water Softening—Stamp Batteries—Crushing Rolls—Jordan's Centrifugal Process—River Mining—Ore Dressing—Gold, Silver, Copper Smelting—Treatment of Ores—Coal Cleaning—Mine Surveying—British Rocks—Geological Maps—Mineral Veins—Mining Methods—Coal Seams—Minerals—Precious Stones—Metals and Metallic Ores—Metalliferous Minerals—Assaying—Glossary—List of Useful Books—Index, &c., &c., &c.



**Mining and Ore-Dressing Machinery.**—By

C. G. WARNFORD LOCK, Author of 'Practical Gold Mining.' *Numerous illustrations, super-royal 4to, cloth, 25s.*

**Mining.**—*Economic Mining; a Practical Hand-*

book for the Miner, the Metallurgist, and the Merchant. By C. G. WARNFORD LOCK, Mem. Inst. of Mining and Metallurgy, Author of 'Practical Gold Mining.' *With illustrations, 8vo, cloth, 21s.*

**Municipal Engineering.**—*The Municipal and*

*Sanitary Engineer's Handbook.* By H. PERCY BOULNOIS, Mem. Inst. C.E., Borough Engineer, Portsmouth. *With numerous illustrations. Second edition, demy 8vo, cloth, 15s.*

## CONTENTS:

The Appointment and Duties of the Town Surveyor—Traffic—Macadamised Roadways—Steam Rolling—Road Metal and Breaking—Pitched Pavements—Asphalte—Wood Pavements—Footpaths—Kerbs and Gutters—Street Naming and Numbering—Street Lighting—Sewage—Ventilation of Sewers—Disposal of Sewage—House Drainage—Disinfection—Gas and Water Companies, etc.—Breaking up Streets—Improvement of Private Streets—Borrowing Powers—Artizans' and Labourers' Dwellings—Public Conveniences—Scavenging, including Street Cleansing—Watering and the Removing of Snow—Planting Street Trees—Deposit of Plans—Dangerous Buildings—Hoardings—Obstructions—Improving Street Lines—Cellar Openings—Public Pleasure Grounds—Cemeteries—Mortuaries—Cattle and Ordinary Markets—Public Slaughter-houses, etc.—Giving numerous Forms of Notices, Specifications, and General Information upon these and other subjects of great importance to Municipal Engineers and others engaged in Sanitary Work.

**Paints.**—*Pigments, Paint and Painting.* A

Practical Book for Practical Men. By GEORGE TERRY. *With illustrations, crown 8vo, cloth, 7s. 6d.*

**Paper Manufacture.**—*A Text-Book of Paper-*

*Making.* By C. F. CROSS and E. J. BEVAN. *With engravings, crown 8vo, cloth, 12s. 6d.*

**Perfumery.**—*Perfumes and their Preparation,*

containing complete directions for making Handkerchief Perfume, Smelling Salts, Sachets, Fumigating Pastils, Preparations for the cure of the Skin, the Mouth, the Hair, and other Toilet articles, with a detailed description of aromatic substances, their nature, tests of purity, and wholesale manufacture. By G. W. ASKINSON, Dr. Chem. *With 32 engravings, 8vo, cloth, 12s. 6d.*

**Perspective.**—*Perspective, Explained and Ill-*

*trated.* By G. S. CLARKE, Capt. R.E. *With illustrations, 8vo, cloth, 3s. 6d.*

**Phonograph.**—*The Phonograph, and How to Con-*

*struct it.* With a Chapter on Sound. By W. GILLETT. *With engravings and full working drawings, crown 8vo, cloth, 5s.*

**Popular Engineering.**—*Popular Engineering, being interesting and instructive examples in Civil, Mechanical, Electrical, Chemical, Mining, Military and Naval Engineering*, graphically and plainly described, and specially written for those about to enter the Engineering Profession and the Scientific Amateur, with chapters on Perpetual Motion and Engineering Schools and Colleges. By F. DYE. With 700 illustrations, crown 4to, cloth, 7s. 6d.

**Plumbing.**—*Plumbing, Drainage, Water Supply and Hot Water Fitting.* By JOHN SMEATON, C.E., M.S.A., R.P., Examiner to the Worshipful Plumbers' Company. Numerous engravings, 8vo, cloth, 7s. 6d.

**Pumping Engines.**—*Practical Handbook on Direct-acting Pumping Engine and Steam Pump Construction.* By PHILIP R. BJÖRLING. With 20 plates, crown 8vo, cloth, 5s.

**Pumps.**—*A Practical Handbook on Pump Construction.* By PHILIP R. BJÖRLING. Plates, crown 8vo, cloth, 5s.

## CONTENTS :

Principle of the action of a Pump—Classification of Pumps—Description of various classes of Pumps—Remarks on designing Pumps—Materials Pumps should be made of for different kinds of Liquids—Description of various classes of Pump-valves—Materials Pump-valves should be made of for different kinds of Liquids—Various Classes of Pump-buckets—On designing Pump-buckets—Various Classes of Pump-pistons—Cup-leathers—Air-vessels—Rules and Formulas, &c., &c.

**Pumps.**—*Pump Details. With 278 illustrations.*

By PHILIP R. BJÖRLING, author of a Practical Handbook on Pump Construction. Crown 8vo, cloth, 7s. 6d.

## CONTENTS :

Windbores—Foot-valves and Strainers—Clack-pieces, Bucket-door-pieces, and H-pieces Working-barrels and Plunger-cases—Plungers or Rams—Piston and Plunger, Bucket and Plunger, Buckets and Valves—Pump-rods and Spears, Spear-rod Guides, &c.—Valve-swords, Spindles, and Draw-hooks—Set-offs or Off-sets—Pipes, Pipe-joints, and Pipe-stays—Pump-slings—Guide-rods and Guides, Kites, Yokes, and Connecting-rods—L Bobs, T Bobs, Angle or V Bobs, and Balance-beams, Rock-arms, and Fend-off Beams, Cisterns, and Tanks—Minor Details.

**Pumps.**—*Pumps and Pumping Machinery.* By

F. COLYER, Mem. Inst. C.E., Mem. Inst. M.E. Part I., second edition, revised and enlarged, with 50 plates, 8vo, cloth, 1l. 8s.

## CONTENTS :

Three-throw Lift and Well Pumps—Tonkin's Patent "Cornish" Steam Pump—Thorne-will and Warham's Steam Pump—Water Valves—Water Meters—Centrifugal Pumping Machinery—Airy and Anderson's Spiral Pumps—Blowing Engines—Air Compressors—Horizontal High-pressure Engines—Horizontal Compound Engines—Reidler Engine—Vertical Compound Pumping Engines—Compound Beam Pumping Engines—Shonheyder's Patent Regulator—Cornish Beam Engines—Worthington High-duty Pumping Engine—Davy's Patent Differential Pumping Engine—Tonkin's Patent Pumping Engine—Lancashire Boiler—Babcock and Wilcox Water-tube Boilers.

**Pumps.**—*Pumps, Historically, Theoretically, and Practically Considered.* By P. R. BJÖRLING. *With 156 illustrations.* Crown 8vo, cloth, 7s. 6d.

**Quantities.**—*A Complete Set of Contract Documents for a Country Lodge*, comprising Drawings, Specifications, Dimensions (for quantities), Abstracts, Bill of Quantities, Form of Tender and Contract, with Notes by J. LEANING, printed in facsimile of the original documents, on single sheets fcap., in linen case, 5s.

**Quantity Surveying.**—*Quantity Surveying.* By J. LEANING. *With 42 illustrations.* Second edition, revised, crown 8vo, cloth, 9s.

## CONTENTS :

A complete Explanation of the London Practice.  
 General Instructions.  
 Order of Taking Off.  
 Modes of Measurement of the various Trades.  
 Use and Waste.  
 Ventilation and Warming.  
 Credits, with various Examples of Treatment.  
 Abbreviations.  
 Squaring the Dimensions.  
 Abstracting, with Examples in illustration of each Trade.  
 Billing.  
 Examples of Preambles to each Trade.  
 Form for a Bill of Quantities.  
 Do. Bill of Credits.  
 Do. Bill for Alternative Estimate.  
 Restorations and Repairs, and Form of Bill.  
 Variations before Acceptance of Tender.  
 Errors in a Builder's Estimate.

Schedule of Prices.  
 Form of Schedule of Prices.  
 Analysis of Schedule of Prices.  
 Adjustment of Accounts.  
 Form of a Bill of Variations.  
 Remarks on Specifications.  
 Prices and Valuation of Work, with Examples and Remarks upon each Trade.  
 The Law as it affects Quantity Surveyors with Law Reports.  
 Taking Off after the Old Method.  
 Northern Practice.  
 The General Statement of the Method recommended by the Manchester Society of Architects for taking Quantities.  
 Examples of Collections.  
 Examples of "Taking Off" in each Trade.  
 Remarks on the Past and Present Methods of Estimating.

**Railway Curves.**—*Tables for Setting out Curves for Railways, Canals, Roads, etc.*, varying from a radius of five chains to three miles. By A. KENNEDY and R. W. HACKWOOD. *Illustrated.* 32mo, cloth, 2s. 6d.

**Roads.**—*The Maintenance of Macadamised Roads.* By T. CODRINGTON, M.I.C.E., F.G.S., General Superintendent of County Roads for South Wales. Second edition, 8vo, cloth, 7s. 6d.

**Scamping Tricks.**—*Scamping Tricks and Odd Knowledge occasionally practised upon Public Works*, chronicled from the confessions of some old Practitioners. By JOHN NEWMAN, Assoc. M. Inst. C.E., author of 'Earthwork Slips and Subsidences upon Public Works,' 'Notes on Concrete,' &c. Crown 8vo, cloth, 2s. 6d.

**Screw Cutting.**—*Turners' Handbook on Screw Cutting, Coning, etc., etc.*, with Tables, Examples, Gauges, and Formulæ. By WALTER PRICE. Fcap. 8vo, cloth, 1s.

**Screw Cutting.**—*Screw Cutting Tables for Engineers and Machinists*, giving the values of the different trains of Wheels required to produce Screws of any pitch, calculated by Lord LINDSAY. Oblong, cloth, 2s.

**Screw Cutting.**—*Screw Cutting Tables*, for the use of Mechanical Engineers, showing the proper arrangement of Wheels for cutting the Threads of Screws of any required pitch, with a Table for making the Universal Gas-pipe Threads and Taps. By W. A. MARTIN, Engineer. Second edition, oblong, cloth, 1s.

**Slide Valve.**—*A Treatise on a Practical Method of Designing Slide-Valve Gears by Simple Geometrical Construction*, based upon the principles enunciated in Euclid's Elements, and comprising the various forms of Plain Slide-Valve and Expansion Gearing; together with Stephenson's, Gooch's, and Allan's Link-Motions, as applied either to reversing or to variable expansion combinations. By EDWARD J. COWLING WELCH, Mem. Inst. M.E. Crown 8vo, cloth, 6s.

**Soap.**—*A Treatise on the Manufacture of Soap and Candles, Lubricants and Glycerine*. By W. LANT CARPENTER, B.A., B.Sc. With illustrations, new edition, revised, crown 8vo, 12s. 6d.

**Stair Building.**—*Practical Stair Building and Handrailing by the Square Section and Falling Line System*. By W. H. WOOD. Folding plates, post 4to, cloth, 10s. 6d.

**Steam Boilers.**—*Steam Boilers, their Management and Working on land and sea*. By JAMES PEATTIE. With illustrations, crown 8vo, cloth, 5s.

**Steam Engine.**—*A Practical Treatise on the Steam Engine*, containing Plans and Arrangements of Details for Fixed Steam Engines, with Essays on the Principles involved in Design and Construction. By ARTHUR RIGG, Engineer, Member of the Society of Engineers and of the Royal Institution of Great Britain. Demy 4to, copiously illustrated with woodcuts and 103 plates, in one Volume. Second edition, cloth, 25s.

This work is not, in any sense, an elementary treatise, or history of the steam engine, but is intended to describe examples of Fixed Steam Engines without entering into the wide domain of locomotive or marine practice. To this end illustrations will be given of the most recent arrangements of Horizontal, Vertical, Beam, Pumping, Winding, Portable, Semi-portable, Corliss, Allen, Compound, and other similar Engines, by the most eminent Firms in Great Britain and America. The laws relating to the action and precautions to be observed in the construction of the various details, such as Cylinders, Pistons, Piston-rods, Connecting-rods, Cross-heads, Motion-blocks, Eccentrics, Simple, Expansion, Balanced, and Equilibrium Slide-valves, and Valve-gearing will be minutely dealt with. In this connection will be found articles upon the Velocity of Reciprocating Parts and the Mode of Applying the Indicator, Heat and Expansion of Steam Governors, and the like. It is the writer's desire to draw illustrations from every possible source, and give only those rules that present practice deems correct.

**Steam Engine.**—*The Steam Engine considered as a Thermodynamic Machine*, a treatise on the Thermodynamic efficiency of Steam Engines, illustrated by Tables, Diagrams, and Examples from Practice. By JAS. H. COTTERILL, M.A., F.R.S., Professor of Applied Mechanics in the Royal Naval College. Third edition, revised and enlarged, 8vo, cloth, 15s.

**Steam Engine.**—*Steam Engine Management*; a Treatise on the Working and Management of Steam Boilers. By F. COLYER, M. Inst. C.E., Mem. Inst. M.E. New edition, 18mo, cloth, 3s. 6d.

**Steam Engine.**—*A Treatise on Modern Steam Engines and Boilers*, including Land, Locomotive and Marine Engines and Boilers, for the use of Students. By FREDERICK COLYER, M. Inst. C.E., Mem. Inst. M.E. With 36 plates. 4to, cloth, 12s. 6d.

## CONTENTS :

1. Introduction—2. Original Engines—3. Boilers—4. High-Pressure Beam Engines—5. Cornish Beam Engines—6. Horizontal Engines—7. Oscillating Engines—8. Vertical High-Pressure Engines—9. Special Engines—10. Portable Engines—11. Locomotive Engines—12. Marine Engines.

**Sugar.**—*A Handbook for Planters and Refiners*; being a comprehensive Treatise on the Culture of Sugar-yielding Plants, and on the Manufacture, Refining, and Analysis of Cane, Palm, Maple, Melon, Beet, Sorghum, Milk, and Starch Sugars; with copious Statistics of their Production and Commerce, and a chapter on the Distillation of Rum. By C. G. WARNFORD LOCK, F.L.S., &c.; B. E. R. NEWLANDS, F.C.S., F.I.C., Mem. Council Soc. Chemical Industry; and J. A. R. NEWLANDS, F.C.S., F.I.C. Upwards of 200 illustrations and many plates, 8vo, cloth, 1l. 10s.

**Surveying.**—*A Practical Treatise on the Science of Land and Engineering Surveying, Levelling, Estimating Quantities, &c.*, with a general description of the several Instruments required for Surveying, Levelling, Plotting, &c. By H. S. MERRETT. Fourth edition, revised by G. W. USILL, Assoc. Mem. Inst. C.E. 41 plates, with illustrations and tables, royal 8vo, cloth, 12s. 6d.

**Surveying and Levelling.**—*Surveying and Levelling Instruments theoretically and practically described*, for construction, qualities, selection, preservation, adjustments, and uses, with other apparatus and appliances used by Civil Engineers and Surveyors. By W. F. STANLEY. Second edition. 350 cuts, crown 8vo, cloth, 7s. 6d.

**Tables of Logarithms.**—*A B C Five-Figure*

*Logarithms for general use.* By C. J. WOODWARD, B.Sc. Containing Mantissæ of numbers to 10,000. Log. Sines, Tangents, Cotangents, and Cosines to 10" of Arc. Together with full explanations and simple exercises showing use of the tables. 4s.

**Tables of Squares.**—*Barlow's Tables of Squares,*

*Cubes, Square Roots, Cube Roots, Reciprocals of all Integer Numbers up to 10,000.* Post 8vo, cloth, 6s.

**Telephones.**—*Telephones, their Construction and*

*Fitting.* By F. C. ALLSOP. Second edition, revised and enlarged. With 210 illustrations. Crown 8vo, cloth, 5s.

**Tobacco Cultivation.**—*Tobacco Growing, Curing,*

*and Manufacturing;* a Handbook for Planters in all parts of the world. Edited by C. G. WARNFORD LOCK, F.L.S. With illustrations. Crown 8vo, cloth, 7s. 6d.

**Tropical Agriculture.**—*Tropical Agriculture: a*

Treatise on the Culture, Preparation, Commerce and Consumption of the principal Products of the Vegetable Kingdom. By P. L. SIMMONDS, F.L.S., F.R.C.I. New edition, revised and enlarged, 8vo, cloth, 21s.

**Turning.**—*The Practice of Hand Turning in Wood,*

*Ivory, Shell, etc.,* with Instructions for Turning such Work in Metal as may be required in the Practice of Turning in Wood, Ivory, etc.; also an Appendix on Ornamental Turning. (A book for beginners.) By FRANCIS CAMPIN. Third edition, with wood engravings, crown 8vo, cloth, 3s. 6d.

**Valve Gears.**—*Treatise on Valve-Gears,* with

special consideration of the Link-Motions of Locomotive Engines. By Dr. GUSTAV ZEUNER, Professor of Applied Mechanics at the Confederated Polytechnikum of Zurich. Translated from the Fourth German Edition, by Professor J. F. KLEIN, Lehigh University, Bethlehem, Pa. Illustrated, 8vo, cloth, 12s. 6d.

**Varnish.**—*The practical Polish and Varnish-Maker;*

a Treatise containing 750 practical Receipts and Formulæ for the Manufacture of Polishes, Lacquers, Varnishes, and Japans of all kinds, for workers in Wood and Metal, and directions for using same. By H. C. STANDAGE (Practical Chemist), author of 'The Artist's Manual of Pigments.' Crown 8vo, cloth, 6s.

**Ventilation.**—*Health and Comfort in House Building*; or, Ventilation with Warm Air by Self-acting Suction Power. With Review of the Mode of Calculating the Draught in Hot-air Flues, and with some Actual Experiments by J. DRYSDALE, M.D., and J. W. HAYWARD, M.D. *With plates and woodcuts.* Third edition, with some New Sections, and the whole carefully revised, 8vo, cloth, 7s. 6d.

**Warming and Ventilating.**—*A Practical Treatise upon Warming Buildings by Hot Water*, and upon Heat and Heating Appliances in general; with an inquiry respecting Ventilation, the cause and action of Draughts in Chimneys and Flues, and the laws relating to Combustion. By CHARLES HOOD, F.R.S., F.R.A.S., &c. Re-written by FREDERICK DYE. 8vo, cloth, 15s.

**Watchwork.**—*Treatise on Watchwork, Past and Present.* By the Rev. H. L. NELTHROPP, M.A., F.S.A. *With 32 illustrations,* crown 8vo, cloth, 6s. 6d.

CONTENTS:

Definitions of Words and Terms used in Watchwork—Tools—Time—Historical Summary—On Calculations of the Numbers for Wheels and Pinions; their Proportional Sins, Trains, etc.—Of Dial Wheels, or Motion Work—Length of Time of Going without Winding up—The Verge—The Horizontal—The Duplex—The Lever—The Chronometer—Repeating Watches—Keyless Watches—The Pendulum, or Spiral Spring—Compensation—Jewelling of Pivot Holes—Clerkenwell—Fallacies of the Trade—Incapacity of Workmen—How to Choose and Use a Watch, etc.

**Waterworks.**—*The Principles of Waterworks Engineering.* By J. H. TUDSBURY TURNER, B.Sc., Hunter Medallist of Glasgow University, M. Inst. C.E., and A. W. BRIGHTMORE, M.Sc., Assoc. M. Inst. C.E. *With illustrations,* medium 8vo, cloth, 25s.

**Well Sinking.**—*Well Sinking.* The modern practice of Sinking and Boring Wells, with geological considerations and examples of Wells. By ERNEST SPON, Assoc. Mem. Inst. C.E. Second edition, revised and enlarged. Crown 8vo, cloth, 10s. 6d.

**Wiring.**—*Incandescent Wiring Hand-Book.* By F. B. BADT, late 1st Lieut. Royal Prussian Artillery. *With 41 illustrations and 5 tables.* 18mo, cloth, 4s. 6d.

**Wood-working Factories.**—*On the Arrangement, Care, and Operation of Wood-working Factories and Machinery,* forming a complete Operator's Handbook. By J. RICHARD, Mechanical Engineer. Second edition, revised, *woodcuts,* crown 8vo, cloth, 5s.

## SPONS' DICTIONARY OF ENGINEERING,

CIVIL, MECHANICAL, MILITARY, &amp; NAVAL,

WITH

Technical Terms in French, German, Italian, and Spanish.

In 97 numbers, Super-royal 8vo, containing 3132 *printed pages* and 7414 *engravings*. Any number can be had separate: Nos. 1 to 95 1s. each, post free; Nos. 96, 97, 2s., post free.

## COMPLETE LIST OF ALL THE SUBJECTS:

	Nos.		Nos.
Abacus .. .. .	1	Barrage .. .. .	8 and 9
Adhesion .. .. .	1	Battery .. .. .	9 and 10
Agricultural Engines ..	1 and 2	Bell and Bell-hanging ..	10
Air-Chamber .. .. .	2	Belts and Belting .. ..	10 and 11
Air-Pump .. .. .	2	Bismuth .. .. .	11
Algebraic Signs .. .. .	2	Blast Furnace .. .. .	11 and 12
Alloy .. .. .	2	Blowing Machine .. .. .	12
Aluminium .. .. .	2	Body Plan .. .. .	12 and 13
Amalgamating Machine ..	2	Boilers .. .. .	13, 14, 15
Ambulance .. .. .	2	Bond .. .. .	15 and 16
Anchors .. .. .	2	Bone Mill .. .. .	16
Anemometer .. .. .	2 and 3	Boot-making Machinery ..	16
Angular Motion .. .. .	3 and 4	Boring and Blasting .. ..	16 to 19
Angle-iron .. .. .	3	Brake .. .. .	19 and 20
Angle of Friction .. .. .	3	Bread Machine .. .. .	20
Animal Charcoal Machine ..	4	Brewing Apparatus .. .. .	20 and 21
Antimony, 4; Anvil .. .. .	4	Brick-making Machines ..	21
Aqueduct, 4; Arch .. .. .	4	Bridges .. .. .	21 to 28
Archimedean Screw .. .. .	4	Buffer .. .. .	28
Arming Press .. .. .	4 and 5	Cables .. .. .	28 and 29
Armour, 5; Arsenic .. .. .	5	Canal, 29; Canal .. .. .	29
Artesian Well .. .. .	5	Candles .. .. .	29 and 30
Artillery, 5 and 6; Assaying ..	6	Cement, 30; Chimney .. .. .	30
Atomic Weights .. .. .	6 and 7	Coal Cutting and Washing Ma-	
Auger, 7; Axles .. .. .	7	chinery .. .. .	31
Balance, 7; Ballast .. .. .	7	Coast Defence .. .. .	31, 32
Bank Note Machinery .. .. .	7	Compasses .. .. .	32
Barn Machinery .. .. .	7 and 8	Construction .. .. .	32 and 33
Barker's Mill .. .. .	8	Cooler, 34; Copper .. .. .	34
Barometer, 8; Barracks .. ..	8	Cork-cutting Machine .. ..	34



	Nos.		Nos.
Corrosion .. ..	.. 34 and 35	Isomorphism, 68; Joints ..	.. 63
Cotton Machinery .. ..	.. .. 35	Keels and Coal Shipping ..	68 and 69
Damming .. ..	.. 35 to 37	Kiln, 69; Knitting Machine ..	.. 69
Details of Engines .. ..	.. 37, 38	Kyanising .. ..	.. 69
Displacement .. ..	.. .. 38	Lamp, Safety .. ..	69, 70
Distilling Apparatus ..	.. 38 and 39	Lead .. ..	.. 70
Diving and Diving Bells ..	.. 39	Lifts, Hoists .. ..	.. 70, 71
Docks .. ..	.. 39 and 40	Lights, Buoys, Beacons ..	71 and 72
Drainage .. ..	.. 40 and 41	Limes, Mortars, and Cements ..	.. 72
Drawbridge .. ..	.. .. 41	Locks and Lock Gates ..	72, 73
Dredging Machine .. ..	.. .. 41	Locomotive .. ..	.. 73
Dynamometer .. ..	.. 41 to 43	Machine Tools .. ..	73, 74
Electro-Metallurgy .. ..	.. 43, 44	Manganese .. ..	.. 74
Engines, Varieties .. ..	.. 44, 45	Marine Engine .. ..	74 and 75
Engines, Agricultural .. ..	.. 1 and 2	Materials of Construction ..	75 and 76
Engines, Marine .. ..	.. 74, 75	Measuring and Folding ..	.. 76
Engines, Screw .. ..	.. 89, 90	Mechanical Movements ..	76, 77
Engines, Stationary .. ..	.. 91, 92	Mercury, 77; Metallurgy ..	.. 77
Escapement .. ..	.. 45, 46	Meter .. ..	77, 78
Fan .. ..	.. .. 46	Metric System .. ..	.. 78
File-cutting Machine .. ..	.. .. 46	Mills .. ..	78, 79
Fire-arms .. ..	.. 46, 47	Molecule, 79; Oblique Arch ..	.. 79
Flax Machinery .. ..	.. 47, 48	Ores, 79, 80; Ovens .. ..	.. 80
Floot Water-wheels .. ..	.. .. 48	Over-shot Water-wheel ..	80, 81
Forging .. ..	.. .. 48	Paper Machinery .. ..	.. 81
Founding and Casting ..	.. 48 to 50	Permanent Way .. ..	81, 82
Friction, 50; Friction, Angle of ..	.. 3	Piles and File-driving ..	82 and 83
Fuel, 50; Furnace .. ..	.. 50, 51	Pipes .. ..	83, 84
Fuze, 51; Gas .. ..	.. .. 51	Planimeter .. ..	.. 84
Gearing .. ..	.. 51, 52	Pumps .. ..	84 and 85
Gearing Belt .. ..	.. 10, 11	Quarrying .. ..	.. 85
Geodesy .. ..	.. 52 and 53	Railway Engineering ..	85 and 86
Glass Machinery .. ..	.. .. 53	Retaining Walls .. ..	.. 86
Gold, 53, 54; Governor ..	.. 54	Rivers, 86, 87; Riveted Joint ..	.. 87
Gravity, 54; Grindstone ..	.. 54	Roads .. ..	87, 88
Gun-carriage, 54; Gun Metal ..	.. 54	Roofs .. ..	88, 89
Gunnery .. ..	.. 54 to 56	Rope-making Machinery ..	.. 89
Gunpowder .. ..	.. .. 56	Scaffolding .. ..	.. 89
Gun Machinery .. ..	.. 56, 57	Screw Engines .. ..	89, 90
Hand Tools .. ..	.. 57, 58	Signals, 90; Silver .. ..	90, 91
Hanger, 58; Harbour .. ..	.. 58	Stationary Engine .. ..	91, 92
Haulage, 58, 59; Hinging ..	.. 59	Stave-making & Cask Machinery ..	92
Hydraulics and Hydraulic Machinery ..	.. 59 to 63	Steel, 92; Sugar Mill ..	92, 93
Ice-making Machine .. ..	.. .. 63	Surveying and Surveying Instruments ..	.. 93, 94
India-rubber .. ..	.. .. 63	Telegraphy .. ..	94, 95
Indicator .. ..	.. 63 and 64	Testing, 95; Turbine .. ..	.. 95
Injector .. ..	.. .. 64	Ventilation .. ..	95, 96, 97
Iron .. ..	.. 64 to 67	Waterworks .. ..	96, 97
Iron Ship Building .. ..	.. .. 67	Wood-working Machinery ..	96, 97
Irrigation .. ..	.. 67 and 68	Zinc .. ..	.. 96, 97

In super-royal 8vo, 1168 pp., with 2400 illustrations, in 3 Divisions, cloth, price 13s. 6d. each; or 1 vol., cloth, 2l.; or half-morocco, 2l. 8s.

# A SUPPLEMENT TO SPONS' DICTIONARY OF ENGINEERING.

EDITED BY ERNEST SPON, MEMB. SOC. ENGINEERS.

Abacus, Counters, Speed Indicators, and Slide Rule.	Coal Mining.	Lighthouses, Buoys, and Beacons.
Agricultural Implements and Machinery.	Coal Cutting Machines.	Machine Tools.
Air Compressors.	Coke Ovens. Copper.	Materials of Construction.
Animal Charcoal Machinery.	Docks. Drainage.	Meters.
Antimony.	Dredging Machinery.	Ores, Machinery and Processes employed to Dress.
Axles and Axle-boxes.	Dynamo - Electric and Magneto-Electric Machines.	Piers.
Barn Machinery.	Dynamometers.	Pile Driving.
Belts and Belting.	Electrical Engineering, Telegraphy, Electric Lighting and its practical details, Telephones	Pneumatic Transmission.
Blasting. Boilers.	Engines, Varieties of.	Pumps.
Brakes.	Explosives. Fans.	Pyrometers.
Brick Machinery.	Founding, Moulding and the practical work of the Foundry.	Road Locomotives.
Bridges.	Gas, Manufacture of.	Rock Drills.
Cages for Mines.	Hammers, Steam and other Power.	Rolling Stock.
Calculus, Differential and Integral.	Heat. Horse Power.	Sanitary Engineering.
Canals.	Hydraulics.	Shafting.
Carpentry.	Hydro-geology.	Steel.
Cast Iron.	Indicators. Iron.	Steam Navvy.
Cement, Concrete, Limes, and Mortar.	Lifts, Hoists, and Elevators.	Stone Machinery.
Chimney Shafts.		Tramways.
Coal Cleansing and Washing.		Well Sinking.

In demy 4to, handsomely bound in cloth, *illustrated with 220 full page plates*,  
Price 15s.

## ARCHITECTURAL EXAMPLES IN BRICK, STONE, WOOD, AND IRON.

A COMPLETE WORK ON THE DETAILS AND ARRANGEMENT  
OF BUILDING CONSTRUCTION AND DESIGN.

BY WILLIAM FULLERTON, ARCHITECT.

Containing 220 Plates, with numerous Drawings selected from the Architecture  
of Former and Present Times.

*The Details and Designs are Drawn to Scale,  $\frac{1}{8}$ " ,  $\frac{1}{4}$ " ,  $\frac{1}{2}$ " , and Full size  
being chiefly used.*

The Plates are arranged in Two Parts. The First Part contains Details of Work in the four principal Building materials, the following being a few of the subjects in this Part:—Various forms of Doors and Windows, Wood and Iron Roofs, Half Timber Work, Porches, Towers, Spires, Belfries, Flying Buttresses, Groining, Carving, Church Fittings, Constructive and Ornamental Iron Work, Classic and Gothic Molds and Ornament, Foliation Natural and Conventional, Stained Glass, Coloured Decoration, a Section to Scale of the Great Pyramid, Grecian and Roman Work, Continental and English Gothic, Pile Foundations, Chimney Shafts according to the regulations of the London County Council, Board Schools. The Second Part consists of Drawings of Plans and Elevations of Buildings, arranged under the following heads:—Workmen's Cottages and Dwellings, Cottage Residences and Dwelling Houses, Shops, Factories, Warehouses, Schools, Churches and Chapels, Public Buildings, Hotels and Taverns, and Buildings of a general character.

All the Plates are accompanied with particulars of the Work, with Explanatory Notes and Dimensions of the various parts.

Architectural Examples—Town Hall—

211.

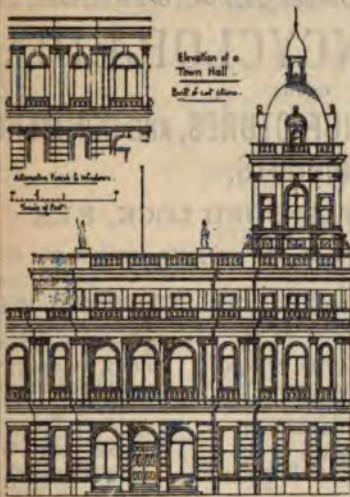

Architectural Examples—Brockwork &c.



Architectural Examples—

21.



Architectural Examples—Windows

72



With nearly 1500 illustrations, in super-royal 8vo, in 5 Divisions, cloth. Divisions 1 to 4, 13s. 6d. each; Division 5, 17s. 6d.; or 2 vols., cloth, £3 10s.

# SPONS' ENCYCLOPÆDIA

OF THE

## INDUSTRIAL ARTS, MANUFACTURES, AND COMMERCIAL PRODUCTS.

EDITED BY C. G. WARNFORD LOCK, F.L.S.

Among the more important of the subjects treated of, are the following:—

- |  |   |  |
|--|---|--|
| Acids, 207 pp. 220 figs.                   | Fur, 5 pp.                                | Photography, 13 pp. 20 figs.                   |
| Alcohol, 23 pp. 16 figs.                   | Gas, Coal, 8 pp.                          | Pigments, 9 pp. 6 figs.                        |
| Alcoholic Liquors, 13 pp.                  | Gems.                                     | Pottery, 46 pp. 57 figs.                       |
| Alkalies, 89 pp. 78 figs.                  | Glass, 45 pp. 77 figs.                    | Printing and Engraving, 20 pp. 8 figs.         |
| Alloys. Alum.                              | Graphite, 7 pp.                           | Rags.  |
| Asphalt. Assaying.                         | Hair, 7 pp.                               | Resinous and Gummy Substances, 75 pp. 16 figs. |
| Beverages, 89 pp. 29 figs.                 | Hair Manufactures.                        | Rope, 16 pp. 17 figs.                          |
| Blacks.                                    | Hats, 26 pp. 26 figs.                     | Salt, 31 pp. 23 figs.                          |
| Bleaching Powder, 15 pp.                   | Honey. Hops.                              | Silk, 8 pp.                                    |
| Bleaching, 51 pp. 48 figs.                 | Horn.                                     | Silk Manufactures, 9 pp. 11 figs.              |
| Candles, 18 pp. 9 figs.                    | Ice, 10 pp. 14 figs.                      | Skins, 5 pp.                                   |
| Carbon Bisulphide.                         | Indiarubber Manufactures, 23 pp. 17 figs. | Small Wares, 4 pp.                             |
| Celluloid, 9 pp.                           | Ink, 17 pp.                               | Soap and Glycerine, 39 pp. 45 figs.            |
| Cements. Clay.                             | Ivory.                                    | Spices, 16 pp.                                 |
| Coal-tar Products, 44 pp. 14 figs.         | Jute Manufactures, 11 pp., 11 figs.       | Sponge, 5 pp.                                  |
| Cocoa, 8 pp.                               | Knitted Fabrics —                         | Starch, 9 pp. 10 figs.                         |
| Coffee, 32 pp. 13 figs.                    | Hosiery, 15 pp. 13 figs.                  | Sugar, 155 pp. 134 figs.                       |
| Cork, 8 pp. 17 figs.                       | Lace, 13 pp. 9 figs.                      | Sulphur.                                       |
| Cotton Manufactures, 62 pp. 57 figs.       | Leather, 28 pp. 31 figs.                  | Tannin, 18 pp.                                 |
| Drugs, 38 pp.                              | Linen Manufactures, 16 pp. 6 figs.        | Tea, 12 pp.                                    |
| Dyeing and Calico Printing, 28 pp. 9 figs. | Manures, 21 pp. 30 figs.                  | Timber, 13 pp.                                 |
| Dyestuffs, 16 pp.                          | Matches, 17 pp. 38 figs.                  | Varnish, 15 pp.                                |
| Electro-Metallurgy, 13 pp.                 | Mordants, 13 pp.                          | Vinegar, 5 pp.                                 |
| Explosives, 22 pp. 33 figs.                | Narcotics, 47 pp.                         | Wax, 5 pp.                                     |
| Feathers.                                  | Nuts, 10 pp.                              | Wool, 2 pp.                                    |
| Fibrous Substances, 92 pp. 79 figs.        | Oils and Fatty Substances, 125 pp.        | Woolen Manufactures, 58 pp. 39 figs.           |
| Floor-cloth, 16 pp. 21 figs.               | Paint.                                    |  |
| Food Preservation, 8 pp.                   | Paper, 26 pp. 23 figs.                    |  |
| Fruit, 8 pp.                               | Paraffin, 8 pp. 6 figs.                   |  |
|  | Pearl and Coral, 8 pp.                    |  |
|  | Perfumes, 10 pp.                          |  |

JUST PUBLISHED, SECOND EDITION.

Crown 8vo, cloth, with illustrations, 5s.

# WORKSHOP RECEIPTS, FIRST SERIES.

## SYNOPSIS OF CONTENTS.

Bookbinding.	Freezing.	Paper.
Bronzes and Bronzing.	Fulminates.	Paper Hanging.
Candles.	Furniture Creams, Oils,	Painting in Oils, in Water
Cement.	Polishes, Lacquers,	Colours, as well as
Cleaning.	and Pastes.	Fresco, House, Trans-
Colourwashing.	Gilding.	parency, Sign, and
Concretes.	Glass Cutting, Cleaning,	Carriage Painting.
Dipping Acids.	Frosting, Drilling,	Photography.
Drawing Office Details.	Darkening, Bending,	Plastering.
Drying Oils.	Staining, and Paint-	Polishes.
Dynamite.	ing.	Pottery—(Clays, Bodies,
Electro - Metallurgy —	Glass Making.	Glazes, Colours, Oils,
(Cleaning, Dipping,	Glues.	Stains, Fluxes, Ena-
Scratch-brushing, Bat-	Gold.	mels, and Lustres).
teries, Baths, and	Graining.	Scouring.
Deposits of every	Gums.	Silvering.
description).	Gun Cotton.	Soap.
Enamels.	Gunpowder.	Solders.
Engraving on Wood,	Horn Working.	Tanning.
Copper, Gold, Silver,	Indiarubber.	Taxidermy.
Steel, and Stone.	Japans, Japanning, and	Tempering Metals.
Etching and Aqua Tint.	kindred processes.	Treating Horn, Mother-
Firework Making —	Lacquers.	o'-pearl, and like sub-
(Rockets, Stars, Rains,	Lathing.	stances.
Gerbes, Jets, Tour-	Lubricants.	Varnishes, Manufacture
billons, Candles, Fires,	Marble Working.	and Use of.
Lances, Lights, Wheels,	Matches.	Veneering.
Fire-balloons, and	Mortars.	Washing.
minor Fireworks).	Nitro-Glycerine.	Waterproofing.
Fluxes.	Oils.	Welding.
Foundry Mixtures.		

Besides Receipts relating to the lesser Technological matters and processes, such as the manufacture and use of Stencil Plates, Blacking, Crayons, Paste, Putty, Wax, Size, Alloys, Catgut, Tunbridge Ware, Picture Frame and Architectural Mouldings, Compos, Cameos, and others too numerous to mention.

Crown 8vo, cloth, 485 pages, with illustrations, 54.

## WORKSHOP RECEIPTS, SECOND SERIES.

### SYNOPSIS OF CONTENTS.

Acidimetry and Alkali- metry.	Disinfectants.	Iodoform.
Albumen.	Dyeing, Staining, and Colouring.	Isinglass.
Alcohol.	Essences.	Ivory substitutes.
Alkaloids.	Extracts.	Leather.
Baking-powders.	Fireproofing.	Luminous bodies.
Bitters.	Gelatine, Glue, and Size.	Magnesia.
Bleaching.	Glycerine.	Matches.
Boiler Incrustations.	Gut.	Paper.
Cements and Lutes.	Hydrogen peroxide.	Parchment.
Cleansing.	Ink.	Perchloric acid.
Confectionery.	Iodine.	Potassium oxalate.
Copying.		Preserving.

**Pigments, Paint, and Painting:** embracing the preparation of *Pigments*, including alumina lakes, blacks (animal, bone, Frankfort, ivory, lamp, sight, soot), blues (antimony, Antwerp, cobalt, cæruleum, Egyptian, manganate, Paris, Péligot, Prussian, smalt, ultramarine), browns (bistre, hinau, sepia, sienna, umber, Vandyke), greens (baryta, Brighton, Brunswick, chrome, cobalt, Douglas, emerald, manganese, mitis, mountain, Prussian, sap, Scheele's, Schweinfurth, titanium, verdigris, zinc), reds (Brazilwood lake, carminated lake, carmine, Cassius purple, cobalt pink, cochineal lake, colcothar, Indian red, madder lake, red chalk, red lead, vermilion), whites (alum, baryta, Chinese, lead sulphate, white lead—by American, Dutch, French, German, Kremnitz, and Pattinson processes, precautions in making, and composition of commercial samples—whiting, Wilkinson's white, zinc white), yellows (chrome, gamboge, Naples, orpiment, realgar, yellow lakes); *Paint* (vehicles, testing oils, driers, grinding, storing, applying, priming, drying, filling, coats, brushes, surface, water-colours, removing smell, discoloration; miscellaneous paints—cement paint for carton-pierre, copper paint, gold paint, iron paint, lime paints, silicated paints, steatite paint, transparent paints, tungsten paints, window paint, zinc paints); *Painting* (general instructions, proportions of ingredients, measuring paint work; carriage painting—priming paint, best putty, finishing colour, cause of cracking, mixing the paints, oils, driers, and colours, varnishing, importance of washing vehicles, re-varnishing, how to dry paint; woodwork painting).

Crown 8vo, cloth, 480 pages, with 183 illustrations, 5s.

# WORKSHOP RECEIPTS,

## THIRD SERIES.

Uniform with the First and Second Series.

### SYNOPSIS OF CONTENTS.

Alloys.	Iridium.	Rubidium.
Aluminium.	Iron and Steel.	Ruthenium.
Antimony.	Lacquers and Lacquering.	Selenium.
Barium.	Lanthanum.	Silver.
Beryllium.	Lead.	Slag.
Bismuth.	Lithium.	Sodium.
Cadmium.	Lubricants.	Strontium.
Cæsium.	Magnesium.	Tantalum.
Calcium.	Manganese.	Terbium.
Cerium.	Mercury.	Thallium.
Chromium.	Mica.	Thorium.
Cobalt.	Molybdenum.	Tin.
Copper.	Nickel.	Titanium.
Didymium.	Niobium.	Tungsten.
Enamels and Glazes.	Osmium.	Uranium.
Erbium.	Palladium.	Vanadium.
Gallium.	Platinum.	Yttrium.
Glass.	Potassium.	Zinc.
Gold.	Rhodium.	Zirconium.
Indium.		

*Electrics.*—Alarms, Bells, Batteries, Carbons, Coils, Dynamos, Microphones, Measuring, Phonographs, Telephones, &c., 130 pp., 112 illustrations.



## WORKSHOP RECEIPTS, FOURTH SERIES,

DEVOTED MAINLY TO HANDICRAFTS & MECHANICAL SUBJECTS.

250 Illustrations, with Complete Index, and a General Index to the  
Four Series, 5s.

- Waterproofing—rubber goods, cuprammonium processes, miscellaneous preparations.
- Packing and Storing articles of delicate odour or colour, of a deliquescent character, liable to ignition, apt to suffer from insects or damp, or easily broken.
- Embalming and Preserving anatomical specimens.
- Leather Polishes.
- Cooling Air and Water, producing low temperatures, making ice, cooling syrups and solutions, and separating salts from liquors by refrigeration.
- Pumps and Siphons, embracing every useful contrivance for raising and supplying water on a moderate scale, and moving corrosive, tenacious, and other liquids.
- Desiccating—air- and water-ovens, and other appliances for drying natural and artificial products.
- Distilling—water, tinctures, extracts, pharmaceutical preparations, essences, perfumes, and alcoholic liquids.
- Emulsifying as required by pharmacists and photographers.
- Evaporating—saline and other solutions, and liquids demanding special precautions.
- Filtering—water, and solutions of various kinds.
- Percolating and Macerating.
- Electrotyping.
- Stereotyping by both plaster and paper processes.
- Bookbinding in all its details.
- Straw Plaiting and the fabrication of baskets, matting, etc.
- Musical Instruments—the preservation, tuning, and repair of pianos, harmoniums, musical boxes, etc.
- Clock and Watch Mending—adapted for intelligent amateurs.
- Photography—recent development in rapid processes, handy apparatus, numerous recipes for sensitizing and developing solutions, and applications to modern illustrative purposes.

Crown 8vo, cloth, with 373 illustrations, price 5s.

## WORKSHOP RECEIPTS, FIFTH SERIES.

Containing many new Articles, as well as additions to Articles included in the previous Series, as follows, viz. :—

- |   |  |
|---|--|
| Anemometers.  | Glass Manipulations for Laboratory Apparatus.  |
| Barometers, How to make.  | Labels. Lacquers.  |
| Boat Building.  | Illuminating Agents.   |
| Camera Lucida, How to use.  | Inks. Writing, Copying, Invisible, Marking, Stamping.  |
| Cements and Lutes.  | Magic Lanterns, their management and preparation of slides.  |
| Cooling.  | Metal Work. Casting Ornamental Metal Work, Copper Welding Enamels for Iron and other Metals, Gold Beating, Smiths' Work. |
| Copying.  | Modelling and Plaster Casting.   |
| Corrosion and Protection of Metal Surfaces.   | Netting.   |
| Dendrometer, How to use.  | Packing and Storing. Acids, &c.  |
| Desiccating.  | Percolation.   |
| Diamond Cutting and Polishing. Electrics. New Chemical Batteries, Bells, Commutators, Galvanometers, Cost of Electric Lighting, Microphones, Simple Motors, Phonogram and Graphophone, Registering Apparatus, Regulators, Electric Welding and Apparatus, Transformers. | Preserving Books.  |
| Evaporating.  | Preserving Food, Plants, &c.   |
| Explosives.   | Pumps and Syphons for various liquids.   |
| Filtering.  | Repairing Books.   |
| Fireproofing, Buildings, Textile Fabrics.   | Rope Tackle.   |
| Fire-extinguishing Compounds and Apparatus.   | Stereotyping.  |
| Glass Manipulating. Drilling, Cutting, Breaking, Etching, Frosting, Powdering, &c.  | Taps, Various.   |
|   | Tobacco Pipe Manufacture.  |
|   | Tying and Splicing Ropes.  |
|   | Velocipedes, Repairing.  |
|   | Walking Sticks.  |
|   | Waterproofing.   |

In demy 8vo, cloth, 600 pages and 1,420 illustrations, 6s.

**SPONS'**  
**MECHANICS' OWN BOOK;**  
**A MANUAL FOR HANDICRAFTSMEN AND AMATEURS.**

CONTENTS.

Mechanical Drawing—Casting and Founding in Iron, Brass, Bronze, and other Alloys—Forging and Finishing Iron—Sheetmetal Working—Soldering, Brazing, and Burning—Carpentry and Joinery, embracing descriptions of some 400 Woods, over 200 Illustrations of Tools and their uses, Explanations (with Diagrams) of 116 joints and hinges, and Details of Construction of Workshop appliances, rough furniture, Garden and Yard Erections, and House Building—Cabinet-Making and Veneering—Carving and Fretcutting—Upholstery—Painting, Graining, and Marbling—Staining Furniture, Woods, Floors, and Fittings—Gilding, dead and bright, on various grounds—Polishing Marble, Metals, and Wood—Varnishing—Mechanical movements, illustrating contrivances for transmitting motion—Turning in Wood and Metals—Masonry, embracing Stonework, Brickwork, Terracotta and Concrete—Roofing with Thatch, Tiles, Slates, Felt, Zinc, &c.—Glazing with and without putty, and lead glazing—Plastering and Whitewashing—Paper-hanging—Gas-fitting—Bell-hanging, ordinary and electric Systems—Lighting—Warming—Ventilating—Roads, Pavements, and Bridges—Hedges, Ditches, and Drains—Water Supply and Sanitation—Hints on House Construction suited to new countries.

**E. & F. N. SPON, 125 Strand, London.**  
**New York: 12 Cortlandt Street.**